



Marine air-conditioning and refrigeration solutions since 1971.



## INDEX

HISTORY 4  
SERVICE NETWORK 7

### CLIMMA MARINE AIR-CONDITIONING

#### *Self contained systems*

---

CLIMMA COMPACT 8  
CLIMMA SPLIT 12

#### *Centralized systems*

---

CLIMMA CWS AQUACONTROL 14  
CLIMMA CWS DC INVERTER LINE 16  
CLIMMA CWS SOLO 18  
CLIMMA CWS MODUL 20  
CLIMMA FANCOILS EVA 22  
CLIMMA FANCOILS FC AND FCV 24  
CLIMMA MISTRAL FRESH AIR UNITS 26  
CLIMMA AIR EXTRACTORS 27  
CLIMMA BOILERS 28  
CLIMMA MISTIFIER SYSTEM H2OASI 34

#### *Accessories*

---

CLIMMA AIR ACCESSORIES 29  
CLIMMA SEA WATER ACCESSORIES 32  
CLIMMA FRESH WATER ACCESSORIES 33

### FRIGOBOAT MARINE REFRIGERATION

#### *Frigomatic D.C. refrigeration systems*

---

FRIGOMATIC COMPRESSORS 39  
EVAPORATORS 41  
KEEL COOLERS 43  
ACCESSORIES 43

#### *A.C. refrigeration systems*

---

A.C. REFRIGERATION SYSTEMS 45

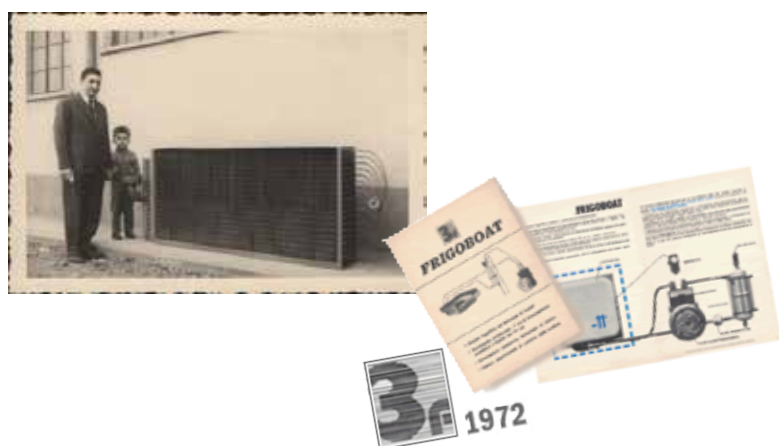
#### *Frigoboat cabinets*

---

FRIGOBOAT MS SERIE 46  
ICE MAKERS 49  
FRIGOBOAT CUSTOM LINE 50  
FRIGOBOAT COLD ROOMS 52

Success comes from the ability to respond to market demands. This concept has been the core of Veco's philosophy since 1971, and it is still the same after more than 40 years of business. This has permitted the founder, Franco Formenti, to evolve an innovative refrigerating system designed in 1970 for a sailor friend, to today's comprehensive range of highly sophisticated refrigeration and air conditioning products.

*Il successo deriva dalla capacità di rispondere alle esigenze del mercato. Questo concetto è il nucleo della filosofia Veco fin dalle origini, nel 1971, permettendo all'Ing. Franco Formenti, fondatore dell'azienda, di passare da un sistema innovativo di frigorifero, realizzato in maniera artigianale nel 1970 per un amico velista, ad una serie di prodotti sempre più sofisticati e diversificati nel campo della refrigerazione e del condizionamento marino.*



**1971**

'3F di F.Formenti' is established by Franco Formenti  
*L'Ing Franco Formenti fonda la '3F di F. Formenti'.*

**1978**

The brand FRIGOBOAT is adopted for marine refrigeration systems, as the name of the company becomes 'FRIGOBOAT s.n.c.'. Franco Formenti's son, Carlo, joined Franco in the company.

*Nasce il marchio FRIGOBOAT per la refrigerazione marina. Nella ditta FRIGOBOAT s.n.c. entra il figlio Carlo.*



**1982**

The company becomes Veco S.p.A. a joint stock company.  
*L'azienda diventa una Società per Azioni, Veco S.p.A.*

**1984**

The brand CLIMMA is adopted for marine air-conditioning systems.  
*Nasce il marchio CLIMMA per impianti per il condizionamento marino.*



**2000**

Veco N.A. was founded, to manage the US market, with a 4500 sm warehouse and currently 72 service centers.

*Viene creata la Veco N.A. per il mercato americano, con un magazzino di 4500 mq e che ora raccoglie circa 72 centri assistenza sul territorio.*

**2014**

Now with the third generation, Veco is a worldwide company pursuing the same goals: innovation and quality.

*Ormai alla terza generazione, l'azienda leader di mercato porta avanti progetti con la stessa passione e qualità che l'hanno caratterizzata fin dal 1971.*

With the brand **CLIMMA** Veco manufactures marine air-conditioning systems, from small independent self-contained units to customized, centralized chiller systems up to 2 million Btu, fancoils, mistifiers, fresh air make-up units, boilers and air extractors.



*Il marchio **CLIMMA** identifica gli impianti di condizionamento marino; da piccoli impianti indipendenti a potenti impianti centralizzati e fancoil, fino ad arrivare a soluzioni chiller completamente personalizzate. La gamma comprende inoltre nebulizzatori, unità di trattamento aria, boiler e estrattori d'aria, per gestire a 360° il comfort a bordo.*



The brand **FRIGOBOAT** covers a wide range of marine refrigeration systems, with DC models suitable up to 400 liters and 230V models, suitable for large cold rooms, standard and custom stainless steel cabinets, wine cellars and completely customized cold rooms.

*Con il marchio **FRIGOBOAT** viene caratterizzata un'ampia gamma di sistemi per la refrigerazione marina, da impianti in corrente continua per celle frigorifere da 50 fino 400 litri ad impianti in corrente alternata per celle frigorifere, mobili frigoriferi in acciaio inox standard e su misura, cantine vino e celle frigorifere calpestabili completamente personalizzabili.*

The company is based in Giussano, Italy, with a 5.000 s.m. area. With state-of-the-art test room, laser cutting machines and robotic work centers, Veco's products perfectly represent the **Made in Italy** concept.

In order to meet the highest standards of quality control, the technical Department includes an R&D branch and a specific department for Quality Management.

Since 1996, Veco has also been certified ISO 9001-2008 by DNV.

In 2018 DNV has confirmed Veco S.p.A. certification towards the new standards **UNI EN ISO 9001:2015**.



*L'azienda si trova a Giussano, nel cuore della Brianza, e occupa una zona di 5.000 metri quadri.*

*Con un innovativo impianto per il collaudo e la verifica di macchine per il condizionamento, un laboratorio per i test, macchine per il taglio laser e un innovativo centro di piegatura robotizzato, Veco è un perfetto esempio del concetto di qualità e di **Made in Italy**.*

*Proprio per mantenere uno standard elevato, all'interno dell'azienda è stato creato un dipartimento che si occupa esclusivamente del controllo qualità.*

*Dal 1996 la VECO è inoltre certificata ISO 9001-2008. Nel 2018 l'ente di certificazione ha confermato per Veco S.p.A. la validità della certificazione adeguandola alla nuova norma **UNI EN ISO 9001:2015**.*

#### QUALITY SERVICE

Veco S.p.A. strongly believes in training, education and in keeping our sales and service centers always updated; therefore in the company plant there is a dedicated area for classes and courses.

Every year Veco S.p.A. organizes training courses, from the theory to the practical, with a dedicated laboratory to test and try products.

#### ASSISTENZA QUALIFICATA

*Veco S.p.A. investe da sempre nella formazione e nell'aggiornamento dei propri centri assistenza e vendita.*

*Ogni anno Veco S.p.A. organizza specifici corsi tecnici per i propri partner, partendo dalla teoria fino ad arrivare alla pratica, svolta in un laboratorio dedicato.*



Veco N.A.

ARGENTINA | AUSTRALIA | AZORES | BAHRAIN | BENELUX | BRASIL  
CANADA | CANARY ISLANDS | CHILE | CHINA | CROATIA | CYPRUS  
DJIBOUTI | EGYPT | ENGLAND | FINLAND | FRANCE | GERMANY | GREECE  
HONG KONG | HUNGARY | INDIA | IRAN | ISRAEL | ITALY | JAPAN | KENYA | KOREA  
KUWAIT | MALTA | MEXICO | MONTENEGRO | MOZAMBIQUE | NEW CALEDONIA  
NEW ZEALAND | OMAN | PANAMA | PHILIPPINES | POLAND | PORTUGAL  
QATAR | RUSSIA | SAUDI ARABIA | SERBIA | SINGAPORE | SLOVENIA  
SOMALIA | SOUTH AFRICA | SPAIN | SRI LANKA | SWEDEN | SWITZERLAND  
TAIWAN | TANZANIA | THAILAND | TUNISIE | TURKEY  
UNITED ARAB EMIRATES | UNITED STATES | YEMEN



Veco S.p.A.

**Veco N.A.**

4831 Tesla Dr # H  
Bowie, MD 20715, United States  
phone +1 301-352-6962  
e-mail [info@veco-na.com](mailto:info@veco-na.com)  
web [www.veco-na.com](http://www.veco-na.com)

**VECO S.p.A.**

via General Cantore, 6  
20833 Giussano, MB, Italy  
phone +39 0362 35321 | fax +39 0362 252995  
e-mail [info@veco.net](mailto:info@veco.net)  
web [www.veco.net](http://www.veco.net)





photo courtesy of Solaris



Compact 3.5

- SELF-CONTAINED INDEPENDENT AIR-CONDITIONING SYSTEMS FROM 3.500 UP TO 24.000 BTU/H
- R410A ECOLOGIC REFRIGERANT ENSURES EFFICIENCY AND LOWER POWER CONSUMPTION
- VERY SLIM HIGH-EFFICIENT HEAT EXCHANGER
- POWERFUL AND ROTATABLE FAN
- BRASS THREADED CONDENSATION OUTLET PIPE AND DRY PAN CLIMMA SYSTEM

- SISTEMI DI CONDIZIONAMENTO INDIPENDENTI DA 3.500 A 24.000 BTU/H
- REFRIGERANTE ECOLOGICO R410A PER UNA MASSIMA EFFICIENZA E CONSUMI RIDOTTI AL MINIMO
- SCAMBIATORE ARIA-GAS AD ALTO RENDIMENTO
- VENTILATORE POTENZIATO E MOVIBILE
- SCARICO CONDENZA FILETTATO IN OTTONE E VASCHETTA ANTI-CONDENZA CON SISTEMA DRY PAN

Climma Compact series of independent air-conditioners are perfect for cooling single or adjacent cabins.

All of the Climma Compact range has been specifically designed for nautical applications, with water cooled condensers, a very compact design, quiet and powerful blowers and an ecologic refrigerant, they are supplied as standard with the reverse cycle option.

All Climma compact units are available in cool only version, or with electrical heating.

*I condizionatori indipendenti Climma Compact, sono perfetti per condizionare un singolo ambiente oppure ambienti contigui.*

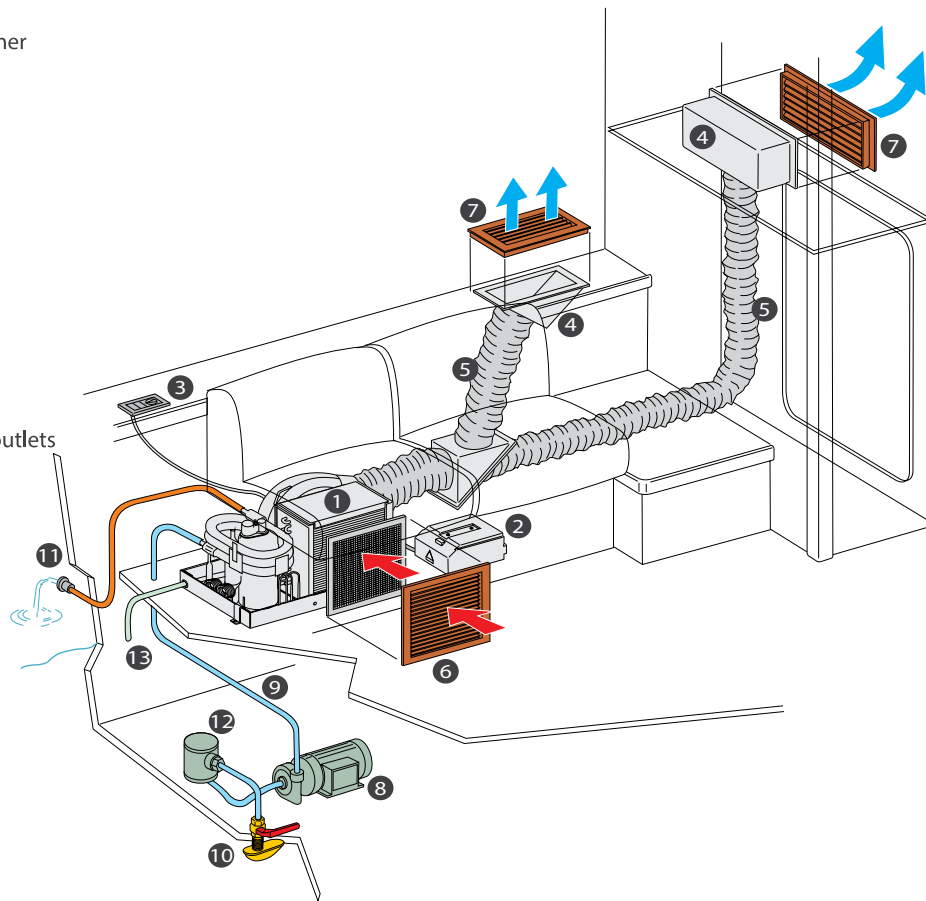
*Studiati appositamente per applicazioni nautiche, tutti i condizionatori della gamma Climma Compact sono raffreddati ad acqua. Compatti, silenziosi e potenti, funzionano con refrigerante ecologico e vengono forniti con l'opzione inversione di ciclo, per poter riscaldare l'ambiente.*

*Disponibili anche in versione solo freddo o con riscaldamento elettrico.*



# COMPLETE CLIMMA INDEPENDENT AIR-CONDITIONING SYSTEM

- 1 Climma Compact air-conditioner
- 2 Climma Compact Control Box
- 3 Climma Control Panel MK3
- 4 Plenums
- 5 Insulated ducts
- 6 Intake air grills
- 7 Delivery air grills
- 8 Sea water pump
- 9 Hoses for the sea water circuit
- 10 Sea water intake
- 11 Sea water exit
- 12 Water filter
- 13 Condensate drain hoses and outlets



## STANDARD DIGITAL PANEL MK3



Code MK3\*

## PANEL MK2 WITH REMOTE CONTROL OPTION



Code MDIS\* (code MTELE for the remote)



## CLIMMA C-TOUCH NEW CONTROL

The new Climma C-TOUCH thermostat has been designed to be easy to use and simple, to get the best out of your climate control. C-TOUCH is compatible with Climma self-contained Compact solutions and Climma fancoils, and allows for a weekly scheduler, customizable interfaces and colors and it's designed for the most common Vimar and BTicino cover plates.

*Il nuovo termostato Climma C-TOUCH, studiato per essere semplice ed intuitivo, permette un controllo a 360° del comfort a bordo. Compatibile con tutti gli impianti Climma, sia Compact che fancoil, permette la programmazione settimanale, la personalizzazione delle interfacce anche per colore ed è compatibile con le più comuni placche Vimar e BTicino.*



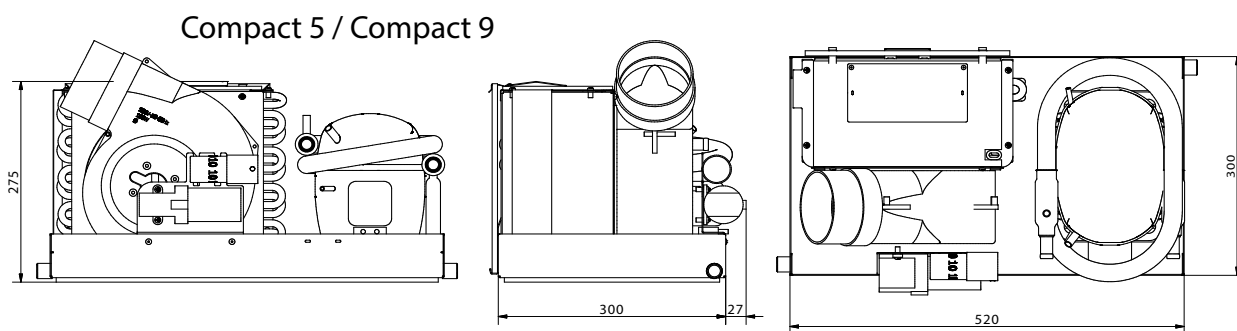
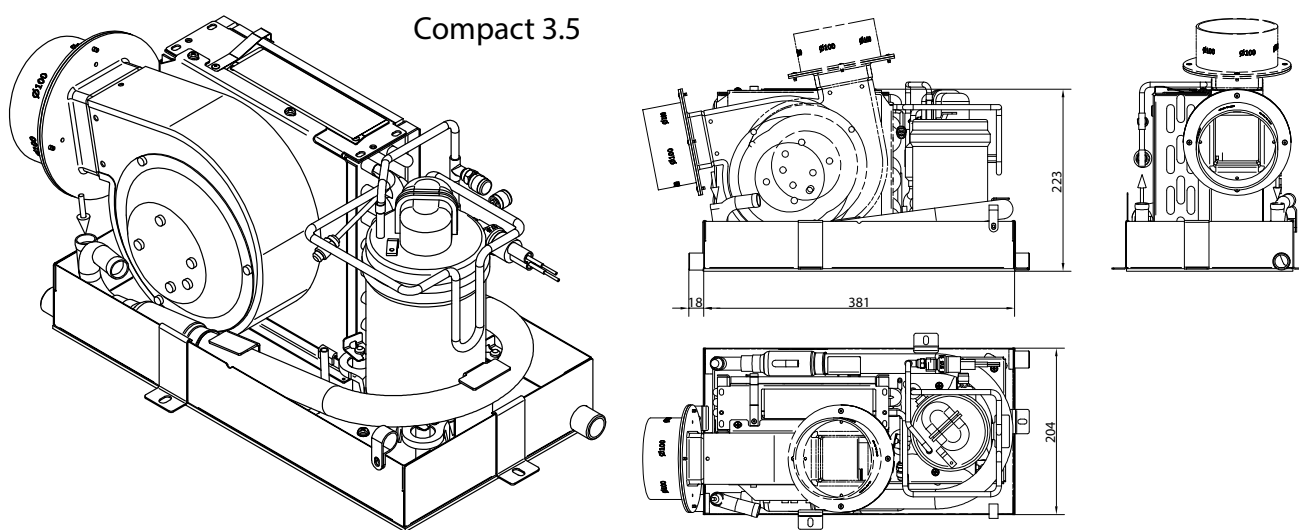
Code MPACT\*

		Compact 3.5	Compact 5	Compact 7	Compact 9	Compact 12	Compact 16	Compact 17 S	Compact 24
230/1/50	EH - electrical heating	-	MCN5K3EHU	MC7EFEHU	MCN9K3EHU	MC12EFEHU	MC16EFEHU	MCN17SK3BEHU	MC24SEFEHU
	RC - reverse cycle (heat pump)	MC35K3RCU	MCN5K3RCU	MC7EFRCU	MCN9K3RCU	MC12EFRCU	MC16EFRCU	MCN17SK3BRCU	MC24SEFRCU
	CO - cool only	MC35K3COU	MCN5K3COU	MC7EFCOU	MCN9K3COU	MC12EFCOU	MC16EFCOU	MCN17SK3BRCU	MC24SEFCOU
230/1/60	RC - reverse cycle (heat pump)	-	-	MC7EFRCW	-	MC12EFRCW	MCN16K3RCW	-	MC24SEFCW
	CO - cool only	-	-	MCN7K3BCOW	-	MCN12K3BCOW	MCN16K3COW	-	MC24SEFCOW
115/1/60	RC - reverse cycle (heat pump)	MC42K3RCI	-	MCN7K3RCI	-	MCN12K3BRCI	MCN16K3RCI	-	-
	CO - cool only	MC42K3COI	-	-	-	MCN12EFCOI	MCN16K3COI	-	-

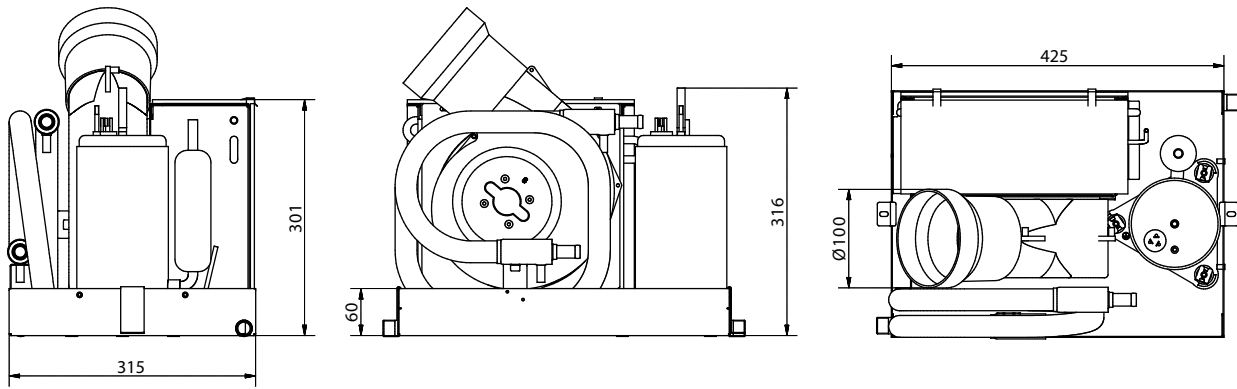
	Compact 3.5	Compact 5	Compact 7	Compact 9	Compact 12	Compact 16	Compact 17	Compact 24
Capacity Cool - Capacità in freddo (Btu/h)	3.500	5.000	7.000	9.000	12.000	16.000	17.000	24.000
Capacity Heat - Capacità in caldo (Btu/h)	3.500	4.500	7.000	9.000	12.000	16.000	17.000	24.000
Net Weight - Peso Netto (Kg)	12	25	26	26	31,5	40	42	45
Shipping Weight - Peso Lordo (Kg)	15	30	31	31	36,5	46	48	55
Duct Size - Dimensione condotta (mm)	100	100	100	100	125	150	2x100	2x125
Air Flow - Massimo flusso d'aria (m <sup>3</sup> /h)	230	230	230	230	530	900	600	2x540
Size - Dimensioni (WxDxH for 230/1/50)	381x204x227	520x300x295	425x315x316	520x300x295	523x330x340	605x368x352	800x398x330	800x398x415
Electrical heating for EH models only (W)	N.A.	1300	1300	1300	1600	2000	1300x2	1300x2

Power supply	Compact 3.5	Compact 5	Compact 7	Compact 9	Compact 12	Compact 16	Compact 17	Compact 24
230/1/50 Power Supply	Available	Available	Available	Available	Available	Available	Available	Available
230/1/60 Power Supply	-	-	Available	-	Available	Available	-	Available
115/1/60 Power Supply	Available	-	Available	-	Available	Available	-	-
400/3/50 Power Supply	-	-	-	-	-	-	-	-

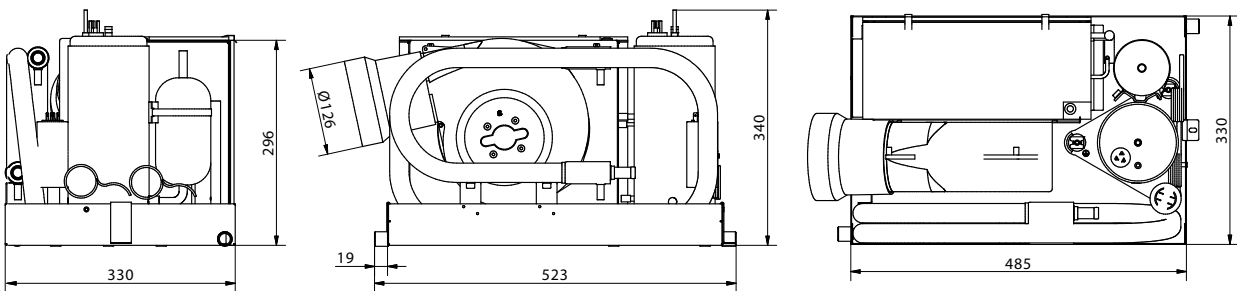
Refrigerant Type	Compact 3.5	Compact 5	Compact 7	Compact 9	Compact 12	Compact 16	Compact 17	Compact 24
230/1/50 Power Supply	R134A	R134A	R410a	R134A	R410a	R410a	R407C	R410a
230/1/60 Power Supply	-	-	R417C	-	R410a	R417C	-	R410a
115/1/60 Power Supply	R134A	-	R417C	-	R417C	R417C	-	-
400/3/50 Power Supply	-	-	-	-	-	-	-	-



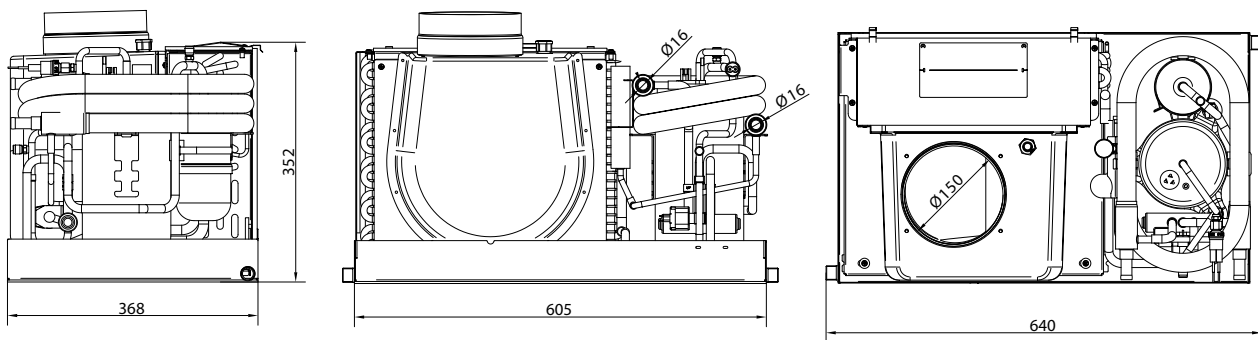
### Compact 7



### Compact 12



### Compact 16



### Compact 17 / Compact 24

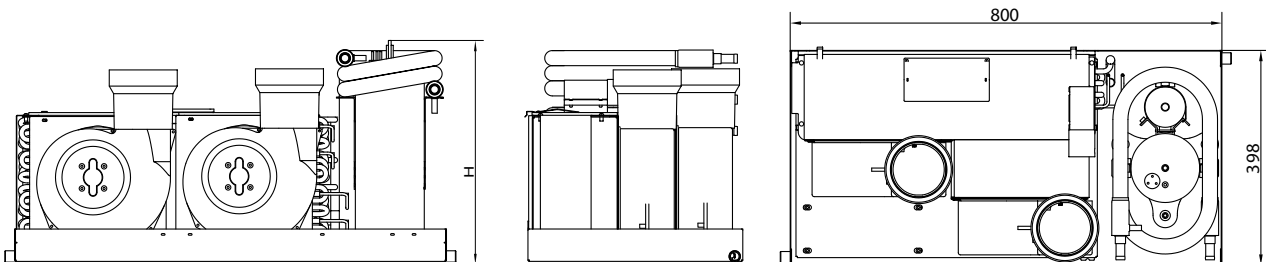




photo courtesy of Solaris

- SELF-CONTAINED INDEPENDENT AIR-CONDITIONING SPLIT SYSTEMS FROM 8.000 UP TO 24.000 BTU/H
  - R410A ECOLOGIC REFRIGERANT ENSURES EFFICIENCY AND LOWER POWER CONSUMPTION
  - VERY SLIM HIGH-EFFICIENT HEAT EXCHANGER
  - POWERFUL AND ROTATABLE FAN
  - BRASS THREADED CONDENSATION OUTLET PIPE AND DRY PAN CLIMMA SYSTEM
- *SISTEMI DI CONDIZIONAMENTO INDIPENDENTI A SPLIT DA 8.000 A 24.000 BTU/H*
  - *REFRIGERANTE ECOLOGICO R410A PER UNA MASSIMA EFFICIENZA E CONSUMI RIDOTTI AL MINIMO*
  - *SCAMBIATORE ARIA-GAS FINE AD ALTO RENDIMENTO*
  - *VENTILATORE POTENZIATO E MOVIBILE*
  - *SCARICO CONDENSA FILETTATO IN OTTONE E VASCHETTA ANTI-CONDENSA CON SISTEMA DRY PAN*

STANDARD DIGITAL PANEL MK3



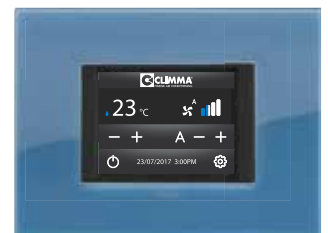
Code MK3\*

PANEL MK2 WITH REMOTE CONTROL OPTION



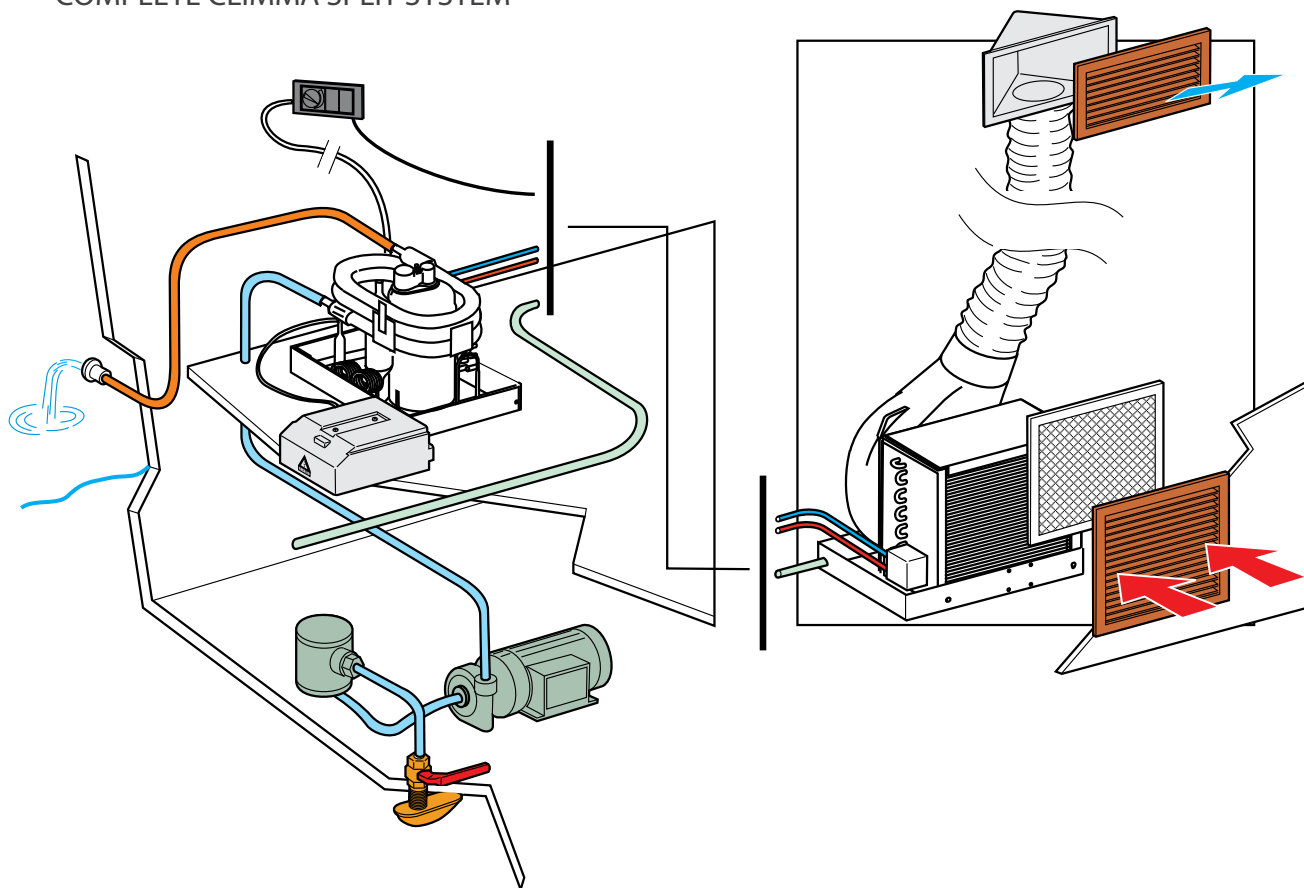
Code MDIS\* - Code MTELE

CLIMMA NEW C-TOUCH CONTROL



Code MPACT\*

# COMPLETE CLIMMA SPLIT SYSTEM



	SPLIT 8	SPLIT 12	SPLIT 16	SPLIT 17	SPLIT 24
Capacità nominale in freddo Nominal capacity cool (Btu/h)	<b>8.000</b>	<b>12.000</b>	<b>16.000</b>	<b>17.000</b>	<b>22.000</b>
Capacità nominale in caldo Nominal capacity heat (Btu/h)	8.000	12.000	16.000	17.000	22.000
Consumo in freddo – Consumption cool mode (A)	3,40	4,07		6,50	-
Consumo in caldo – Consumption heat mode (A)	3,40	4,55		-	-
Corrente di start – Start amperage draw (A)	21,80	23,60		-	-
Peso netto – Net Weight (Kg/lbs)	26 / 57	32 / 70	41 / 90	42 / 93	49 / 108
Peso spedizione – Shipping weight (Kg/lbs)	31 / 68	37 / 82	47 / 104	48 / 106	55 / 121
Fitting - pipe suction line	pre-charged pipes with self couplings	3/8 SAE Flare 10 mm	1/2 Flare 12 mm	1/2 Flare 12 mm	1/2 Flare 12 mm
Fitting - pipe liquid line	pre-charged pipes with self couplings	1/4SAE Flare 6 mm	3/8 Flare 10 mm	3/8 Flare 10 mm	3/8 Flare 10 mm
Volume con imballo – Shipping volume (cu.M)	-	0,60		1,00	-
Dimensione condotta – Duct size (mm/in)	100mm / 4in	125mm / 5in	2x100mm / 4in	2x100mm / 4in	2x125mm / 5in

		Btu/h	EH*	RC*
<b>SPLIT 8 MK3</b>	COMPRESSORE / COMPRESSOR	8.000	MSN8K3EHU	MSN8K3ECU
	EVAPORATORE / EVAPORATOR	8.000	MESA8K3EHU	MESA8K3RCU
<b>SPLIT 12 EF</b>	COMPRESSORE / COMPRESSOR	12.000	MS12EFEHU	MS12EFRUCU
	EVAPORATORE / EVAPORATOR	12.000	MESA12EFEHU	MESA12EFRUCU
<b>SPLIT 16 EF</b>	COMPRESSORE / COMPRESSOR	16.000	MS16EFEHU	MS16EFRUCU
	EVAPORATORE / EVAPORATOR	16.000	MESA16EFEHU	MESA16EFRUCU
<b>SPLIT 17 MK3</b>	COMPRESSORE / COMPRESSOR	17.000	MSN17SK3EHU	MSN17SK3RCU
	EVAPORATORE / EVAPORATOR	17.000	MESA17SK3EHU	MESA17SK3RCU
<b>SPLIT 24 MK3</b>	COMPRESSORE / COMPRESSOR	24.000	MSN24SK3EHU	MS24SK3RCU
	EVAPORATORE / EVAPORATOR	24.000	MES24SK3EHU	MESA24SK3RCU





photo courtesy of Uniesse



- COMPACT, EASY TO INSTALL, EASY TO MAINTAIN
- FROM 16.000 TO 48.000 BTU/H
- SILENT: ANTI-VIBRATION MOUNTING SYSTEM AS STANDARD
- ELEGANT STAINLESS STEEL FRAME WITH CONDENSATE TRAY FOR DRAIN
- REVERSE CYCLE OR COOL ONLY OPTIONS AVAILABLE

- COMPATTO, FACILE DA INSTALLARE E DA GESTIRE
- DISPONIBILE DA 16.000 FINO A 48.000 BTU/H
- SILENZIOSO: SISTEMA CON ANTIVIBRANTI MONTATI COME STANDARD
- ELEGANTE STRUTTURA IN ACCIAIO INOX CON VASCA ANTICONDENSA
- DISPONIBILE IN INVERSIONE DI CICLO COME STANDARD O SOLO FREDDO



The new chiller AQUACONTROL is the most reliable, efficient and quiet CWS available. A major step forward in design and performance, the result of Climma's 25 years' experience and knowledge in the manufacture of marine air conditioning systems.

The compact design allows us to provide the largest capacity of cooling from the smallest foot print yet.

This is achieved by using the latest rotary compressors available (requiring 25% lower start current than previous models) combined with large capacity cupronickel sea water condensers for more effective cooling.

Noise and vibration is minimised through Climma's anti-vibration mounts and damper system.

Available in 5 sizes from 12.000 to 48.000 BTU/h capacity reverse cycle as standard or cool only on request.

The AQUACONTROL chillers can be easily configured into multiple systems to provide greater cooling capacity, or integrated in a domotic system, thanks to the built in RS585 interface.

Fit the Aquacontrol with Climma's latest EVA fan coils to achieve the ultimate in comfort and climate control on-board.

*La nuova linea CWS AQUACONTROL, sviluppata da Climma per soddisfare le più strette esigenze del mercato nautico, comprende un'ampia gamma di chiller affidabili, efficienti e silenziosi.*

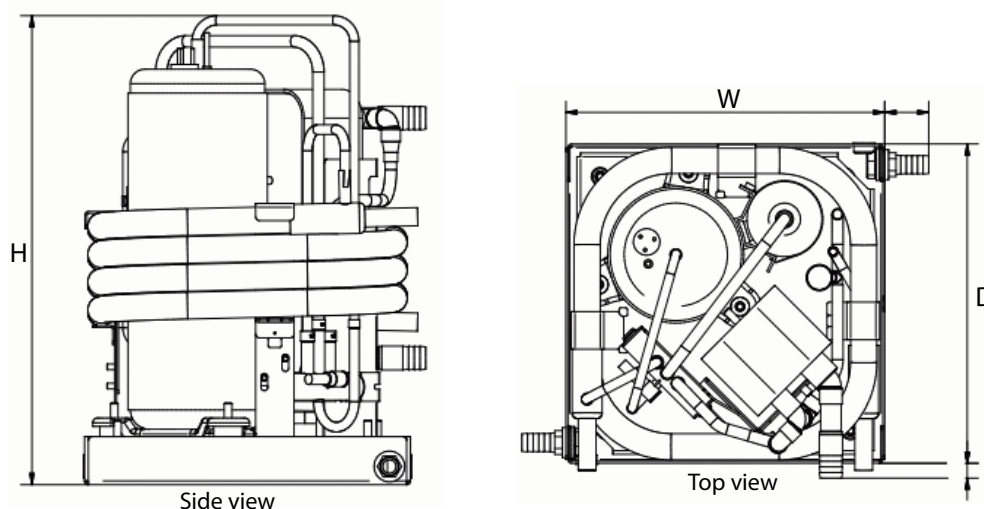
*Affidabilità garantita da un marchio con più di 35 anni. Compressori di ultima generazione e condensatori in cupronickel ad alta efficienza permettono di ottenere un design estremamente compatto mantenendo capacità elevate, garantendo inoltre un rendimento migliore rispetto a macchine tradizionali (-25% di corrente di spunto).*

*Il sistema anti-vibrante montato direttamente su struttura in acciaio inox permette di ridurre al minimo rumori e vibrazioni.*

*I chiller CWS AQUACONTROL sono disponibili in 5 misure da 12.000 fino a 48.000 BTU/h, in versione standard con inversione di ciclo o in versione solo freddo.*

*Tutti i modelli sono facilmente integrabili in sistemi multipli e con sistemi di domotica (tramite l'interfaccia integrata RS485).*

*La combinazione del chiller CWS AQUACONTROL con i fancoil Climma EVA permette un controllo ottimale del confort a bordo.*



Model	Veco code	Nominal Capacity (Bth/hr)	Power Supply	Ampere Run cool (A)	Ampere Run heat (A)	Start current (A)	Net weight (Kg)	Shipping weight (Kg)	Size WxDxH (mm)	Electrical Box WxDxH (mm)
CWS 161	MEF161RCU	16.000	230/1/50	6,2	7,4	32,0	36	40	340x340x404	243x208x60
	MEF161RCW	16.000	230/1/60	5,4	6,8	-	36	40	340x340x404	243x208x60
CWS 201	MEF201RCU	20.000	230/1/50	6,9	8,6	37,0	39	44	340x340x404	243x208x60
	MEF201RCW	20.000	230/1/60	7,4	9,8	-	39	44	340x340x408	243x208x60
CWS 251	MEF251RCU	25.000	230/1/50	9,8	11,1	61,0	43	47	340x340x496	243x208x60
	MEF251RCW	25.000	230/1/60	7,4	9,3	-	43	47	340x340x496	243x208x60
CWS 301	MEF301RCU	30.000	230/1/50	10,3	12,5	63,0	-	-	340x340x496	243x208x60
CWS 481	MEF481RCU	48.000	230/1/50	11,5	14,8	116,8	-	-	410x420x534	243x208x60
	MEF481RCY	48.000	400/3/50	5,2	6,1	66,0	-	-	410x420x534	300x220x120



## CWS DC

- ✓ Variable power from a single air-conditioning system
  - ✓ **Water cooled inverter**
  - ✓ Climma control delivers **modulated power**
  - ✓ **ECO mode**
  - ✓ **No start load**
  - ✓ Up to **50% energy saving**
- 
- ✓ **Potenza variabile** con un singolo condizionatore
  - ✓ **Inverter raffreddato ad acqua**
  - ✓ Controllo per **modulare la potenza**
  - ✓ **Funzione ECO**
  - ✓ **Corrente di spunto azzerata**
  - ✓ Fino al **50% di risparmio**

The new Climma DC Inverter chiller is the result of careful design and innovation based on over 40 years manufacturing experience to optimise the energy efficiency of marine air-conditioning chillers. Climma's DC chiller is driven by their unique water cooled inverter lowering the power requirement by up to 50% compared to traditional chillers.

### Variable Output from a Single Unit

Climma's new DC chiller is programmed to run at the optimum speed; depending on the heat load requirements, the compressor frequency varies controlling the output capacity from 0% up to 100% of the unit power.

### Unique Water Cooled Inverter

Unique in the marine industry, Climma's water cooled inverter protects the compressor from excessive temperature and irregular voltage supply, allowing it to be installed in the engine room without additional ventilation.

### Climma Intelligent Control

Heating and cooling capacity is managed by the Climma Intelligent Control unit (CIC) which uses specially configured algorithms to ensure maximum efficiency.

### ECO mode

Climma DC chillers provide further efficiency gain through a special ECO mode. ECO mode enables the chiller to work when only a courtesy/night generator is working or even while on the dock with a limited shore power supply.

### No Start Load

Climma DC chiller requires no additional amps to start the compressor.

*La nuova linea di condizionatori Climma DC brushless è il risultato della continua ricerca Veco volta ad ottimizzare i consumi dei chiller a bordo. Grazie all'innovativa tecnologia ad inverter i nuovi chiller Climma DC migliorano i consumi fino al 50% rispetto ai chiller tradizionali, permettendo inoltre un ottimo e preciso controllo del raffreddamento e riscaldamento a bordo.*

### Potenza variabile in un singolo chiller

*I nuovi chiller Climma DC Inverter garantiscono sempre la velocità ottimale rispetto alla richiesta a bordo. A seconda del carico si modifica automaticamente la potenza del sistema da 0% fino al 100% della potenza della macchina.*

### Inverter raffreddato ad acqua

*Primi nell'industria nautica, gli inverter Climma con raffreddamento ad acqua proteggono e controllano il compressore, permettendo un'installazione in sala macchine senza ventilazione aggiuntiva.*

### Controllo Climma

*Raffreddamento e riscaldamento sono controllati dall'innovativo controllo Climma che tramite un algoritmo appositamente studiato garantisce sempre la massima efficienza.*

### Funzione ECO

*Tutta la nuova linea Climma DC è stata studiata con la funzione speciale ECO per ridurre i consumi a bordo. La funzione ECO permette il funzionamento anche con un generatore ridotto o durante la notte, quando non è richiesto il massimo della potenza.*

### Corrente di spunto azzerata

*Grazie all'innovativa tecnologia ad inverter, i nuovi chiller Climma DC Inverter non hanno corrente di spunto.*



	DC35	DC50	DC65	DC130
<b>POWER SUPPLY</b>	230V/1/50-60Hz	230V/1/50-60Hz ( or 400V/3/50-60Hz + N)	230V/1/50-60Hz ( or 400V/3/50-60Hz + N)	400V/3/50-60Hz + N
<b>CAPACITY (COOL MODE)</b>	<b>2,5 - 120 kW</b> (8k - 35k Btu)	<b>3 - 14 kW</b> (10k - 50k Btu)	<b>3,5kW - 19kW</b> (12k - 65k Btu)	<b>10kW - 38kW</b> (35k - 130k Btu)
<b>CAPACITY (HEAT MODE)</b>	<b>2,5 - 120 kW</b> (8k - 35k Btu)	<b>4 kW - 16 kW</b> (13k - 55k Btu)	<b>5kW - 20,5kW</b> (17k - 70k Btu)	<b>10kW - 38kW</b> (35k - 130k Btu)
<b>POWER CONSUMPTION (A) - COOL MODE</b>	0 A - 9,5 A	0 A - 18 A	0 A - 23 A	0 A - 12,5 A
<b>POWER CONSUMPTION (kW) - COOL MODE</b>	0 kW - 2,2 kW	0 kW - 4 kW	0 kW - 5,2kW	0 kW - 13 kW
<b>START CURRENT (A)</b>	0 A	0 A	0 A	0 A
<b>REFRIGERANT AND CHARGE</b>	R410a	R410a (1180 gr)	R410a (1341 gr)	R410a (1990 gr)
<b>FRESH WATER FLOW (m3/h)</b>	1,8 m3/h	2 m3/h	3 m3/h	6,5 m3/h
<b>SEA WATER FLOW (m3/h)</b>	1,8 m3/h	2 m3/h	3 m3/h	6,5 m3/h
<b>SEA WATER TEMP. (HEAT MODE)</b>	> 5 °C	> 5 °C	> 5 °C	> 5 °C
<b>SEA WATER TEMP. (COOL MODE)</b>	< 38 °C	< 38 °C	< 38 °C	< 38 °C
<b>SIZE (LxDxH in mm)</b>	335 x 342 x 472	420 x 375 x 453	500 x 425 x 454	415 x 650 x 630
<b>ELECTRICAL BOX (LxDxH in mm)</b>	240X190X90	240X190X90	240X190X90	included in size
<b>WEIGHT (Kg)</b>	n.a.	50	55	n.a.

NOW AVAILABLE AS MULTI COMPRESSOR SYSTEM, UP TO 520,000 BTU  
 ORA DISPONIBILE COME SISTEMA MULTICOMPRESSORE FINO A 520,000 BTU

CHILLER  
POWER



20%



40%



100%

Operating on a sunny day, when the heat load request is high, the system will run at full speed; while at night, when the heat load is lower, the inverter technology will automatically regulate the compressor to run at the minimum requested speed.

In una giornata soleggiata, quando la richiesta all'impianto di condizionamento è alta, la tecnologia ad inverter permetterà di utilizzare tutta la capacità, mentre durante la notte, quando il carico è basso, il sistema si regolerà per andare alla velocità minima.





photo courtesy of Azimut-Benetti



- FROM 60.000 TO 144.000 BTU/H WITH A SINGLE COMPRESSOR
- STANDARD VERSION IN REVERSE CYCLE
- INVERTER DRIVER COMPLETELY REMOVES START LOAD AND INCREASES EFFICIENCY BY 30%
- HIGHEST CAPACITY FROM THE SMALLEST SIZE
- CUPRONICKEL CONDENSER FOR THE BEST HEAT TRANSFER AND TO IMPROVE RELIABILITY
- INNOVATIVE CLIMMA ANTI-VIBRATION SYSTEM

- DA 60.000 FINO A 144.000 BTU/H A SINGOLO COMPRESSORE
- VERSIONE STANDARD GIÀ CON INVERSIONE DI CICLO
- INVERTER PER ELIMINARE LA CORRENTE DI SPUNTO E RIDURRE I CONSUMI FINO AL 30%
- MASSIME PERFORMANCE IN UNO SPAZIO MINIMO
- CONDENSATORE IN CUPRONICKEL PER IL MASSIMO SCAMBIO TERMICO E LA MIGLIOR AFFIDABILITÀ
- INNOVATIVO SISTEMA CLIMMA ANTI VIBRAZIONI

### Power

Climma CWS SOLO, a powerful system especially designed for yachts to ensure the perfect condition on board. Available from 60.000 up to 144.000 BTU/h with a single compressor, reverse cycle as default and cool only on demand, CWS SOLO is the best solution for yachts from 55 feet up to 30 meters.

### Compact

At VECO we know how much space is an issue; that's why our design is always focused on fitting powerful systems in the smallest size possible. Climma CWS SOLO systems have been designed to be the most compact solution available.

### Quality

Climma's unique control system monitors and checks all the key parameters of the CWS SOLO, maximizing the performance and reliability of the system.

Both the sea water condenser, the sea water circuit and manifolds are made in marine-grade cupronickel for maximum resistance to sea water corrosion.

### Efficiency

All CWS SOLOs are also available with inverter drivers. Climma's unique water cooled inverters completely remove the start current and reduce the power consumption by up to 30%.

### Potenza

Gli impianti chiller Climma CWS SOLO sono la soluzione perfetta per ottenere il massimo confort a bordo.

Disponibili da 60.000 fino a 144.000 BTU/h con un singolo compressore, in inversione di ciclo o in versione solo freddo, si adattano perfettamente a soluzioni per yacht da 55 piedi fino a 30 metri.

### Minimo ingombro

VECO conosce quanto sono importanti gli spazi a bordo. Il design unico di Climma CWS SOLO è studiato per ottenere le massime performance nel minimo spazio possibile, posizionandosi come il più compatto chiller nella sua categoria.

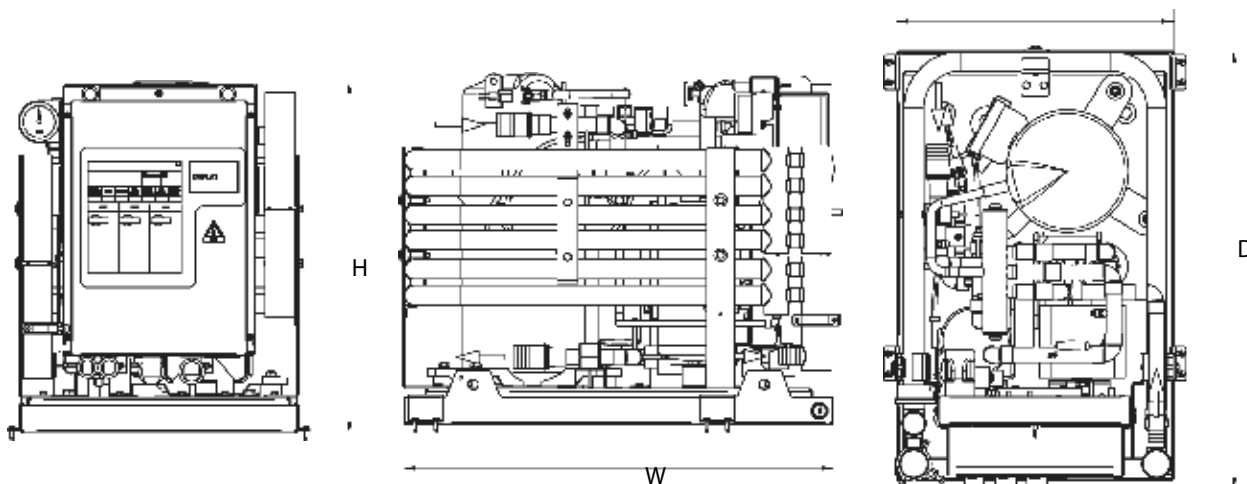
### Qualità

Grazie al sistema di controllo Climma, vengono monitorati tutti i parametri di sistema, massimizzando così le performance e l'affidabilità globale.

Il condensatore, il circuito acqua mare e i relativi collettori sono tutti in cupronickel marino per massimizzare la resistenza alla corrosione.

### Efficienza

Tutti gli impianti CWS SOLO possono essere forniti con lo speciale Inverter Climma raffreddato ad acqua, eliminando così completamente la corrente di spunto e riducendo i consumi fino al 30%.



	Code	Power Supply	Cool mode capacity (Bth/hr)	Cool mode Ampere Run (A)	Heat mode Capacity (Bth/hr)	Heat mode Ampere Run (A)	Start Current (A)*	Fresh water (l/min)	Sea water (l/min)	Net Weight (Kg)	Size HxWxD (mm)
601	MEF601RCUD	230/1/50-602	60.000	43	75.000	21	53 - 0*	50	50	78	506x400x620
	MEF601RCVD	220/3/50		15		18	0*				
	MEF601RCYD	400/3/50		79			153 - 0*				
721	MEF721RCUD	230/1/50-603	72.000	44	90.000	11	53 - 0*	60	60	88	506x400x620
	MEF721RCVD	220/3/60		17		20	0*				
	MEF721RCYD	400/3/50		91		17	3 - 0*				
961	MEF961RCUD	230/1/50-604	96.000	15	120.000	18	7 - 0*	80	80	140	616x400x620
	MEF961RCVD	230/3/50		19		23	152 - 0*				
	MEF961RCYD	400/3/50		91		18	0 - 0*				
1201	MEF1201RCVD	230/3/50	120.000	24	150.000	29	240 - 0*	100	100	160	625x480x750
	MEF1201RCYD	400/3/50		11		13	96 - 0*				
1441	MEF1441RCVD	230/3/50	144.000	26	180.000	32	126 - 0*	120	120	160	625x480x750
	MEF1441RCYD	400/3/50		12		15	96 - 0*				

### CLIMMA WATER COOLED INVERTER

- NO START CURRENT
- REDUCED POWER CONSUMPTION UP TO 30% THANKS TO COMPRESSOR FREQUENCY MODULATION SYSTEM
- EXTREMELY REDUCED SIZE AND MORE EFFICIENCY EVEN WHEN INSTALLED IN ENGINE ROOMS



photo courtesy of Azimut-Benetti

- FROM 60.000 UP TO 1.152.000 BTU/H
- REVERSE CYCLE AS STANDARD
- INVERTER COMPLETELY REMOVES START CURRENT AND IMPROVES EFFICIENCY BY 30%
- HIGHEST CAPACITY FROM THE SMALLEST SIZE
- REDUNDANCY AND RELIABILITY WITH MODULAR DESIGN

- DA 60.000 FINO A 1.152.000 BTU/H
- IN INVERSIONE DI CICLO DI STANDARD
- INVERTER PER ELIMINARE LA CORRENTE DI SPUNTO E RIDURRE I CONSUMI FINO AL 30%
- MASSIME PERFORMANCE IN UNO SPAZIO MINIMO
- RIDONDANZA E L'AFFIDABILITÀ GRAZIE ALLA MODULARITÀ

### Compact and powerful

Climma' CWS MODUL systems are the perfect solution for air-conditioning on yachts from 60 footers to super yachts of 50 meters and up.

A modular system built in stainless steel framed housings incorporating the condensers and manifolds ensuring the Climma CWS is the most compact solution available.

### Efficient and reliable

Climma's unique microprocessor control monitors all the key parameters of the system using Modbus interface protocol to maximize the performance and reliability of the system. All CWS MODULs are also available with inverter drivers. Climma's unique water cooled inverters completely remove the start current and reduce the power consumption of the CWS units by up to 30%.

### Built to the highest quality

Both the sea water condensers, sea water circuits and manifolds are made in marine-grade cupronickel for maximum resistance to sea water corrosion.

Modularity means that Climma CWS MODUL is extremely reliable with redundancy built in to the design. Each compressor is completely independent and can be bypassed from the system, leaving the rest of the system working perfectly. Equally, if necessary, additional modules can be added to an existing system to increase its cooling capacity.

Each single module as well as the overall system is accurately tested as per the highest quality control standards.

### A tailored specification to suit

Available from 60.000 up to 2 million BTU/h, the modular design ensures each system is optimized to the yacht's exact size providing the highest BTU/h from the smallest space.

The frames can be painted, insulated or joined together to form racks. It is also possible to change the sea water circuit positions.

### Potenza in spazi minimi

*Gli impianti chiller Climma CWS MODUL sono la soluzione perfetta per yacht di 60 piedi fino a imbarcazioni di 50 metri o più. Un sistema modulare costruito in un telaio in acciaio inox che incorpora tutti gli elementi del sistema, dal condensatore alle condotte per i circuiti acqua mare e acqua dolce, confermandosi il sistema più compatto per questa categoria.*

### Efficienza e affidabilità

*Grazie all'innovativo sistema di controllo a microprocessore centralizzato Climma, vengono monitorati tutti i parametri di sistema con l'interfaccia Modbus, massimizzando così le performance e l'affidabilità globale.*

*Tutti gli impianti CWS MODUL possono essere forniti con lo speciale Inverter Climma raffreddato ad acqua, eliminando così la corrente di spunto e riducendo i consumi fino al 30%.*

### Qualità garantita dall'esperienza

*Il condensatore, il circuito per l'acqua di mare collegato e i relativi collettori sono tutti costruiti in cupronickel per massimizzare la resistenza alla corrosione dell'acqua di mare.*

*La modularità dei sistemi Climma CWS MODUL garantisce una ridondanza intrinseca. Ogni compressore è completamente indipendente e può essere escluso dal sistema lasciando la macchina perfettamente funzionante. La modularità del sistema permette inoltre di ottenere potenze maggiori semplicemente aggiungendo moduli.*

*Ogni singolo modulo e il sistema completo vengono accuratamente collaudati nel rispetto dei nostri alti standard di qualità.*

### Un sistema fatto su misura

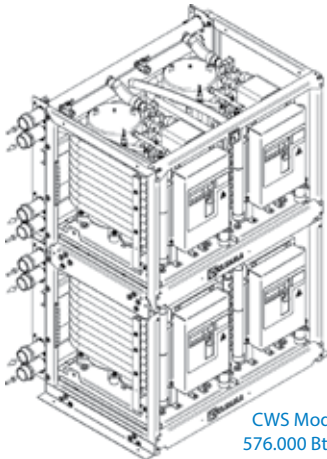
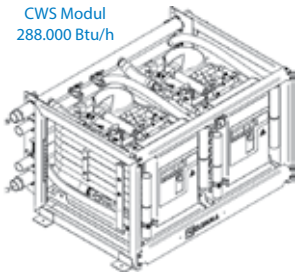
*Disponibili da 60.000 a 2 milioni di BTU/h, i sistemi chiller CLIMMA CWS MODUL permettono ingombri minimi raggiungendo le massime BTU/h nel minimo spazio possibile.*

*La struttura del sistema può essere colorata, isolata o composta per formare rack. E' inoltre possibile cambiare la posizione del circuito dell'acqua mare.*

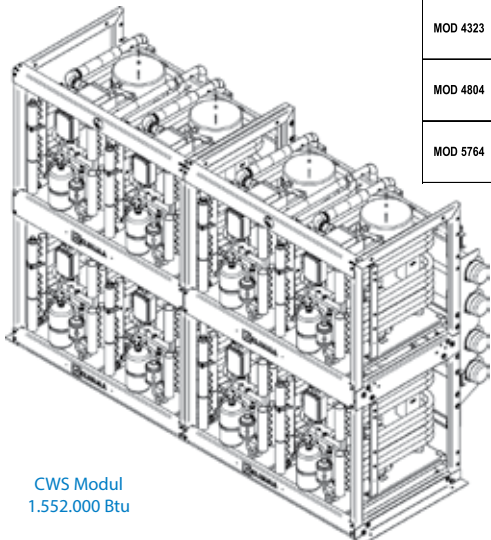




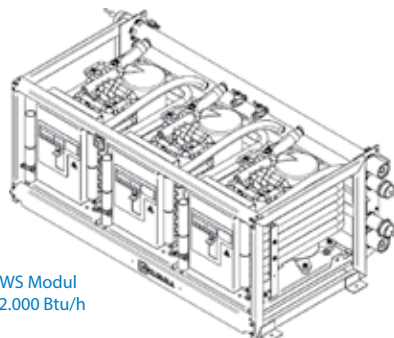
CWS Modul  
288.000 Btu/h



CWS Modul  
576.000 Btu/h



CWS Modul  
1.552.000 Btu



CWS Modul  
432.000 Btu/h

Product	Code	Inverter	Nominal Capacity (Btuh)		Compr. Nr.	Size ** (W1 x D1 x H)	Size *** (W2 x D2 x H)	* Net Weight (Kg)	Power Supply	Amperes Run (A)		Start Current (A)
			Cool	Heat						Cool	Heat	
MOD 1202	MEF1202RCUD	Yes	120.000	150.000	2	950 x 634 x 584	1050 x 718 x 584	211	230/1/50-60	52	62	0
	MEF1202RCVD	Yes							230/3/50-60	24	31	0
	MEF1202RCYD	Yes							400/3/50-60	13	17	0
	MEF1202RCY	No							400/3/50	13	17	55
MOD 1442	MEF1442RCUD	Yes	144.000	180.000	2	950 x 634 x 584	1050 x 718 x 584	231	230/1/50-60	56	68	0
	MEF1442RCVD	Yes							230/3/50-60	27	35	0
	MEF1442RCYD	Yes							400/3/50-60	15	19	0
	MEF1442RCY	No							400/3/50	15	19	74
MOD 1803	MEF1803RCUD	Yes	180.000	200.000	3	1375 x 634 x 584	1472 x 731 x 584	320	230/1/50-60	78	94	0
	MEF1803RCVD	Yes							230/3/50-60	36	47	0
	MEF1803RCYD	Yes							400/3/50-60	20	26	0
	MEF1803RCY	No							400/3/50	20	26	82
MOD 1922	MEF1922RCUD	Yes	192.000	240.000	2	950 x 634 x 704	1050 x 793 x 704	338	230/1/50-60	80	96	0
	MEF1922RCVD	Yes							230/3/50-60	39	46	0
	MEF1922RCYD	Yes							400/3/50-60	21	25	0
	MEF1922RCY	No							400/3/50	21	25	91
MOD 2163	MEF2163RCVD	Yes	216.000	270.000	3	1372 x 634 x 584	1472 x 731 x 584	334	230/3/50-60			0
	MEF2163RCYD	Yes							400/3/50-60			0
	MEF2163RCY	No							400/3/50	23	29	81
MOD 2402	MEF2402RCVD	Yes	240.000	300.000	2	1110 x 768 x 704	1210 x 887 x 704	385	230/3/50-60	46	56	0
	MEF2402RCYD	Yes							400/3/50-60	26	31	0
	MEF2402RCY	No							400/3/50	26	31	109
MOD 2404	MEF2404RCYD	Yes	240.000	300.000	4	2384 x 768 x 704	2400 x 887 x 704	401	400/3/50-60	26	34	0
	MEF2404RCY	No							400/3/50	26	34	68
MOD 2882	MEF2882RCYD	Yes	288.000	360.000	2	1110 x 768 x 704	1210 x 887 x 704	385	400/3/50-60	30	36	0
	MEF2882RCY	No							400/3/50	30	36	111
MOD 2883	MEF2883RCVD	Yes	288.000	360.000	3	1372 x 727 x 700	1472 x 789 x 700	493	230/3/50-60	58	69	0
	MEF2883RCYD	Yes							400/3/50-60	32	38	0
	MEF2883RCY	No							400/3/50	32	38	101
MOD 2884	MEF2884RCVD	Yes	288.000	360.000	4	1900 x 727 x 580	2000 x 786 x 580	441	230/3/50-60	54	70	0
	MEF2884RCYD	Yes							400/3/50-60	30	38	0
	MEF2884RCY	No							400/3/50	30	38	89
MOD 3603	MEF3603RCVD	Yes	360.000	450.000	3	1623 x 760 x 704	1723 x 981 x 704	570	230/3/50-60	69	85	0
	MEF3603RCYD	Yes							400/3/50-60	38	47	0
	MEF3603RCY	No							400/3/50	38	47	122
MOD 3844	MEF3844RCVD	Yes	484.000	600.000	4	1950 x 634 x 700	2000 x 700 x 700	638	230/3/50-60	77	92	0
	MEF3844RCY	Optional							400/3/50	43	51	112
MOD 4323	MEF4323RCVD	Yes	432.000	540.000	3	1623 x 760 x 700	1723 x 1040 x 700	570	230/3/50-60	79	95	0
	MEF4323RCY	Optional							400/3/50-60	45	53	0
	MEF4323RCY	Optional							400/3/50	45	53	126
MOD 4804	MEF4804RCVD	Yes	480.000	600.000	4	2220 x 764 x 704	2387 x 1034 x 704	780	230/3/50-60	92	113	0
	MEF4804RCYD	Optional							400/3/50-60	51	63	0
	MEF4804RCY	Optional							400/3/50	51	63	134
MOD 5764	MEF5764RCVD	Yes	576.000	720.000	4	2220 x 764 x 704	2320 x 1044 x 704	780	230/3/50-60	105	126	0
	MEF5764RCYD	Optional							400/3/50-60	60	71	0
	MEF5764RCY	Optional							400/3/50	60	71	141



photo courtesy of Azimut-Benetti



The new EVA fan coils are a major step forward in both design and performance, the result of a 25 years' experience in the manufacture of marine air conditioning systems.

The new EVA series overcomes the main critical issues of marine air conditioning systems: effective removal of condensate water, blower position and efficiency and reduced noise and vibration.

The new Climma 'Dry pan' system ensures that all condensation water produced by the air conditioner drains away completely. All Climma fan coils are fitted with powerful blowers. The blowers are extremely quiet in operation and are fully adjustable on installation so they can be aligned correctly to the duct run, maximising efficiency of the air distribution.

EVA fan coils are all fitted with Climma's specially developed anti-vibration mounts stopping the transfer of structure noises.

Available in 11 sizes from 3.000 to 24.000 BTU/h capacity all with optional strip heaters for added comfort as required.

*I nuovi fan coil EVA, risultato di 25 anni di esperienza nel settore del condizionamento nautico, sono la perfetta combinazione di tecnica e di design.*

*I fan coil EVA risolvono infatti le principali problematiche del condizionamento nautico: l'effettiva rimozione dell'acqua di condensata, il posizionamento e l'efficienza dei ventilatori e la rumorosità del fan coil.*

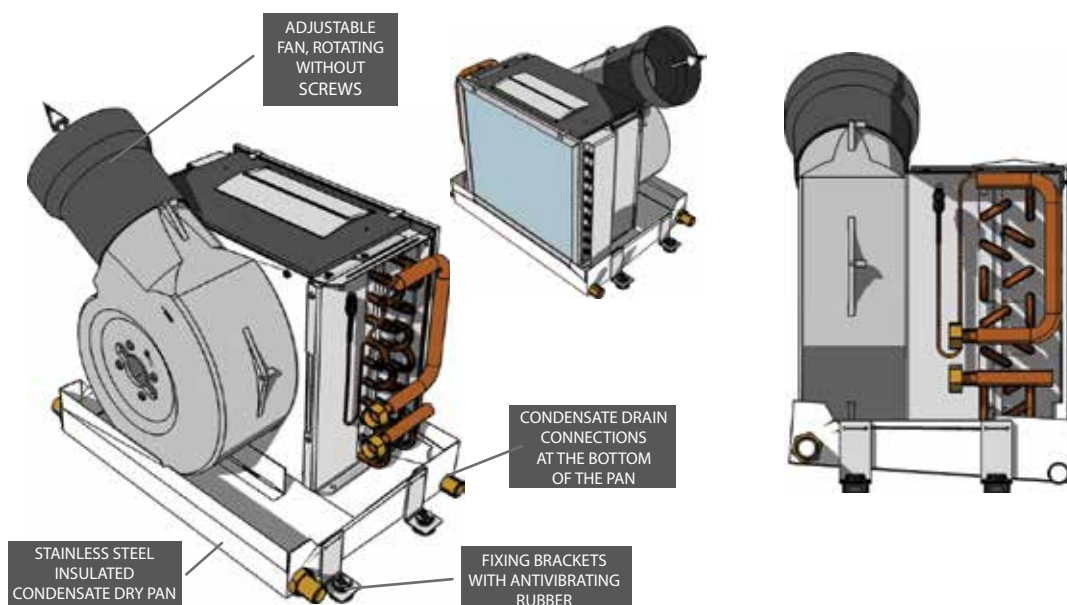
*Il nuovo concetto 'Dry Pan' è stato studiato per ridurre drasticamente il residuo di condensa. I fan coil EVA sono facili da installare e sono stati studiati con un comodo e potente ventilatore che può essere ruotato senza viti a seconda delle proprie esigenze, così da massimizzare l'efficienza nella distribuzione dell'aria.*

*Tutti i modelli sono equipaggiati con l'innovativo sistema anti-vibrazioni Climma, così da ottenere un fan coil tra i più silenziosi della sua categoria.*

*I fan coil EVA sono disponibili da 3.000 a 24.000 BTU/h con l'opzione a riscaldamento elettrico su richiesta.*

- QUIET, EASY TO INSTALL AND MAINTAIN
- FROM 3.000 TO 24.000 BTU/H
- UNIQUE 'DRY PAN' SYSTEM ENSURES CONDENSATE TRAY IS FULLY DRAINING, EVEN WHEN HEELING
- POWERFUL YET QUIET BLOWERS WITH EASY ALIGNMENT SYSTEM TO IMPROVE AIR FLOW
- ANTI-VIBRATION SYSTEM AS STANDARD

- SILENZIOSO E SEMPLICE DA INSTALLARE
- AMPIA GAMMA DA 3.000 FINO A 24.000 BTU/H
- INNOVATIVO SISTEMA 'DRY PAN' PER ASSICURARE IL PERFETTO DRENAGGIO DELL'ACQUA DI CONDENSA, ANCHE IN NAVIGAZIONE
- VENTILATORI POTENTI, SILEZIOSI E ORIENTABILI PER MIGLIORARE LA CIRCOLAZIONE DELL'ARIA
- SISTEMA ANTI-VIBRAZIONI CLIMMA DI SERIE



	Product Code	Nominal Power (Btu/h)	Air Flow (mq <sup>3</sup> /h)	Fan (nr)	Duct (mm)	W Fan (W)	Electrical Heater (W)	Weight (kg)	Size WxDxH (mm)
EVA 3	MEVA3J	3.000	176	1	75	56	-	6,0	322 x 178 x 219
EVA 4,5	MEVA45J	4.500	291	1	100	125	-	6,4	365 x 279 x 279
EVA 4,5 EH	MEVA45EJ	4.500	291	1	100	125	1300	6,4	365 x 279 x 279
EVA 7	MEVA7J	7.000	311	1	100	125	-	7,6	365 x 296 x 285
EVA 7 EH	MEVA7EJ	7.000	311	1	100	125	1300	7,6	365 x 296 x 285
EVA 9	MEVA9J	9.000	527	1	125	235	-	8,0	365 x 277 x 279
EVA 9 EH	MEVA9EJ	9.000	527	1	125	235	1300	8,0	365 x 277 x 279
EVA 13	MEVA13J	13.000	537	1	125	235	-	8,7	365 x 296 x 280
EVA 13 EH	MEVA13EJ	13.000	537	1	125	235	1300	8,7	365 x 296 x 280
EVA 17	MEVA17J	17.000	915	1	150	355	-	15,0	453 x 375 x 345
EVA 17 EH	MEVA17EJ	17.000	915	1	150	355	2000	15,5	453 x 375 x 345
EVA 17 SLIM	MEVA17SJ	17.000	1080	2	2x125	355	-	18,5	651 x 408 x 286
EVA 17 SLIM EH	MEVA17SEJ	17.000	1080	2	2x125	355	2600	18,5	651 x 408 x 286
EVA 17 EXTRA SLIM	MEVVA17SJ	17.000	1080	2	2x125	2x235	-	15,5	651 x 300 x 308
EVA 17 EXTRA SLIM EH	MEVVA17SEJ	17.000	1080	2	2x125	2x235	2600	15,5	651 x 300 x 308
EVA 24 SLIM	MEVA24SJ	24.000	1080	2	2x125	2x235	-	18,0	639 x 396 x 286
EVA 24 SLIM EH	MEVA24SEJ	24.000	1080	2	2x125	2x235	2600	18,0	639 x 396 x 286
EVA 24 EXTRA SLIM	MEVVA24SJ	24.000	1080	2	2x125	2x235	-	16,0	651 x 300 x 308
EVA 24 EXTRA SLIM EH	MEVVA24SEJ	24.000	1080	2	2x125	2x235	2600	16,0	651 x 300 x 308



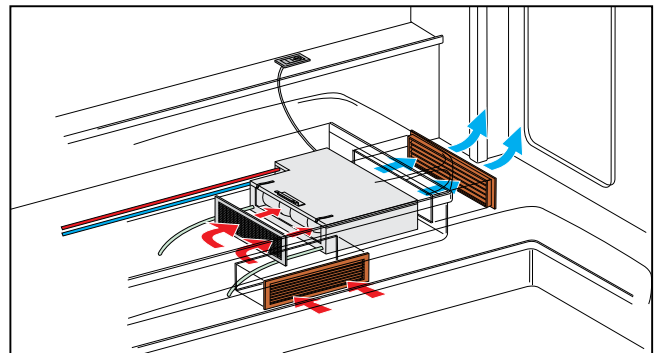
# CLIMMA FANCOILS FC AND FCV



FCV9



FC4



- EXTREMELY EASY TO INSTALL
- HIGH QUALITY EXTREMELY QUIET FAN FOR DIRECT AIR DUCTING
- HORIZONTAL OR VERTICAL INSTALLATION
- ALUMINIUM STRUCTURE WITH WHITE PAINT FINISHING
- MODELS FROM 2.000 TO 20,000 BTU/H
- ESTREMA SEMPLICITÀ DI MONTAGGIO
- VENTILATORE DI ALTA QUALITÀ SILENZIOSO CON MANDATA DIRETTA DELL'ARIA
- INSTALLAZIONE ORIZZONTALE O VERTICALE
- STRUTTURA IN LEGA LEGGERA RIVESTITA IN ALLUMINIO VERNICIATO
- MODELLI DA 2.000 FINO A 20.000 BTU/H

Product Code	Nominal Capacity (BTU / h)	Air flow (M3 / cu.ft)	Consumption (A)	Consumption (Watt)	Net Weigth (kg)	Weigth (kg)	Size (mm)
MFC2	<b>2.000</b>	203 / 119	0,19	42	5,5	7,5	353x344x167
MFC4	<b>4.000</b>	389 / 228	0,38	84	7,7	9,3	370x444x167
MFC6	<b>6.000</b>	534 / 314	0,39	87	8	10,5	422x444x192
MFC8	<b>8.000</b>	661 / 389	0,77	175	10,5	12,3	422x444x220
MFC12	<b>12.000</b>	850 / 500	0,77	175	12	13,8	446x544x435
MFC16	<b>16.000</b>	1052 / 619	0,78	174	13,9	16,3	446x644x225
MFC20	<b>20.000</b>	1096 / 645	0,78	174	-	-	446x744x225

Product Code	Nominal Capacity (BTU / h)	Air flow (M3 / cu.ft)	Consumption (A)	Consumption (Watt)	Net Weigth (kg)	Weigth (kg)	Size (mm)
MFCV25	<b>2.500</b>	171 / 100	0,19	42	-	-	370x320x155
MFCV5	<b>5.000</b>	309 / 181	0,38	84	-	-	375x385x155
MFCV9	<b>9.000</b>	441 / 259	0,39	87	-	-	505x385x186

## ELECTRONIC CONTROLS | *Scatole elettriche*

### MSCA\*

Climma 3 speed electronic control box for fan coils, for Climma mechanical control panels.

*Scheda di controllo fan coil Climma a 3 velocità, adatta al pannello di controllo meccanico Climma.*

### MV8\*

Electronic Climma control box for fan coils and control panel Climma MK2. Best control of the room temperature thanks to 8 speeds.

*Scheda di controllo fan coil Climma, adatta al pannello di controllo digitale Climma MK2. Massimo controllo della temperatura grazie alle 8 differenti velocità.*

MODBUS COMMUNICATION AVAILABLE FOR MV8 MODELS | *Modbus disponibile per i modelli MV8*

## CONTROL PANELS | *Pannelli di controllo*

### MECHANICAL CONTROL PANEL AVE | *Pannello meccanico*

Climma 3 speed mechanical control panels. Easy and reliable system.

*Pannello di controllo meccanico Climma, affidabile e semplice da utilizzare.*

### MK2\* | DIGITAL CONTROL PANEL MK2 | *Pannello digitale*

The Climma Vega Mk2 digital control panel has been designed specifically for ease of use. The display shows the ambient temperature, while parameters can be changed with a simple push-button sequence.

The Climma Vega Mk2 digital panel automatically controls temperature and ventilation. The panel comes in black or silver finishing and it can also be integrated in all the switches lines of the most popular brands.

*La facilità d'uso è la caratteristica che spicca nel controllo digitale Vega Mk2. Il display indica e controlla la temperatura dell'ambiente ed è disponibile con finitura nera o argentata, integrandosi perfettamente con tutte le linee di interruttori, dei più importanti e prestigiosi produttori di componenti.*



REMOTE CONTROL  
*Telecomando*  
(code. MTELE)



### MPACT\* | CLIMMA C-TOUCH NEW CONTROL | *Pannello Climma C-Touch*

The new Climma C-TOUCH thermostats has been designed to be easy to use and simple, to get the best out of your climate control.

C-TOUCH is compatible with Climma self-contain Compact solutions and Climma fancoils, and allows for a weekly scheduler, customizable interfaces and colors and it's designed for most of the Vimar and BTicino cover plates.

*Il nuovo termostato Climma C-TOUCH, studiato per essere semplice ed intuitivo, permette un controllo a 360° del comfort a bordo. Compatibile con tutti gli impianti Climma, sia Compact che fancoil, permette la programmazione settimanale, la personalizzazione delle interfacce anche per colore ed è compatibile con le più comuni placche Vimar e BTicino.*

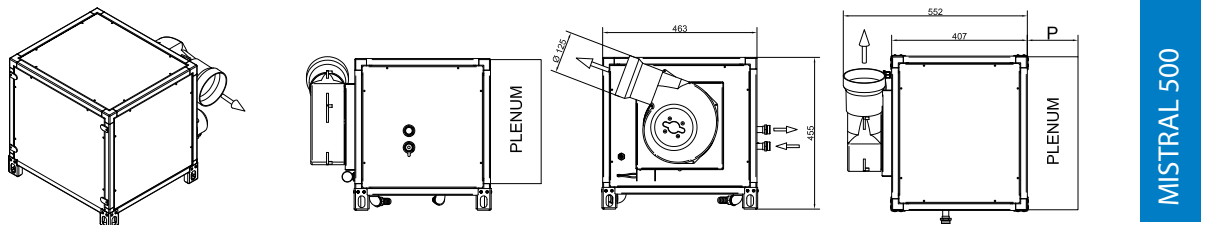


# CLIMMA MISTRAL FRESH AIR UNITS

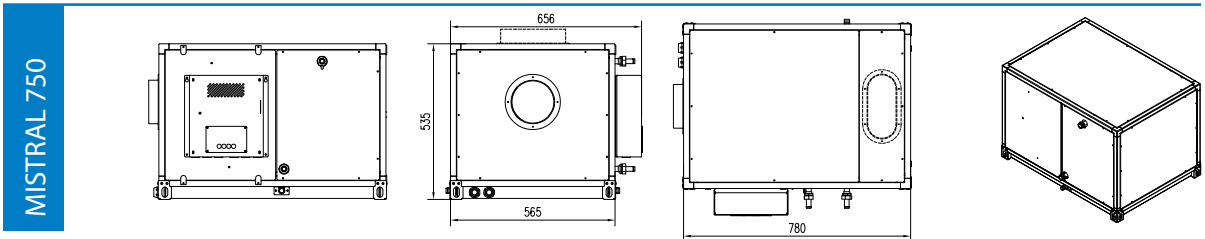


photo courtesy of Azimut-Benetti

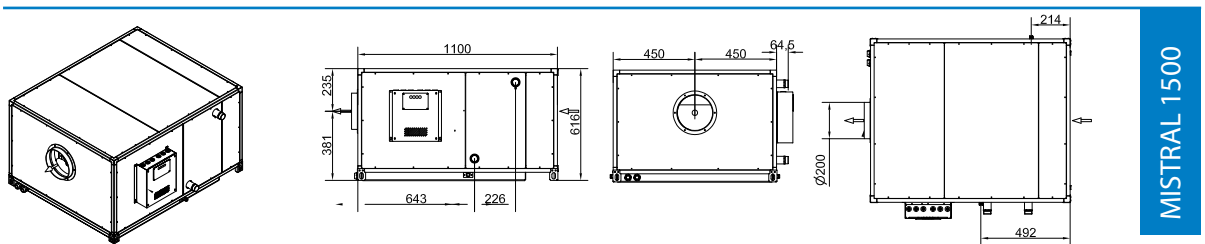
	Product Code	Nominal Capacity (Btu/h)	Air flow (M3/h - ft3/m)	Consumption in cool (A)	Consumption in heat (A)	net Weight (Kg)	shipping Weight (Kg)	HxWxD (D2) (mm)	Electrical box (WxHxD mm)	Post heater (W)
<b>Mistral 500 standard</b>	TA2255	20.000	500 - 293	11,0	1,1	27	34	455x552x463	280x287x90	2000
<b>Mistral 750 standard</b>	TA0656	45.000	750 - 441	16,0	1,6	49	57	535x780x565	280x287x90	3360
<b>Mistral 1500 standard</b>	TA1285A	90.000	1500 - 882	32,0	2,5	96	96	819x1100x900	280x287x90	6720



MISTRAL 500



MISTRAL 750

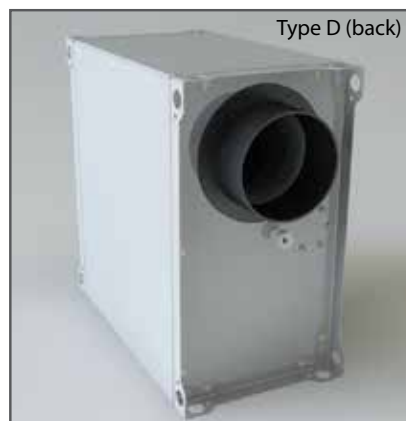


MISTRAL 1500



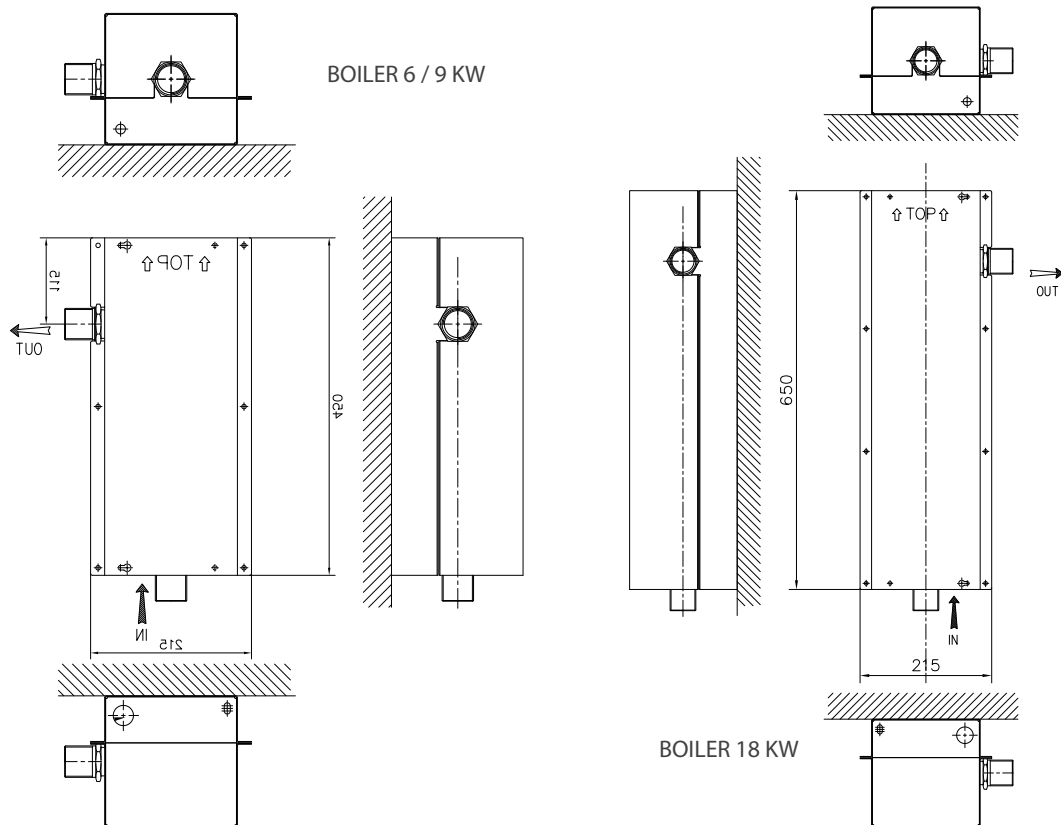
	MEST2U*		MEST4U*		MEST6U*		MEST9U		MEST10U	
Alimentazione – Power Supply	230/1/50	230/1/60	230/1/50	230/1/60	230/1/50	230/1/60	230/1/50	230/1/60	230/1/50	230/1/60
Consumo – Power consumption (A)	0,58	-	0,75	-	1,05	1,23				
Consumo – Power consumption (W)	130	-	170	-	240	250				
(RPM)	2550		1500		2100	2100				
Portata d'aria – Air flow (m3/h)	200		400		600		900		1000	
Dim.condotta ingresso – Air duct In (A,B models)	100 mm		100 mm		100 mm		150 mm		200 mm	
Dim.condotta ingresso – Air duct In (C,D models)					50 mm x 5, 75 mm x 3		-		-	
Dim. Condotta uscita - Air duct Out	100 mm		100 mm		100 mm		150 mm		200 mm	
Dimensioni – Size (hwxwd mm)	320x180x330		320x180x330		320x180x330		400x355x355		515x470x470	

<b>A</b>	1 FRONT IN, 1 BACK OUT
	1 INGRESSO FRONTALE, 1 USCITA DIETRO
<b>B</b>	1 FRONT IN, 1 FRONT OUT
	1 INGRESSO FRONTALE E 1 USCITA FRONTALE
<b>C</b>	3 FRONT IN, 1 BACK OUT
	3 INGRESSI FRONTALI, 1 USCITA DIETRO
<b>D</b>	5 FRONT IN, 1 BACK OUT
	5 INGRESSI FRONTALI, 1 USCITA DIETRO



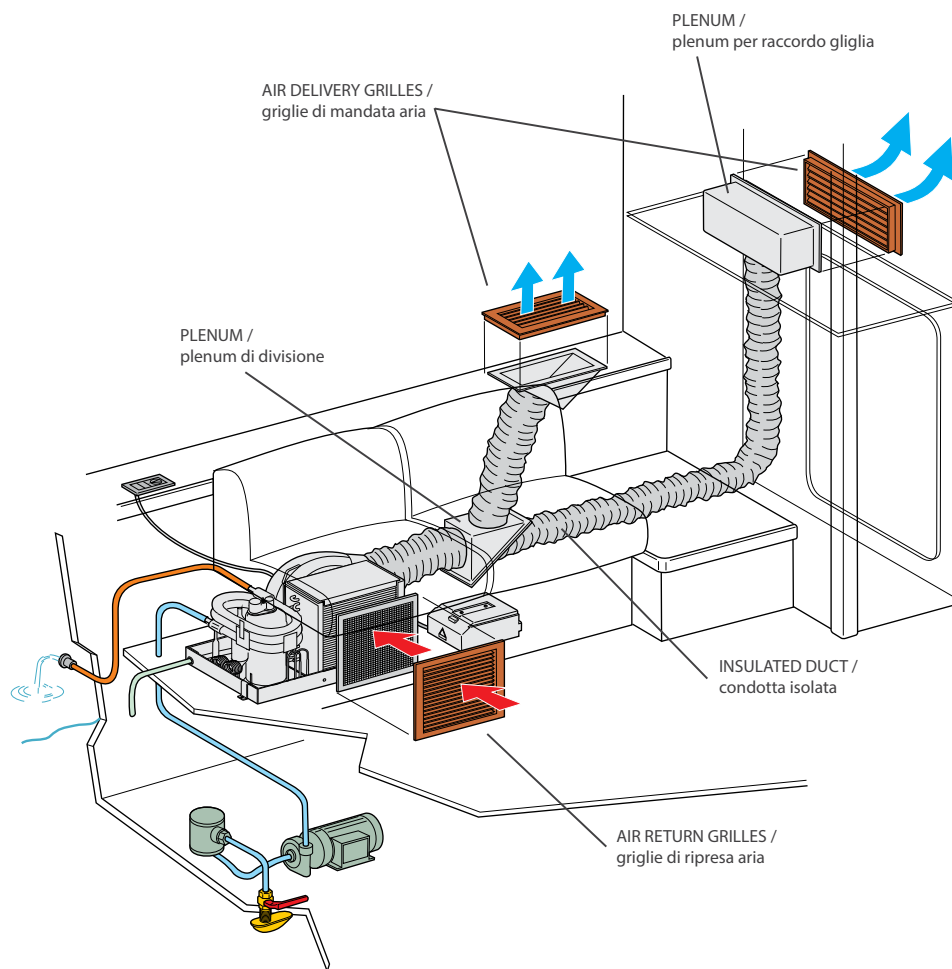


	Product code / Codice Vecco	Power Supply / Alimentazione	Connection Type / Tipo connessione	Electrical Resistance / Resistenza Elettrica	Resistance Value / Valore Resistenza (Ω)	Consumption / Consumo (A)	Hoses / Tubi (mm <sup>2</sup> ) *	Size (mm) / Dimensione**	Minimum flow / Flusso min.(m3/h)
6 kW	MBOI6U4	230/1/50	Parallel	-	-	26	6	450x215x176	1
	MBOI6U5	230/1/50	2 steps	M74600	26,45	26	6		
	MBOI6V1	230/3/50-60	Y/Δ: star-triangle	M74600	26,45	15	2,5		
	MBOI6Y1	400/3/50	Y/Δ: star-triangle	M72055	80,00	9	2,5		
	MBOI6Y2	400/3/50	Δ: Triangle	M72055	80,00	9	2,5		
MBOI6Z1	460/3/60	Y/Δ: star-triangle	-	-	8	2,5			
9 kW	MBOI9U4	230/1/50	Parallel	-	-	40	10	450x215x176	1,5
	MBOI9U5	230/1/50	2 steps	M73365	17,63	40	10		
	MBOI9V1	230/3/50-60	Y/Δ: star-triangle	M73365	17,63	23	4		
	MBOI9V2	230/3/50	Δ: Triangle	M73365	17,63	23	4		
	MBOI9Y1	400/3/50	Y/Δ: star-triangle	M72060	53,33	13	2,5		
	MBOI9Y2	400/3/50	Δ: Triangle	M72060	53,33	13	2,5		
	MBOI9Z1	460/3/60	Y/Δ: star-triangle	-	-	11	2,5		
18 kW	MBOI18V1	230/3/50-60	Y/Δ: star-triangle	M72095	8,82	45	16	650x215x176	3
	MBOI18V2	230/3/50	Δ: Triangle	M72095	8,82	45	16		
	MBOI18Y1	400/3/50	Y/Δ: star-triangle	M72065	26,67	26	6		
	MBOI18Y2	400/3/50	Δ: Triangle	M72065	26,67	26	6		
	MBOI18Z1	460/3/60	Y/Δ: star-triangle	-	-	23	4		



Climma offer a wide range of air accessories, for every kind of air conditioning system and yacht interior; air grilles, plenum, duct nipples and joints, splitters and insulated duct.

Climma offre una gamma completa di accessori per l'aria adatti a qualsiasi tipo di impianto di condizionamento e a qualsiasi tipo di arredamento. Dalle griglie, con diverse gamme tra cui scegliere, ai plenum, adattatori, raccordi e giunzioni per condotte, condotte.



## AIR DISTRIBUTION KITS FOR COMPACT AND FANCOIL | Kit aria per compact e fancoil Climma

Air Kit		Air Kit	
COMPACT 3.5 / 4.2	AIR KIT 2	FANCOIL MEV 3	AIR KIT 2
COMPACT 5 (split 4)	AIR KIT 2	FANCOIL MEV 45	AIR KIT 2
COMPACT 7 (split 7)	AIR KIT 2	FANCOIL MEV 7	AIR KIT 2
COMPACT 9 (split 9)	AIR KIT 2	FANCOIL MEV 9	AIR KIT 3
COMPACT 10 (split 10)	AIR KIT 3	FANCOIL MEV 13	AIR KIT 3
COMPACT 12 (split 12)	AIR KIT 3	FANCOIL MEV 15	AIR KIT 5
COMPACT 16 (split 16)	AIR KIT 4	FANCOIL MEV 17	AIR KIT 4
COMPACT 17	AIR KIT 5	FANCOIL MEV 17S	AIR KIT 6
COMPACT 24	AIR KIT 6	FANCOIL MEV 24S	AIR KIT 8
COMPACT 27	AIR KIT 7		

VECO AIR KIT	RETURN AIR GRILL Codice griglia ripresa	SUPPLY AIR GRILL Codice griglia mandata	PLENUM plenum	DUCT NIPPLE raccordo condotta	INSULATED DUCT condotta isolata
AIR KIT 1	MG*A2525 (252 x 252 cm)	MG**2010 (200 x 100 cm)	M3277B	M3241A	M3355A
AIR KIT 2	MG*A2525 (252 x 252 cm)	MG**2010 (200 x 100 cm)	M3277B	M3241B	M3355B
AIR KIT 3	MG*A2525 (252 x 252 cm)	MG**3010 (300 x 100 cm)	M3244A	M3240A	M3355C
AIR KIT 4	MG*A3525 (352x 252 cm)	MG**4010 (400 x 100 cm)	M3244B	M3240B	M3355D
AIR KIT 5	MG*A3525 (352x 252 cm)	2x MG**2010 (200 x 100 cm)	2x M3277B	2x M3241B	M3355B
AIR KIT 6	MG*A3525 (352x 252 cm)	2x MG**3010 (300 x 100 cm)	2x M3244A	2x M3240A	M3355C
AIR KIT 7	2x MG*A3525 (352 x 252 cm)	2x MG**4010 (400 x 100 cm)	2X M3244B	2x M3240B	M3355D
AIR KIT 8	MG*A3525 (352x 252 cm)	2x MG**4010 (400 x 100 cm)	2X M3244B	2X M3240A	M3355C

## FINISHING / Finiture disponibili

- (A) ALUMINIUM / alluminio classico
- (N) BLACK ALUMINIUM / alluminio nero
- (W) WHITE ALUMINIUM / alluminio bianco (RAL 9010)
- (T) TEAK WOOD / legno teak

## GRILL TYPE / Modello

- (S) AIR DELIVERY GRILL | griglia di mandata
- (C) CLOSABLE AIR DELIVERY GRILL | griglia di mandata chiudibile
- (A) AIR INTAKE GRILL | griglia di aspirazione

## CUSTOM GRILLES / Griglie custom

Veco produces custom grilles, with almost every size and finishing. Example of other finishings available are: Aluminium painted RAL, Cherry, Mahogany and Durmast.

## SUPPLY GRILLES | Griglie di mandata

### SUPPLY AIR GRILLES / Griglie di mandata

	100 x 100 mm (4 x 4 inch)	200 x 200 mm (8 x 4 inch)	300 x 100 mm (12 x 4 inch)	400 x 100 mm (16 x 4 inch)
Aluminium (silver) / Alluminio (argento)	MGAS1010	MGAS2010	MGAS3010	MGAS4010
Aluminium (Black) / Alluminio (nero)	MGNS1010	MGNS2010	MGNS3010	MGNS4010
Aluminium (White) / Alluminio (bianco)	MGWS1010	MGWS2010	MGWS3010	MGWS4010
Wood (teak) / Legno teak	MGTS1010	MGTS2010	MGTS3010	MGTS4010



### SUPPLY AIR GRILLES (CLOSABLE) / Griglie di mandata (chiudibili)

	100 x 100 mm (4 x 4 inch)	200 x 200 mm (8 x 4 inch)	300 x 100 mm (12 x 4 inch)
Aluminium (silver) / Alluminio (argento)	MGAC1010	MGAC2010	MGAC3010
Aluminium (Black) / Alluminio (nero)	MGNC1010	MGNC2010	MGNC3010
Aluminium (White) / Alluminio (bianco)	MGWC1010	MGWC2010	MGWC3010
Wood (teak) / Legno teak	MGTC1010	MGTC2010	MGTC3010

## RETURN AIR GRILLES | griglie di aspirazione

	252 x 252 mm (10 x 10 inch)	354 x 252 mm (14 x 10 inch)
Aluminium (silver) / Alluminio (argento)	MGAA2525	MGAA3525
Aluminium (Black) / Alluminio (nero)	MGNA2525	MGNA3525
Aluminium (White) / Alluminio (bianco)	MGWA2525	MGWA3525
Wood (teak) / Legno teak	MGTA2525	MGTA3525



## ROUND PLASTIC GRILLES | Griglie in plastica rotonde

Product Code	Color	Diameter (mm - inch)	Type
M3639	BLACK	75 - 4	closable, orientable
M67150	BLACK	100 - 5	closable, orientable
M67145	WHITE	100 - 5	closable, orientable
M70485	LIGHT BEIGE	100 - 5	closable, orientable



## DUCT ACCESSORIES | Accessori per condotte

### DUCT NIPPLES | Raccordi condotta

Product Code	Duct diameter (mm - inch)	Shape
M3241A	75 - 3	round
M3241B	100 - 4	round
M3240A	125 - 5	oval
M3240B	150 - 6	oval
M3240C	175 - 7	oval



### DUCT JOINTS | Giunzioni per condotta aria

Product Code	Duct diameter (mm - inch)	length
M3364A	75 - 3	100 - 4
M3364B	100 - 4	100 - 4
M3364C	125 - 5	100 - 4
M3364D	150 - 6	120 - 4.7
M3364E	175 - 7	120 - 4.7





# PLENUMS AND ACCESSORIES | *Plenum e accessori*

## RECTANGULAR | *Rettangolari*

Product Code	Internal size (mm - inch. approximate)
M3244A	330X145X150 - 13x6x6
M3244E	380X320X150 - 15x13x6
M3244B	430X145X150 - 17x6x6
M3244C	430X205X200 - 17x8x8
M3244D	630X145X150 - 25x6x6

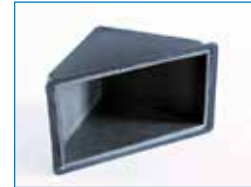


Product Code	Shape	Duct connection	Size (mm - inch)
M72790	Duct connection on the side	100 - 4	152x152x113 - 6x6x4.4
M72795	Duct connection below	100 - 4	152x152x133 - 6x6x5.3



## TRIANGULAR | *Triangolari*

Product Code	Internal size (mm - inch. approximate)	side opening (mm - inch)	front opening (mm - inch)	Cover code	Cover size (mm - inch)
M3277A	230X131X145 - 9x5x6	100 - 4	75 - 3	M3276A	252x154 - 10x6
M3277B	256X131X160 - 10x5x6	125 - 5	100 - 4	M3276B	278x154 - 11x6
M3277C	316X131X185 - 13x5x7	150 - 6	125 - 5	M3276C	340x154 - 13x6



## 3-WAY SPLITTER PLENUM | *Plenum triangolare a 3 vie*

Product Code	Z exit (mm - inch)	Y exit (mm - inch)	X exit (mm - inch)
M3361A	75 - 3	75 - 3	75 - 3
M3361B	100 - 4	75 - 3	75 - 3
M3361C	100 - 4	100 - 4	75 - 3
M3361D	100 - 4	100 - 4	100 - 4
M3362H	100 - 4	100 - 4	175 - 7
M3362I	100 - 4	125 - 5	175 - 7
M3363A	100 - 4	150 - 6	175 - 7
M3361E	125 - 5	75 - 3	75 - 3
M3361F	125 - 5	100 - 4	75 - 3
M3361G	125 - 5	100 - 4	100 - 4
M3362M	125 - 5	125 - 5	75 - 3
M3362A	125 - 5	125 - 5	100 - 4
M3362B	125 - 5	125 - 5	125 - 5
M3362L	125 - 5	125 - 5	175 - 7
M3363D	125 - 5	150 - 6	150 - 6
M3363B	125 - 5	150 - 6	175 - 7
M3362C	150 - 6	100 - 4	75 - 3
M3362D	150 - 6	100 - 4	100 - 4
M3362E	150 - 6	125 - 5	75 - 3
M3362F	150 - 6	125 - 5	100 - 4
M3362G	150 - 6	125 - 5	125 - 5
M3363E	150 - 6	150 - 6	125 - 5
M3363F	150 - 6	150 - 6	100 - 4
M3363L	150 - 6	150 - 6	150 - 6
M3363C	150 - 6	150 - 6	175 - 7



## INSULATED DUCT | *Condotta isolata*

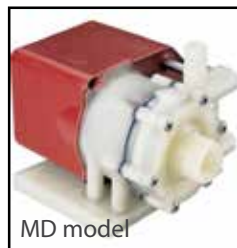
Product Code	Ext. Diameter (mm - inch)	Int. Diameter (mm - inch)
M3355A	75 - 3	125 - 5
M3355B	100 - 4	150 - 6
M3355C	125 - 5	175 - 7
M3355D	150 - 6	200 - 8
M3355E	175 - 7	225 - 9



## SEA WATER PUMPS | Pompe acqua mare

Chiller Capacity / Capacità chiller Up to - fino a	Model / Modello	Part nr. / Codice	Pump flow rate / Portata pompa		Pump head / Prevalenza		Power / Consumo W	Weight / Peso Kg - lb	Ports / Attacchi		Calibration valve / Valvola
			L/m	Mc/h	Mt	Ft			delivery /	intake /	
17.000 Btu/h	MD 120	<b>M3353*</b>	14	0,8	4	13	120	3,5 - 7,7	½ MTP	1' FTP	M85380B
30.000 Btu/h	TMB65	<b>M73295*</b>	25	1,5	5	15	135	5 - 10	1' M BSP	1' M BSP	M85380A
72.000 Btu/h	B-C20/A	<b>M67270*</b>	60	3,6	11	33	370	9,5 - 20,9	1' F BSP	1' F BSP	M85380A
120.000 Btu/h	B-C22/1/A	<b>M67611*</b>	100	6,0	10	33	450	10,5 - 23,1	1' F BSP	1' F BSP	M85380C
300.000 Btu/h	B-C41/1E	<b>M67275*</b>	250	15,0	13	32	750	18 - 40	1-1/2' F BSP	1-1/2' F BSP	M85380D
500.000 Btu/h	B-NM 40/12F	<b>M67280*</b>	500	30,0	8	26	1100	33 - 72,7	PN16-40 **	PN16-65 **	M85380E
800.000 Btu/h	B-NM 50/12F/A	<b>M81140*</b>	800	48,0	12	39	2200	63-138,9	PN16-50 **	PN16-65 **	M85380F

U = 230/1/50
J = 230/1/50-60
I = 115/1/60
W = 208-230/1/60
Y = 400/3/50
V = 230/3/50
X = 208/3/60
Z = 460/3/60



## SEA WATER STRAINER | Filtri acqua mare

Prod.Code	Description
M70665	Sea water strainer 1/2 BSP
M3334D	Sea water strainer 1' BSP
M3334E	Sea water strainer 1-1/2' BSP



## SEA WATER INTAKE | Presa mare

Prod.Code	Description
M64215	Sea water intake 1/2"
M64216	Sea water intake 3/4"
M64210	Sea water intake 1"
M64217	Sea water intake 1" ¼



## SEA WATER OUTLET | Scarico acqua mare

Prod.Code	Description
M64825	Sea Water Outlet 1/2"
M64830	Sea Water Outlet 1"



## PUMP ACCESSORIES | Accessori pompe

Prod.Code	Description	Power in	Power out
M82820	Main supply for self priming pump A092819C	110-230/50-60Hz	12V - 2A - 24W

## PUMP RELAY BOX | Scatola relay per pompa

Prod.Code	Description	Power supply
MREL2I	Pump relay box for 2 units	115V
MREL2U	Pump relay box for 2 units	230V
MREL6I	Pump relay box for 3-6 units	115V
MREL6U	Pump relay box for 3-6 units	230V

## FRESH WATER PUMPS | *Pompe acqua dolce*

Veco Part nr.	Fancoil total Capacity (btu/h)	Pump Model	W	Nominal flow rate		Head		Air Bleeder	Expansion Tank	Delivery port	Intake port	Weight	
				L/m	GPM	Mt	Ft					Kg	Lb
M67285*	12.000	NM 1/AE	370	15	4	22	73	1' - M66660	5 lt	1' F BSP	1' F BSP	8,6	21,5
M67285*	24.000	NM 1/AE	370	25	6	21	69	1' - M66660	5 lt	1' F BSP	1' F BSP	8,6	21,5
M67290*	36.000	NM 2/S/A	550	30	8	29	96	1' - M66660	5 lt	1' F BSP	1' F BSP	14,2	35,5
M67290*	48.000	NM 2/S/A	550	40	10	27	89	1' - M66660	8lt	1' F BSP	1' F BSP	14,2	35,5
M67295*	60.000	NM 25/12A/A	750	50	13	23	76	1' - M66660	8lt	1' F BSP	1-1/2' F BSP	14,2	35,5
M67295*	72.000	NM 25/12A/A	750	60	15	23	76	1' - M66660	8lt	1' F BSP	1-1/2' F BSP	14,2	35,5
M67295*	84.000	NM 25/12A/A	750	70	18	23	76	1' - M66660	8lt	1' F BSP	1-1/2' F BSP	14,2	35,5
M67295*	96.000	NM 25/12A/A	750	80	20	22	73	1' - M66660	12 lt	1' F BSP	1-1/2' F BSP	14,2	35,5
M67300*	150.000	NM 10/AE	1100	125	31	23	76	1-1/4' - M66665	12 lt	1-1/4' F BSP	2' F BSP	20,2	50,5
M67300*	200.000	NM 10/AE	1100	160	40	22	73	1-1/4' - M66665	18 lt	1-1/4' F BSP	2' F BSP	20,2	50,5
M81850*	250.000	NM 11/BE	1500	200	50	22	73	1-1/4' - M66665	18 lt	1-1/4' F BSP	2' F BSP	24,7	61,8
M67305*	300.000	NM 40/16C/B	2200	250	63	23	76	1-1/2' - M66670	24 lt	PN16-40**	PN16-65**	39,0	97,5
M67305*	400.000	NM 40/16C/B	2200	315	79	22	73	1-1/2' - M66670	24 lt	PN16-40**	PN16-65**	39,0	97,5
M71795*	500.000	NM 50/16B/B	5500	500	125	31	102	2' - M66796	2x24lt	PN16-50**	PN16-65**	64,0	160,0
M71795*	700.000	NM 50/16B/B	5500	630	158	29	96	2' - M66796	2x24lt	PN16-50**	PN16-65**	64,0	160,0

## AUTOMATIC AIR BLEEDER | *Disareatori*

Code	Description
M66795	Automatic air bleeder 3/4"
M66660	Automatic air bleeder 1"
M66665	Automatic air bleeder 1"1/4
M66670	Automatic air bleeder 1"1/2
M66796	Automatic air bleeder 2"



## EXPANSION TANK | *Vasi d'espansione*

Code	Description
M3603A	Expansion tank 5 liters
M3603B	Expansion tank 8 liters
M3603C	Expansion tank 12 liters
M3603D	Expansion tank 18 liters
M3603E	Expansion tank 24 liters



## FAN COIL MANIFOLD | *Collettori fan-coil*

Code	Description
M62815	Fan Coil Manifold 1"x2
M62820	Fan Coil Manifold 1"x3
M62825	Fan Coil Manifold 1"x4
M62830	Fan Coil Manifold 1"x5
M62835	Fan Coil Manifold 1"x6
M62775	Fan Coil Manifold 1"x7
M62780	Fan Coil Manifold 1"x8
M62840	Fan Coil Manifold 1"x9
M62845	Fan Coil Manifold 1"x10



## GAUGE MANIFOLD FOR CWS | *Kit manometro*

Code	Description
M65261	Gauge manifold for CWS



## FAN COIL HOSE | *Tubi fancoil isolati*

Code	Description	Insulation	Diameter	Outer diam.
M67575B	Flexible reinforced hose 16 mm	9mm	16mm	40mm
M67575C	Flexible reinforced hose 25 mm	9mm	25mm	50mm

## WATER VALVES FOR FAN COILS | *Valvole acqua fan-coil*

Code	Description	Power Supply
M76660	Water valve Johnson for Fan Coil FC - 4 ways	230/1/50-60 Hz
M76660J	Water valve Johnson for Fan Coil EV - 4 ways	230/1/50-60 Hz



## CLIMMA MISTIFIER SYSTEM H2OASI



photo courtesy of Azimut-Benetti

	H2Oasi	H2Oasi Plus
Codice Prodotto - Code	NOASI420ESU	NOASI420ECU
Area coperta - Covered Area (Mq)	25 - 65	30 - 90
N° ugelli da 0,2 - N° noozles 0,2	from 4 to 16	from 4 to 16
N° ugelli da 0,1 - N° noozles 0,1	From 5 to 30	From 5 to 30
Consumo acqua ugello 0,2 - Noozle water consumption 0,2 (L/h)	4,75	4,75
Consumo acqua ugello 0,1 - Nnoozle water consumption 0,1 (L/h)	2,5	2,5
Pressione - Pressure (Bar)	70	70
Alimentazione - Power Supply	230/1/50	230/1/50
Consumo - Consumption (W)	250	250
Consumo - Consumption (A)	1,6	1,6
Peso - Weight (Kg)	21	25

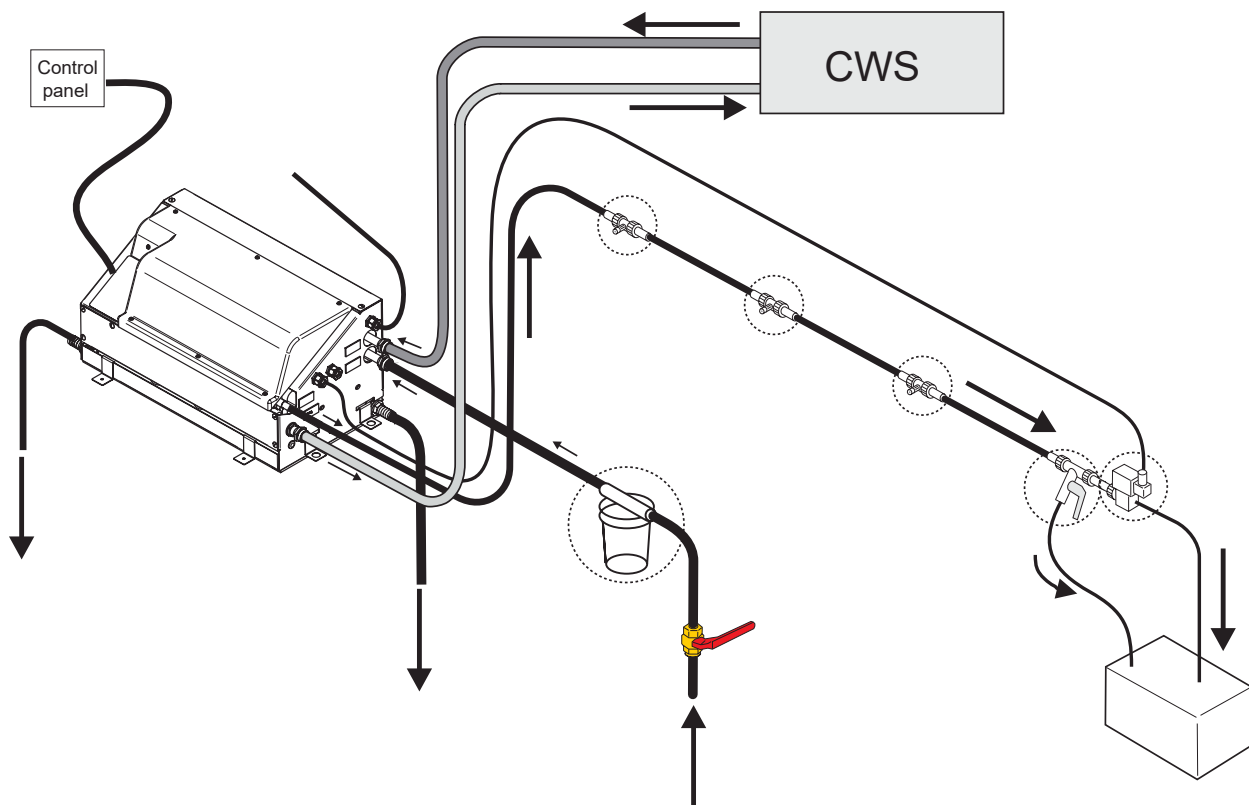


**Climma H2Oasi** high pressure mistifier is the perfect solution for outside cooling; using the adiabatic cooling, Climma H2Oasi uses the ambient heat energy to evaporate the water in the system, cooling down the ambient temperature.

In order to instantly evaporate the water, Climma H2Oasi uses special pressurizing systems that work with high pressure, over 80 Bar, and thanks to very small nozzles, the system guarantees the water to be nebulized in drops of a few microns.

*I nebulizzatori ad alta pressione **Climma H2Oasi** sono la soluzione ideale per il raffrescamento in esterno; grazie al principio fisico del raffrescamento adiabatico, il sistema Climma H2Oasi sfrutta il calore presente nell'ambiente per far evaporare l'acqua e abbassare la temperatura dell'ambiente.*

*Per rendere istantanea l'evaporazione delle molecole d'acqua, il nebulizzatore Climma H2Oasi utilizza speciali sistemi di pressurizzazione che operando ad oltre 70bar di pressione e grazie a speciali linee flessibili dotate di ugelli ceramici micrometrici, garantiscono una nebulizzazione in gocce del diametro di pochi micron.*





# frigoboat®

## MARINE REFRIGERATION

### FRIGOBOAT MARINE REFRIGERATION

#### *Frigomatic D.C. refrigeration systems*

---

FRIGOMATIC COMPRESSORS	39
EVAPORATORS	41
KEEL COOLERS	43
ACCESSORIES	43

#### *A.C. refrigeration systems*

---

A.C. REFRIGERATION SYSTEMS	45
----------------------------	----

#### *Frigoboat cabinets*

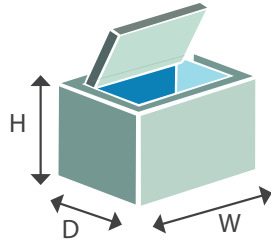
---

FRIGOBOAT MS SERIE	46
ICE MAKERS	49
FRIGOBOAT CUSTOM LINE	50
FRIGOBOAT COLD ROOMS	52

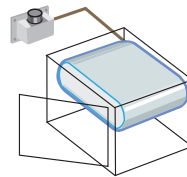
**CHOOSE YOUR FRIGOMATIC SYSTEM**

**1) Calculate the volume of the fridge/freezer**  
*Calcola il volume del vano da refrigerare*

$$\text{Volume} = \frac{D \times W \times H}{1000}$$

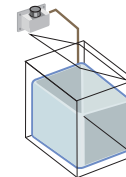


**2) Choose the evaporator that best suits your box**  
*Scegli l'evaporatore più adatto al tuo vano*



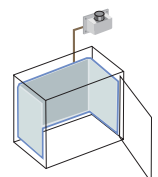
**SERIES H & B**  
Ideal for fridges with freezer compartments

*Ideale per frigo con vano freezer a celletta*



**SERIES B & H**  
Ideal for fridges with freezer compartments or as dedicated freezer

*Ideale per frigo con vano freezer, o come freezer dedicati*



**SERIES F**  
Ideal for top loading fridges or freezers

*Ideale per frigo o freezer a pozzetto*

**3) Select the most suitable condensing unit**  
*Scegli la motocondensante più adatta*

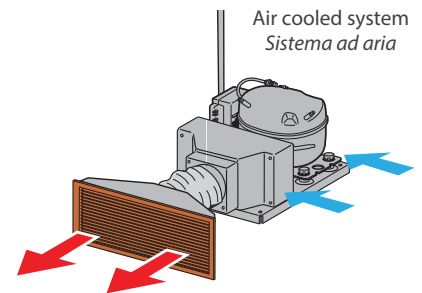
**AIR COOLED UNIT | Raffreddamento ad aria**

An air-cooled system is less efficient than a water cooled system but is cheaper and easier to install. To achieve maximum efficiency, the coolest available air source should be fanned across an aluminium fin condenser, and the heated air expelled away to a different area.

Choose air cooled for Northern European cruising.

*Un sistema con raffreddamento ad aria è meno efficiente di uno ad acqua, ma è più economico e più semplice da installare a bordo. Per ottenere la massima efficienza dal sistema, l'aria fresca va convogliata, tramite un ventilatore, allo scambiatore alettato, per poi essere espulsa in una zona lontana dall'aspirazione.*

*Scegli un sistema ad aria per navigazioni in clima nord-europeo o mediterraneo.*



Air cooled system  
*Sistema ad aria*

**WATER COOLED UNIT | Raffreddamento ad acqua**

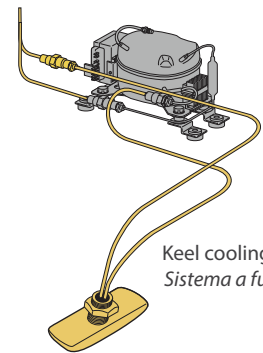
A water-cooled system is more efficient than an air cooled one because water dissipates heat far better than air. Keelcooling is also more efficient, reliable and quieter than a pump water cooled system as the only moving part required is the compressor.

Choose a water cool if you are planning to cruise the Mediterranean or Tropics.

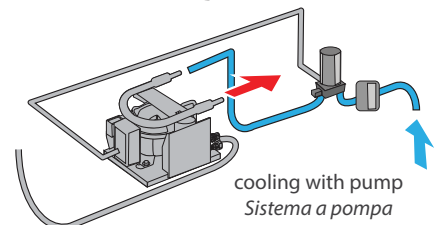
*Un sistema con raffreddamento ad acqua è più efficiente di un sistema ad aria perchè l'acqua dissipa il calore molto più velocemente.*

*Un sistema a fuoriscafo è ancora più efficiente, affidabile e silenzioso rispetto al raffreddamento a pompa, perchè l'unico componente in movimento rimane il compressore.*

*Scegli un sistema ad acqua per navigazioni in clima mediterraneo o tropicale.*



Keel cooling system  
*Sistema a fuoriscafo*



cooling with pump  
*Sistema a pompa*

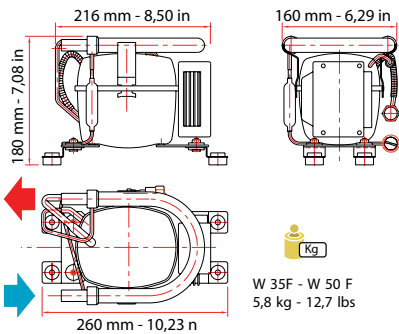
**4) Select the thermostat that best fits your system**  
*Scegli il termostato più adatto al tuo sistema*





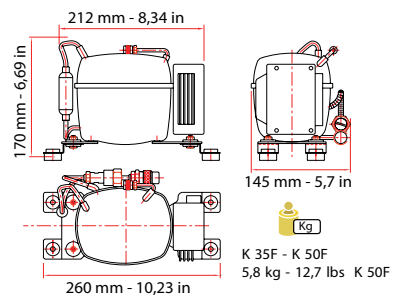
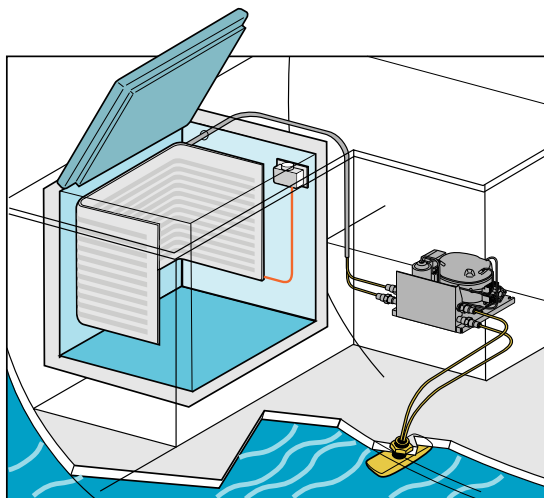
**WATER COOLED COMPRESSORS | compressore ad acqua**

	MAX CAPACITY FRIDGE (lt)	MAX CAPACITY FREEZER (lt)	CODE	RPM	CAPACITY (Btu/h)	CONSUMPTION		NET WEIGHT (kg)	GROSS WEIGHT (kg)	SIZE (WxDxH*)	REFRIGERANT
						(A)	(W)				
<b>W 35 F</b>	340	100	<b>E50045X</b>	2000	326	4,00	45	5,8	6,6	260x160x180	r134a
				2500	406	4,70	56				
				3000	471	5,70	66				
				3500	540	6,80	81				
<b>W 50</b>	380	100	<b>E51970</b>	2000	369	4,00	45	5,8	-	260x232x180	r134a
				2500	472	4,70	56				
				3000	560	5,70	66				
				3500	650	6,80	81				



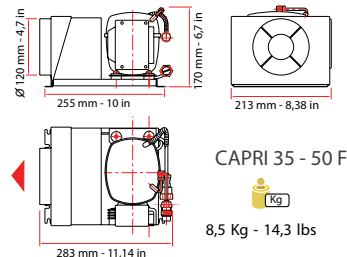
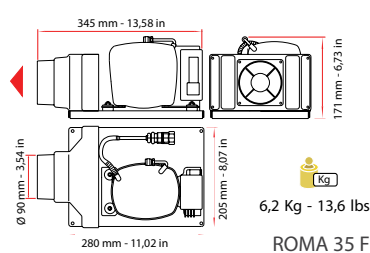
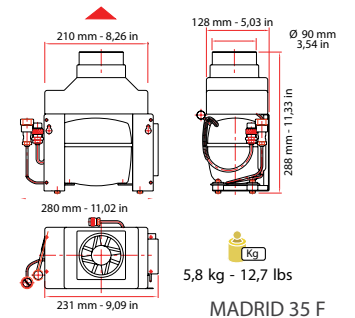
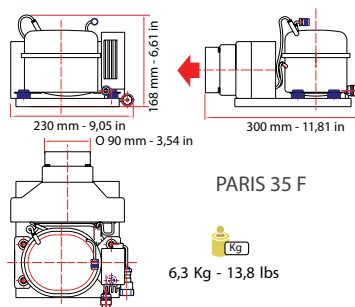
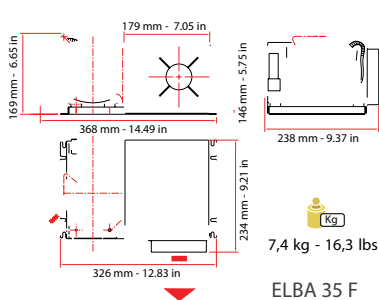
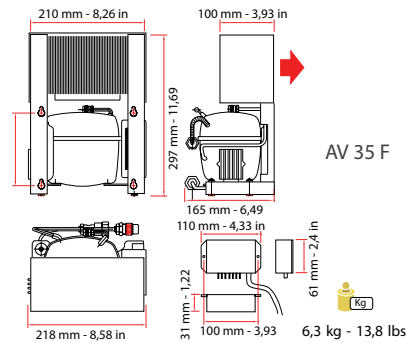
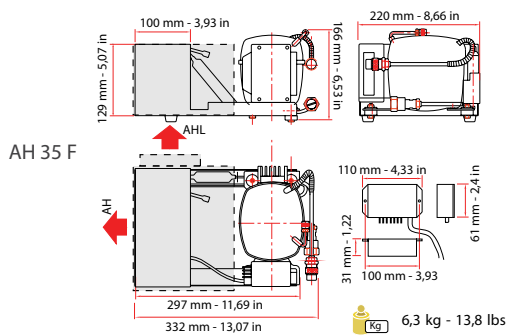
**KEEL COOLED COMPRESSORS | compressore a fuoriscafo**

	MAX CAPACITY FRIDGE (lt)	MAX CAPACITY FREEZER (lt)	CODE	RPM	CAPACITY (Btu/h)	CONSUMPTION		NET WEIGHT (kg)	GROSS WEIGHT (kg)	SIZE (WxDxH*)	REFRIGERANT
						(A)	(W)				
<b>K 35 F</b>	340	100	<b>E50345X</b>	2000	326	3,00	31	5,8	6,6	260x145x170	r134a
				2500	406	3,40	40				
				3000	471	3,90	47				
				3500	540	4,60	56				
<b>K 50</b>	380	100	<b>E51975</b>	2000	369	4,00	45	5,8	6,6	260x145x170	r134a
				2500	472	4,70	56				
				3000	560	5,70	66				
				3500	650	6,80	81				



## AIR COOLED COMPRESSORS | *compressore ad aria*

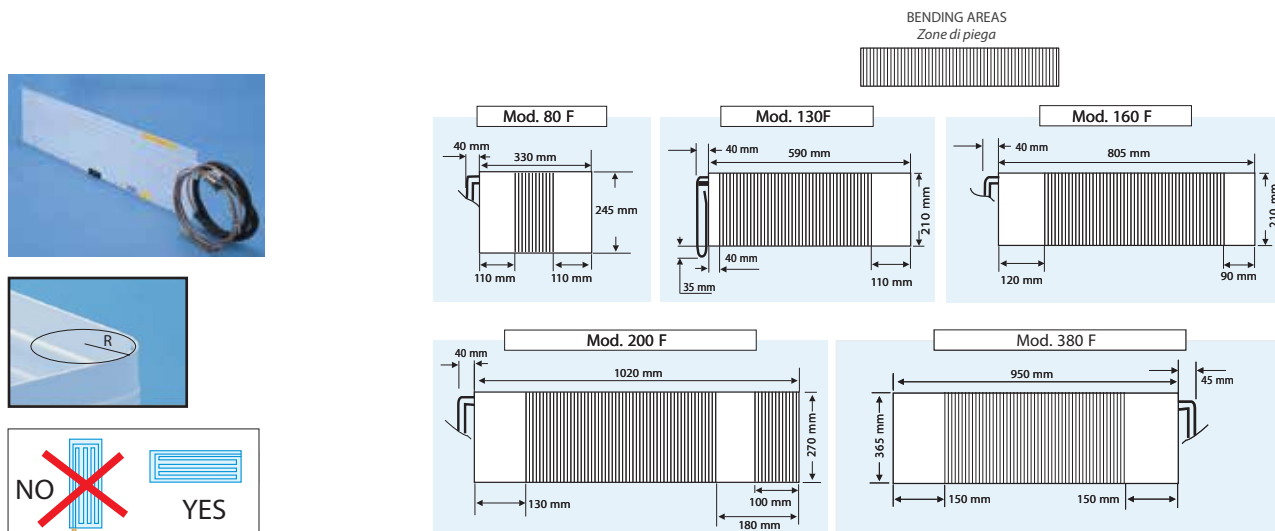
	MAX CAPACITY FRIDGE (lt)	MAX CAPACITY FREEZER (lt)	CODE	RPM	CAPACITY (Btu/h)	CONSUMPTION		NET WEIGHT (kg)	GROSS WEIGHT (kg)	SIZE (WxDxH*)	REFRIGERANT	GAS CHARGE
						(A)	(W)					
<b>MADRID 35 F</b>	100	n.a.	<b>E51380</b>	2000	225	3,40		5,80	6,60	231x128x288	r134a	80 gr
<b>PARIS 35 F</b>	100	n.a.	<b>E51135</b>	2000	225	3,40	36	6,30	6,90	230x300x168	r134a	70 gr
<b>ROMA 35 F</b>	100	n.a.	<b>E51275</b>	2000	225	3,40	41	6,20	7,00	345x210x165	r134a	70 gr
<b>FM100</b>	100	n.a.	<b>E52270</b>	2000	225	3,40	36	6,30	6,90	200x224x169	r134a	70 gr
<b>ELBA 35F</b>	200	70	<b>E51435</b>	2000	247	3,20	37	7,4	8	310x238xXXX	r134a	90 gr
				2500	280	4,10	49					
				3000	325	4,70	57					
				3500	373	5,50	66					
<b>CAPRI 35F</b>	340	80	<b>E51430</b>	2000	247	3,20	37	8,5	9,5	266x239x170	r134a	90 gr
				2500	280	4,10	49					
				3000	325	4,70	57					
				3500	373	5,50	66					
<b>FM 200</b>	200	70	<b>E52375</b>	2000	247	3,20	37	7,4	8	300x180x164	r134a	-
				2500	280	4,10	49					
				3000	325	4,70	57					
				3500	373	5,50	66					
<b>AH 35 F</b>	340	70	<b>E50035X</b>	2000	274	3,20	37	6,3	7,1	332x220x168	r134a	90 gr
				2500	311	4,00	48					
				3000	396	4,60	56					
				3500	454	5,40	65					
<b>AV 35 F</b>	340	70	<b>E50025X</b>	2000	274	3,20	37	6,3	7,1	218x165x297	r134a	90 gr
				2500	311	4,00	48					
				3000	396	4,60	56					
				3500	454	5,40	65					
<b>CAPRI 50 F</b>	340	80	<b>E52120</b>	2000	326	4,30	49	8,5	-	283x255x170	r134a	90 gr
				2500	410	5,40	64					
				3000	490	6,50	75					
				3500	565	7,50	89					



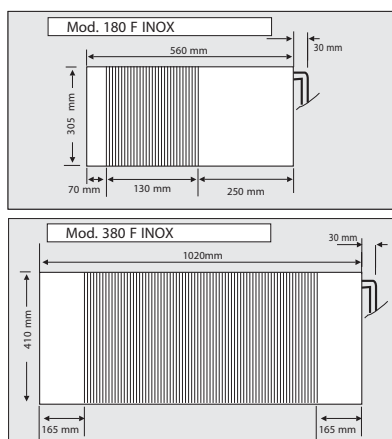
**EVAPORATOR F | evaporatore serie F**

Flat (or plate) evaporators are ideal for top loading cold boxes that will be a dedicated refrigerator or freezer as they maximise both the access and the volume available. They can be bent (to a 25mm radius) to fit around the inside of the box. Supplied with 2.8m of pre-charged, copper refrigerant pipe as standard (pipe extensions are available from 1 to 6 meters). Provided with Frigoboat self-sealing couplings.

Evaporatori stesi, ideali per frigoriferi (o freezer) a pozzetto, massimizzano la semplicità di accesso al vano e il volume disponibile. Possono essere lasciati stesi o piegati con un raggio minimo di 25mm per aderire perfettamente all'interno di un vano. Gli evaporatori sono già precaricati, con tubazioni in rame da 2.8mt di standard. Sono comunque disponibili di tubi precaricati da 1 a 6 metri). Forniti con innesti rapidi per un'installazione semplice ed elementare.



**EVAPORATOR F-INOX | evaporatore serie F-inox**



	CODE Codice	TUBE MATERIAL Materiale tubo	SERIE	MAX FRIDGE (Lt)	MAX FREEZER (Lt)	TYPE Tipo	BENDABLE Piegabile	EXPANSION Espansione	INSTALLATION Installazione	SUGGESTED RPM		SIZE Dimensioni (LxAxP)	NET WEIGHT Peso netto (Kg)	SHIPPING WEIGHT Peso lordo (kg)
										Fridge	Freezer			
<b>80F</b>	E50883	aluminium	F	80	-	flat	yes	capillar	Oriz.	200	-	330x245x5	1,1	2,5
<b>160F</b>	E52480	aluminium	F	180	70	flat	yes	capillar	Oriz.	2500	3500	805x210x5	1,4	2,4
<b>130F</b>	E50085	copper	F	160	60	flat	yes	capillar	Oriz.	2500	3000	590x210x5	1,2	2,5
<b>160F</b>	E50095	copper	F	180	70	flat	yes	capillar	Oriz.	2500	3500	805x210x5	1,4	2,4
<b>200F</b>	E50075	copper	F	240	80	flat	yes	capillar	Oriz.	3000	3500	1020x270x5	1,5	2,5
<b>380F</b>	E52225	copper	F	380	100	flat	yes	capillar	Oriz.	3500	3500	950x365x5	2,1	3,3
<b>180F inox</b>	E52105	copper	F	180	70	flat	yes	capillar	Oriz.	3000	3500	590x305x8	2,2	2,8
<b>380F inox</b>	E52185	copper	F	380	80	flat	yes	capillar	Oriz.	3500	3500	1020x410x8	3,2	3,8

## FRIGOMATIC

### EVAPORATOR B SERIE | evaporatore serie B

All Frigoboat B series evaporators can be used as a freezer compartment within a fridge or as a dedicated freezer. These freezer compartments can be mounted vertically or horizontally.

The 340B has an optional lid when used horizontally.

Supplied with 2.8m of pre-charged, copper refrigerant pipe as standard (pipe extensions are available from 1 to 6 meters).

Provided with Frigoboat self-sealing couplings.

*Tutti gli evaporatori Frigoboat della serie B sono l'ideale per vani freezer o vani frigo dedicati e possono essere installati orizzontali o verticali.*

*Gli evaporatori sono già precaricati, con tubazioni in rame da 2.8mt di standard.*

*Sono comunque disponibili di tubi precaricati da 1 a 6 metri).*

*Forniti con innesti rapidi per un'installazione semplice ed elementare.*



250 B



200 B

	CODE Codice	TUBE MATERIAL Materiale tubo	SERIE	MAX FRIDGE (Lt)	MAX FREEZER (Lt)	TYPE Tipo	BENDABLE Piegabibile	EXPANSION Espansione	INSTALLATION Installazione	SUGGESTED RPM		SIZE Dimensioni (LxAxP)	NET WEIGHT Peso netto (Kg)	SHIPPING WEIGHT Peso lordo (kg)
										Fridge	Freezer			
<b>200B</b>	E50100	copper	B	220	80	Bended	yes	capillar	Vert.	3000	3500	325x270x245	2,2	3
<b>250B</b>	E51625	copper	B	250	80	Bended	yes	capillar	Vert.	3000	3500	250x285x160	1,6	2,4
<b>340B</b>	E50105	copper	B	340	80	Bended	yes	capillar	Vert.	3500	3500	380x290x150	2,2	3

### EVAPORATOR H SERIE | evaporatore serie H

All Frigoboat H series evaporators can be used as a freezer compartment within a fridge. These freezer compartments can be mounted vertically or horizontally. They are all supplied with a lid when used horizontally. Supplied with 2.8m of pre-charged, copper refrigerant pipe as standard (pipe extensions are available from 1 to 6 meters).

Provided with Frigoboat self-sealing couplings.

*Tutti gli evaporatori Frigoboat della serie H sono l'ideale per essere utilizzati come vano freezer in un frigorifero. L'installazione può essere sia verticale che orizzontale, e sono tutti forniti di coperchio nella versione orizzontale. Gli evaporatori sono già precaricati, con tubazioni in rame da 2.8mt di standard. Sono comunque disponibili di tubi precaricati da 1 a 6 metri).*

*Forniti con innesti rapidi per un'installazione semplice ed elementare.*



130 H



160 H



200 H

	CODE Codice	TUBE MATERIAL Materiale tubo	SERIE	MAX FRIDGE (Lt)	MAX FREEZER (Lt)	TYPE Tipo	BENDABLE Piegabibile	EXPANSION Espansione	INSTALLATION Installazione	SUGGESTED RPM		SIZE Dimensioni (LxAxP)	NET WEIGHT Peso netto (Kg)	SHIPPING WEIGHT Peso lordo (kg)
										Fridge	Freezer			
<b>160H</b>	E52475	aluminium	H	200	80	ice box	no	capillar	Vert. & Oriz.	3000	3500	320x115x210	1,5	2,4
<b>130H</b>	E50065	copper	H	120	50	ice box	no	capillar	Vert. & Oriz.	2500	3000	255x70x210	1,3	1,8
<b>160H</b>	E50090	copper	H	200	80	ice box	no	capillar	Vert. & Oriz.	3000	3500	320x115x210	1,5	2,4
<b>200H</b>	E50070	copper	H	200	80	ice box	no	capillar	Vert. & Oriz.	3000	3500	360x150x270	2,2	2,9



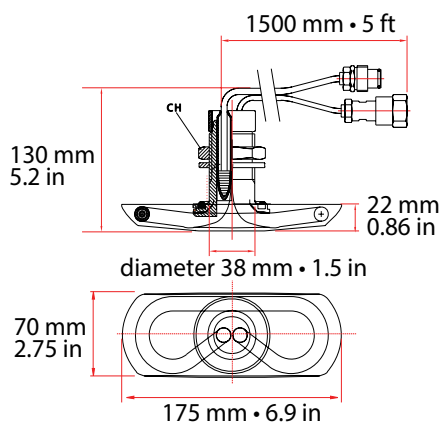
KEEL COOLERS | fuoriscafo

Frigoboat keel cooler system is the first keel cooler system invented.

The hull exchanger system has two main advantages; first, thanks to its design, it does not interfere with your sailing, and second, it used the sea water outside of the boat to cool down refrigerant, allowing an extrimly high rate of heat exchange, guaranteeing the best performances.

Even if the boat is not sailing, or when it's in tropical areas, the refrigeration system will keep working at its best.

*Il condensatore fuoriscafo Frigoboat è stato inventato da Veco per ottimizzare i consumi di bordo e ottenere la massima efficienza dal sistema Frigoboat. Lo scambiatore fuoriscafo ha due vantaggi principali; come prima cosa, grazie alla particolarità del suo design, non interferisce con la navigazione, e inoltre utilizza l'acqua di mare che circonda la barca per raffreddare il refrigerante, garantendo un alto scambio termico e le migliori performance al sistema Frigomatic.*



Code	D - thickness (mm   inch.)	Description
E50361	45 mm   1-3/4"	Keel cooler with thread fixation Scambiatore fuoriscafo con fissaggio a vite
E50361Z	45 mm   1-3/4"	Keel cooler with thread fixation with protective zinc Scambiatore fuoriscafo con fissaggio a vite e zinco di protezione
E50362	105 mm   4"	Keel cooler with long thread fixation Scambiatore fuoriscafo con fissaggio a vite lunga
E50362Z	105 mm   4"	Keel cooler with long thread fixation with protective zinc Scambiatore fuoriscafo con fissaggio a vite lunga e zinco di protezione

THERMOSTATS | termostati

A full range of mechanical or digital thermostats will allow you to set and precisely control the temperature for fridges or freezers.

*Una gamma completa di termostati Frigoboat per frigo o freezer permetto un controllo preciso della temperatura.*



DIGITAL THERMOSTAT WITH NTC  
CODE. E53355 (230V - 115V)  
CODE. E52260 (12V-24V)



FRIDGE THERMOSTAT  
CODE. E250500



FREEZER THERMOSTAT  
CODE. E250700



FRIDGE AND FREEZER THERMOSTAT  
CODE. E261300



FULL RANGE THERMOSTAT  
CODE. A020300

EXTENSIONS | prolunghe

E50255	1 meter extension / estensione da 1 mt
E50260	2 meter extension / estensione da 2 mt
E50265	3 meter extension / estensione da 3 mt
E50270	4 meter extension / estensione da 4 mt
E50275	5 meter extension / estensione da 5 mt
E50280	6 meter extension / estensione da 6 mt

A full range of extension pipes fitted with Frigoboat self sealing couplings allows to locate your Frigomatic condensing unit up to 6 meters from the evaporator.

*Una gamma completa di prolunghe, tutte dotate di innesti rapidi Frigoboat, permettono di poter installare il Frigomatic fino a 6 metri dal vano refrigerato.*

## FRIGOMATIC

### SEA WATER PUMP | *pompa acqua mare*

Self-priming pump, specifically designed for Frigomatic water cooled refrigeration systems. Minimum amperage draw (less than 1A in 12V) and rated for continuous duty, its self-priming up to 2 mt and particularly quiet.

It can be used for cooling more than one Frigomatic condensing unit, up to 3 (adding a pump interface or a pump relay).

*Pompa autoadescante a membrana, ideale per il raffreddamento di impianti frigoriferi Frigomatic. Assorbimento minimo (inferiore a 1A a 12V), è adatta al funzionamento continuo, autoadescante fino a 2 metri e particolarmente silenziosa.*

*Può essere utilizzata per il raffreddamento di più impianti Frigomatic, fino a 3 unità moto-condensanti (utilizzando l'interfaccia pompa).*

FOR FRIGOMATIC W | *Per Frigomatic serie W*



Code A092819C

### SEA WATER STRAINER | *filtro acqua mare*

The self-priming Frigomatic pump has to be equipped with a sea water strainer 1/2", that comes on a stainless steel support.

*La pompa autoadescante deve essere sempre accompagnata da un filtro acqua mare da 1/2", che viene fornito con il suo supporto in acciaio inox.*

FOR FRIGOMATIC W | *Per Frigomatic serie W*



Code M70665

### PUMP INTERFACE | *interfaccia pompa*

The Frigoboat pump interface is a very useful accessory when more Frigomatic units are connected to the same cooling pump.

*Accessorio indispensabile per il collegamento di più gruppi Frigomatic ad una sola pompa di raffreddamento.*

FOR FRIGOMATIC W | *Per Frigomatic serie W*



Code E51385

### VOLTAGE DIVIDER | *riduttore di tensione*

Voltage divider 24V/12V used to run Frigomatic units with 24V power supply. The maximum power of this device is 3A.

*Riduttore di tensione 24V/12V, necessario per il funzionamento dei Frigomatic con alimentazione a 24V. La potenza massima è di 3A.*

FOR ALL FRIGOMATIC | *Per tutti i modelli di Frigomatic*



Code E51385

### ELECTRONIC CONTROLLER | *controllo elettronico*

Electronic controller for Danfoss BD35 and BD50 compressors, incorporating the universal mains supply adaptor (230V/50-60 and 115V/50-60); when mains is available, this device automatically excludes the battery supply and runs the compressor from mains.

This device is compatible for 12V and 24V installations and includes an overload protection for the A.C. supply with a limit of 100W. For Frigomatic W units (pump cooled), the pump needs a separate power supply. The controller can be installed remotely extending the wires up to 75 cm. (2 1/2 ft).

*Controllo elettronico per compressori Danfoss BD35 e BD50; include l'alimentatore universale (230V/50-60 e 115V/50-60); quando l'alimentazione principale è disponibile il dispositivo esclude automaticamente l'alimentazione da batteria e utilizza l'alimentazione principale.*

*Compatibile per installazioni a 12V e 24V, include una protezione per l'alimentazione A.C. a 100W. Per unità Frigomatic W (raffreddamento ad acqua con pompa), l'alimentazione della pompa è separata. Il controllo elettronico può essere installato lontano dal compressore, estendendo i collegamenti fino ad un massimo di 75cm (2 1/2 ft).*

FOR ALL FRIGOMATIC | *Per tutti i modelli di Frigomatic*



Code E52530

## A.C. CONDENSING UNITS | *compressori in D.C.*

Veco code	HP	Cooling type	Refrigerant	Connection	Power supply	Capacity Fridge (-5°) (W)	Capacity Freezer (-25°) (W)	Start current LRA (A)	Run current Fridge (-5°) (A)	Run current Freezer (-25°) (A)	Connection on liquid line	Connection on suction line
RCU0017AAU*	0,17	Air cooled	R134A	Self-sealing couplings	230/1/50	277	98	5,7	1,2	1,0	Self sealing	Self sealing
RCU0017WAU*	0,17	Water cooled	R134A	Self-sealing couplings	230/1/50	346	122	5,7	1,0	0,9	Self sealing	Self sealing
RCU0050AAU*	0,50	Air cooled	R134A	Self-sealing couplings	230/1/50	746	216	12,6	2,4	1,8	Self sealing	Self sealing
RCU0050WAU*	0,50	Water cooled	R134A	Self-sealing couplings	230/1/50	933	270	12,6	4,0	2,6	Self sealing	Self sealing
RCU0050ABU*	0,50	Air cooled	R404A	Flare connections	230/1/50	1.357	513	21,3	3,7	2,6	flare (1/4" - 6)	flare (3/8" - 8)
RCU0050KBU*	0,50	Keel cooled	R404A	Flare connections	230/1/50	1.594	613	21,3	2,3	1,7	flare (1/4" - 6)	flare (3/8" - 8)
RCU0050WBU*	0,50	Water cooled	R404A	Flare connections	230/1/50	1.720	662	21,3	3,5	2,5	flare (1/4" - 6)	flare (3/8" - 8)
RCU0075AAU*	0,75	Air cooled	R134A	Self-sealing couplings	230/1/50	1.250	410	21,8	3,2	2,3	Self sealing	Self sealing
RCU0075WAU*	0,75	Water cooled	R134A	Self-sealing couplings	230/1/50	1.563	513	21,8	4,6	3,4	flare (3/8" - 8)	flare (1/2" - 10)
RCU0075KBU*	0,75	Keel cooled	R404A	Flare connections	230/1/50	1.567	558	25,6	3,1	2,2	flare (3/8" - 8)	flare (1/2" - 10)
RCU0075WBU*	0,75	Water cooled	R404A	Flare connections	230/1/50	1.719	611	25,6	4,4	3,4	flare (3/8" - 8)	flare (1/2" - 10)
RCU0075WBY*	0,75	Water cooled	R404A	Flare connections	400/3/50	1.989	780	15,0	1,8	1,4	flare (3/8" - 8)	flare (1/2" - 10)
RCU0100WBY*	1,00	Water cooled	R404A	Flare connections	400/3/50	2.704	929	10,7	1,8	1,2	flare (3/8" - 8)	flare (1/2" - 10)
RCU0100WBU*	1,00	Water cooled	R404A	Flare connections	230/1/50	2.374	866	22,0	4,3	3,0	flare (3/8" - 8)	flare (1/2" - 10)
RCU0150WBY*	1,50	Water cooled	R404A	Flare connections	400/3/50	4.029	1.422	19,2	3,1	2,0	flare (3/8" - 8)	flare (1/2" - 10)
RCU0200WBU*	2,00	Water cooled	R404A	Flare connections	230/1/50	6.153	2.137	68,0	11,4	7,4	flare (1/2" - 14)	flare (5/8" - 16)
RCU0200WBY*	2,00	Water cooled	R404A	Flare connections	400/3/50	6.078	2.111	25,0	4,2	2,9	flare (1/2" - 14)	flare (5/8" - 16)
RCU0300WBY*	3,00	Water cooled	R404A	Flare connections	400/3/50	8.252	2.866	32,0	5,5	3,8	flare (1/2" - 14)	flare (5/8" - 16)
RCU0550WBY*	5,50	Water cooled	R404A	Flare connections	400/3/50	14.789	5.136	63,0	9,3	6,1	flare (5/8" - 16)	flare (1" - 25)

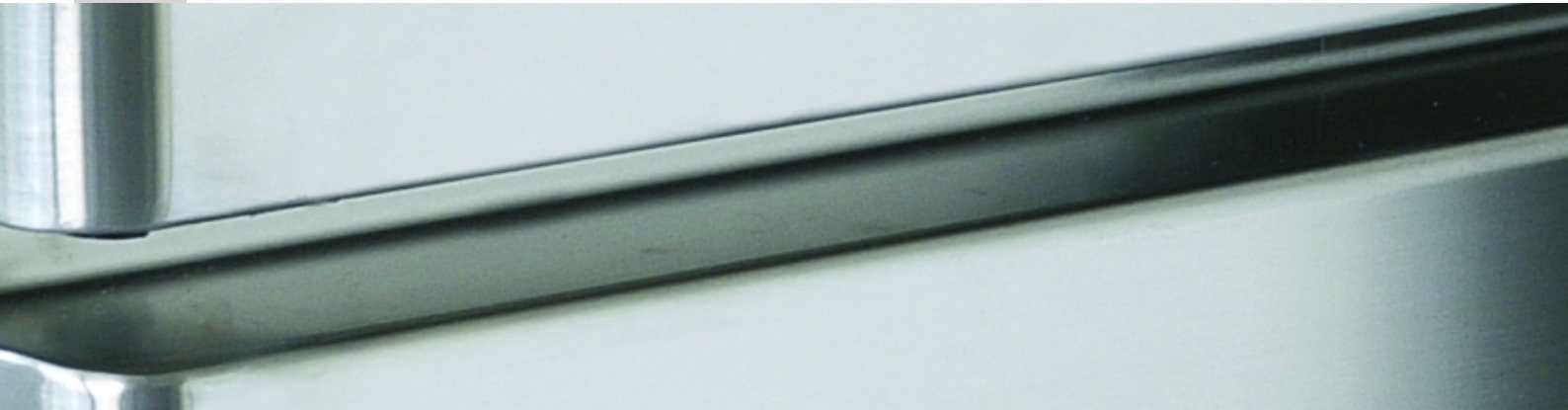
## BLOW-AIR EVAPORATORS | *evaporatori ventilati*

Veco code	Model	Mounting type	Application	Capacity (Kw)	Fan consumption (W)	Fan consumption (A)	Defrost consumption (W)	Defrost consumption (A)	Width (mm)	Dept (mm)	High (mm)	Weight (kg)	Connection IN	Connection OUT
GEEVSB101ED	EVS 101/B	ceiling	FREEZER	0,72	106	0,7	650	3,0	611	435	120	7,1	10	10
GEEVSB131ED	EVS 131/B	ceiling	FREEZER	0,89	106	0,7	680	3,1	611	435	120	7,7	1/2 SAE	16
GEEVSB181ED	EVS 181/B	ceiling	FREEZER	1,45	159	1,1	1.080	4,9	1.111	435	120	11,1	1/2 SAE	16
GEEVSB201ED	EVS 201/B	ceiling	FREEZER	1,4	106	0,7	680	3,1	611	435	170	10,7	1/2 SAE	16
GEEVSB271ED	EVS 271/B	ceiling	FREEZER	1,7	106	0,7	850	3,9	861	435	170	13,8	1/2 SAE	16
GEEVSB291ED	EVS 291/B	ceiling	FREEZER	1,77	159	1,1	1.200	5,5	1.111	435	120	12,1	1/2 SAE	16
GEEVSB391ED	EVS 391/B	ceiling	FREEZER	2,46	159	1,1	1.200	5,5	1.111	435	170	17	1/2 SAE	16
GEEVSB041ED	EVS 41/B	ceiling	FREEZER	0,37	53	0,4	480	2,2	411	435	120	4,3	10	10
GEEVSB521ED	EVS 521/B	ceiling	FREEZER	3,22	212	1,4	1.600	7,3	1.461	435	170	23	1/2 SAE	16
GEEVSB061ED	EVS 61/B	ceiling	FREEZER	0,47	53	0,4	480	2,2	411	435	120	4,9	10	10
GEEV101ED	EVS 101	ceiling	FRIDGE	0,84	106	0,7	650	3,0	611	435	120	7,1	10	10
GEEV131ED	EVS 131	ceiling	FRIDGE	1,01	106	0,7	680	3,1	611	435	120	7,7	1/2 SAE	10
GEEV181ED	EVS 181	ceiling	FRIDGE	1,7	159	1,1	1.080	4,9	1.111	435	120	11,1	1/2 SAE	16
GEEV201ED	EVS 201	ceiling	FRIDGE	1,46	106	0,7	680	3,1	611	435	170	10,7	1/2 SAE	16
GEEV271ED	EVS 271	ceiling	FRIDGE	1,73	106	0,7	850	3,9	861	435	170	13,8	1/2 SAE	16
GEEV291ED	EVS 291	ceiling	FRIDGE	2,06	159	1,1	1.200	5,5	1.111	435	120	12,1	1/2 SAE	16
GEEV391ED	EVS 391	ceiling	FRIDGE	2,52	159	1,1	1.200	5,5	1.111	435	170	17	1/2 SAE	16
GEEV041ED	EVS 41	ceiling	FRIDGE	0,43	53	0,4	480	2,2	411	435	120	4,3	10	10
GEEV521ED	EVS 521	ceiling	FRIDGE	3,29	212	1,4	1.600	7,3	1.461	435	170	23	1/2 SAE	16
GEEV061ED	EVS 61	ceiling	FRIDGE	0,53	53	0,4	480	2,2	411	435	120	4,9	10	10
GEEP100ED	EP 100	wall	FRIDGE / FREEZER	0,77	53	0,4	300	1,4	460	200	700	7,1	12,7	12,7
GEEP200ED	EP 200	wall	FRIDGE / FREEZER	1,55	106	0,7	600	2,7	810	200	700	12,1	12,7	15,875
GEEP300ED	EP 300	wall	FRIDGE / FREEZER	2,31	159	1,1	900	4,1	1.160	200	700	16,8	12,7	15,875
GEEP80ED	EP 80	wall	FRIDGE / FREEZER	0,55	53	0,4	300	1,4	460	200	700	6,4	12,7	12,7

## ACCESSORIES AND CONTROLS | *accessori e controlli*

Veco supplies also all the necessary parts for a complete system: solenoid valves, thermostatic valves, kvp valves and all the electronic controls. Please contact us directly to define the right components for your project.

Veco fornisce inoltre tutti gli accessori necessari per il circuito frigorifero: dai kit solenoide, alle valvole termostative, valvole kvp, fino ad arrivare al controllo elettronico completo. Contattaci per definire i componenti giusti per il tuo progetto.



- STAINLESS STEEL AISI 304 THROUGHOUT
- EXCELLENT INSULATION
- 180° DOOR OPENING WITH SLAM LATCH CATCH
- POLISHED STAINLESS INTERIOR
- STAINLESS STEEL BOTTLE AND CAN HOLDERS
- REMOTE COOLING UNIT TO MAXIMIZE VOLUME, REDUCE NOISES AND IMPROVE EFFICIENCY
- COSTRUITO INTERAMENTE IN ACCIAIO INOX AISI 304
- MASSIMO ISOLAMENTO
- APERTURA PORTA 180°
- RIPIANI ANTIROLLIO IN ACCIAIO INOX
- PORTABOTTIGLIE E PORTALATTINE IN ACCIAIO INOX
- COMPRESSORE REMOTO PER MAGGIORI VOLUMI, ELIMINARE I RUMORI E MIGLIORARE L'EFFICIENZA

The FRIGOBOAT MS Series are the best quality marine fridge and freezer cabinets available. A complete range of fridges, freezers and wine cellars for blue water cruisers and all other high end marine applications - nothing else comes close. The MS Series cabinets are the result of VECO's 40 years' experience in designing and producing marine refrigeration under the FRIGOBOAT brand.

Built in AISI 304 stainless steel throughout, they fit perfectly in every environment.

The elegant polished stainless steel interior is equipped with height-adjustable shelves, with optional bottle holders for the fridge version. Interiors can also be completely customized.

Every detail matters. FRIGOBOAT MS Series cabinets feature excellent door seals with compression slam latches, brushed stainless rolled edge doors, interior lightning and magnetic seals; these are just some of the characteristics that make the product one of the most innovative in the marine refrigeration field, adapting to every navigation condition.

FRIGOBOAT insist on using the maximum insulation possible to maximize efficiency and minimize power consumption. Even with the stylish Wine Cellar version insulation is maintained with insulated double glazing technology in the door.

FRIGOBOAT MS Series cabinets are designed to run with FRIGOBOAT's extensive range of air cooled, keelcooled or pumped water cooling units allowing you to select the option that gives you the maximum efficiency or optimized for the installation requirements of the boat.

*I mobili frigoriferi FRIGOBOAT MS Series, studiati appositamente per imbarcazioni, sono il risultato della grande esperienza VECO nel settore della refrigerazione marina, abbinando ad un design innovativo la qualità che da oltre quarant'anni distingue il marchio FRIGOBOAT. Una gamma completa di frigoriferi, freezer e cantine vino per soddisfare qualsiasi esigenza.*

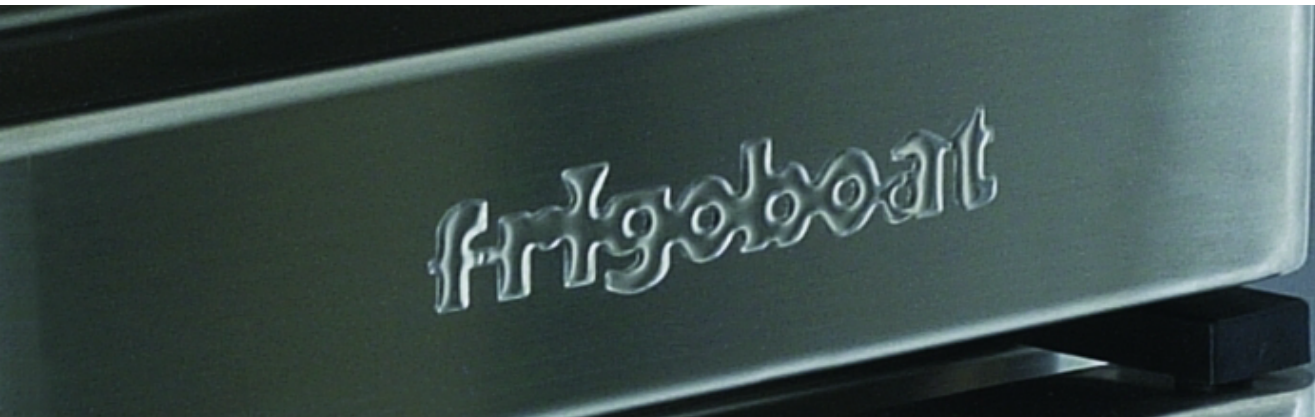
*Costruiti completamente in acciaio inox, i mobili frigoriferi FRIGOBOAT MS Series diventano un importante elemento d'arredo. Gli interni, sempre in acciaio inox, sono forniti con eleganti scaffali regolabili in altezza e portabottiglie nella versione frigo, ma possono essere completamente personalizzati grazie alle molte opzioni disponibili.*

*La cura dei dettagli, la lavorazione dei materiali con tecnologie d'avanguardia, la chiusura con maniglia, gli spigoli arrotondati, la luce interna e la guarnizione magnetica, sono solo alcune delle tante caratteristiche che contribuiscono a rendere il prodotto tra i più innovativi del settore, adattandosi perfettamente a qualsiasi condizione di navigazione.*

*Grazie all'importante isolamento in pluriuretano espanso i mobili frigoriferi FRIGOBOAT MS Series garantiscono il massimo isolamento minimizzando i consumi; anche nelle eleganti versioni FRIGOBOAT cantina vino l'isolamento viene garantito grazie ai doppi vetri della porta.*

*I mobili frigoriferi FRIGOBOAT MS Series sono progettati per essere abbinati alle diverse unità refrigeranti della linea FRIGOBOAT, sia con raffreddamento ad aria che ad acqua, per ottenere la massima efficienza del sistema adattando l'installazione alle necessità della propria imbarcazione.*





Freezer



Fridge | Freezer



Fridge with ice box



Two drawers Fridge | Freezer



Wine Cellar

	PRODUCT CODE	MODEL	ICE BOX	SIZE LXDHXH (mm)	INSULATION (mm)	SHELVES	BOOTLE HOLDERS	CAN HOLDERS	CAPACITY (lt)	NET WEIGHT (Kg)	VOLUME (Lt <sup>3</sup> )
FRIDGE	G52161*	MS 80	Yes	470 x 435 x 600	50	1	1	1	80	32	0,12
	G50761*	MS 115	Yes	480 x 485 x 840	50	3	1	1	115	39	0,20
	G50841*	MS 130	Yes	530 x 530 x 745	50	3	1	1	130	41	0,21
	G50846*	MS 160	Yes	545 x 550 x 840	50	3	1	2	160	43	0,25
	G52146*	MS 42 IN	No	380 x 362 x 510	50	1	1	0	42	26	0,07
	G52156*	MS 80 IN	No	470 x 435 x 600	50	1	1	1	80	32	0,12
	G51366*	MS 115 IN	No	480 x 485 x 840	50	3	1	1	115	39	0,20
	G51296*	MS 130 IN	No	530 x 530 x 745	50	3	1	1	130	41	0,21
	G51051*	MS 160 IN	No	545 x 550 x 840	50	3	1	2	160	43	0,25
G51611*	MS 180 IN	No	545 x 550 x 1000	50	4	1	2	180	45	0,30	

	PRODUCT CODE	MODEL	ICE BOX	SIZE LXDHXH (mm)	INSULATION (mm)	SHELVES	CAPACITY (lt)	NET WEIGHT (Kg)	VOLUME (Lt <sup>3</sup> )
FREEZER	G51370*	MS 60	No	480 x 485 x 840	80	3	60	39	0,20
	G51156*	MS 80	No	530 x 530 x 745	80	3	80	41	0,21
	G51616*	MS 90	No	545 x 550 x 680	80	2	90	42	0,21
	G51046*	MS 110	No	545 x 550 x 840	80	3	110	43	0,25

	PRODUCT CODE	MODEL	ICE BOX	SIZE LXDHXH (mm)	INSULATION (mm)	BOTTLE CAPACITY	CAPACITY (lt)	NET WEIGHT (Kg)	VOLUME (Lt <sup>3</sup> )
WINE CELLAR	G51271*	MSC 115	No	480 x 485 x 840	50	18	115	43	0,20
	G51276*	MSC 130	No	530 x 530 x 745	80	20	130	45	0,21
	G51281*	MSC 160	No	545 x 550 x 840	80	23	160	48	0,25

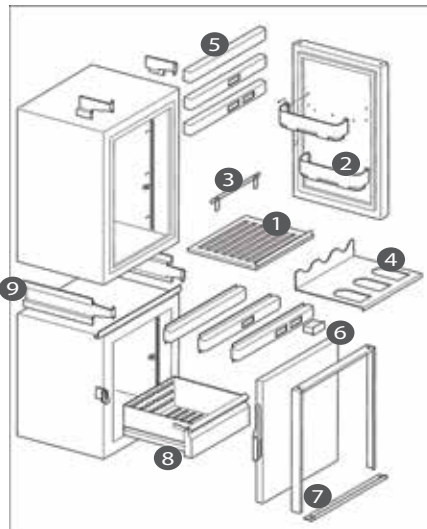
	PRODUCT CODE	MODEL	ICE BOX	SIZE LXDHXH (mm)
FRIDGE AND FREEZER DRAWER	G60031*	FRIDGE MS 115 2D	480 x 435 x 940	480 x 485 x 864
	G60036*	FRIDGE MS 130 2D	530 x 480 x 745	530 x 530 x 769
	G 60041*	FRIDGE MS 160 2D	545 x 500 x 840	545 x 550 x 864
	G60046*	FREEZER MS 60 2D	480 x 435 x 840	480 x 485 x 864
	G60051*	FREEZER MS 80 2D	530 x 480 x 745	530 x 530 x 769
	G60056*	FREEZER MS 90 2D	545 x 500 x 680	545 x 550 x 704
G60061*	FREEZER MS 110 2D	545 x 500 x 840	545 x 550 x 864	

Feet	25 mm
Handle	25 mm
Hinge	10 mm
Space required on the back	30mm
Fitting Frame	25 mm

\* 12=12V DC, 24=24V DC, U=230V/1/50HZ

Door size is included in the cabinet, door handles are excluded from cabinet size.

Please contact our technical department for a detailed drawing of cabinets with exact quotes.



OPTION AND EXTRAS

- 1 Additional height adjustable stainless steel shelves
- 2 Additional bottle and can holders
- 3 Shelf fiddles
- 4 Wine shelves
- 5 Thermostat stainless steel support
- 6 Thermostat displays
- 7 Wood panel surround
- 8 Internal drawers
- 9 Solution for two modules mounting
- 10 Stainless steel AISI 316



paneled door



two module solution

ACCESSORIES | accessori

SHELVES | griglie

CODE	CABINET
G51400A	MS 115 Lt
G51400B	MS 130 Lt
	MS 160 180 Lt
G51400D	MS 80 90 Lt
G51400E	MS 110 Lt

BOTTLE RACK SHELVES | ripiani portabottiglie

CODE	CABINET	BOTTLE NR.
G51260	MS 115	3
G51265	MS 115	3
G51250	MS 130	4
G51290	MS 160	4

INTERNAL DRAWERS | cassetti interni

CODE	CABINET	HEIGHT
G51620	Freezer 90 110 Lt	125mm
G51685	Freezer 90 110 Lt	200mm
G52165	Fridge 130 Lt	125mm
G52200	Fridge 130 Lt	200mm
G52125	Fridge 160 180 Lt	125mm
G52130	Fridge 160 180 Lt	200mm
G56400	Freezer 80 Lt	125mm
G56405	Freezer 80 Lt	200mm

DOORS PANNELLING KIT | kit pannellatura

CODE	CABINET
G53335	Ms 80
G52495	Fridge ms115   freezer ms60
G52490	Fridge ms130   freezer ms80
G52510	Freezer ms 90
G52500	fridge ms160   freezer ms110
G52505	Fridge ms 180

THERMOSTAT HOLDER, RISERS AND SPACERS | frontalini, portatermostati e distanziali

CODE	CABINET
G51795	Top, 1 thermostat   <i>Supporto superiore 1 termostato</i>
G51735	Top, 2 thermostats   <i>Supporto superiore 2 termostati</i>
G51765	Intermediate, no thermostat   <i>Supporto intermedio senza termostati</i>
G51790	Intermediate, 1 thermostat   <i>Supporto intermedio 1 termostato</i>
G51720	Intermediate, 2 thermostats   <i>Supporto intermedio 2 termostati</i>
G51725	Spacer and intermediate panel bracket   <i>Distanziali e supporti intermedi</i>
G51730	Top panel bracket   <i>supporti superiori</i>

TRIM KITS | kit cornici

Code	Cabinet
G52660	Ms180
G50955	Fridge ms115 – freezer ms 60
G50960	Fridge ms130 – freezer ms 80
G50965	Fridge ms160 – freezer ms 110



Glass door



Wine shelves



Paneling kit



Shelves



Spacer and mounting kits



internal drawers

The Frigoboat ice maker serie, completely in stainless steel, it's ideal for under counter installations; the crystal clear and compact ice cube is perfect for cooling drinks and bottles, with size Ø 27x32 mm.

- Spray system
- Stainless steel (AISI 304)
- Air cooled, water cooled or keel cooled
- Air cooled with front ventilation on demand
- Automatic production cycle and built-in cleaning system

La gamma dei fabbricatori di ghiaccio Frigoboat, completamente in acciaio inox, è ideale per applicazioni sottobanco; il cubetto di ghiaccio è ideale per il raffreddamento di bevande e bottiglie, con dimensioni Ø 27x32 mm, cristallino e compatto.

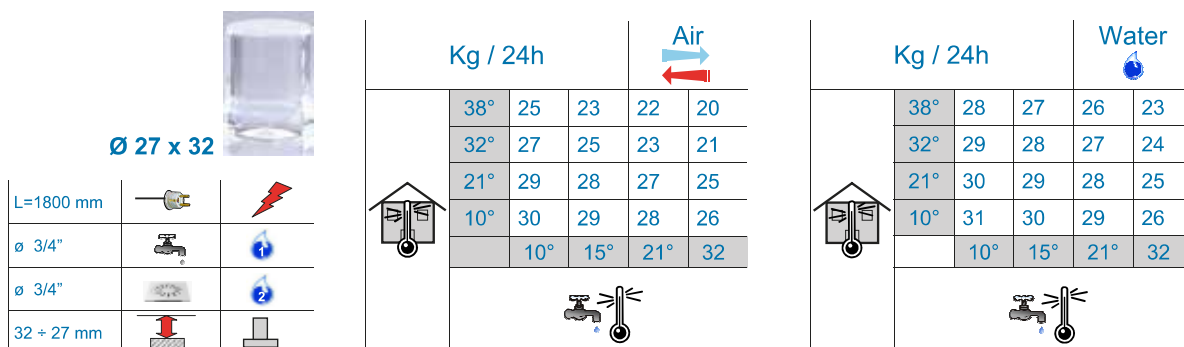
- Sistema a spruzzo
- Acciaio inox (AISI 304)
- Raffreddamento ad aria, ad acqua o a fuoriscafo
- Opzionale, per i raffreddati ad aria, la circolazione frontale per l'incasso
- Ciclo di produzione automatico e sistema di lavaggio incorporato



CODE   Codice	Ice Maker Frigoboat 24	Ice Maker Frigoboat 30
COOLING TYPE   Raffreddamento	L226AU - Air cooling   aria L226WU - water pump   acqua	L3111AU - Air cooling   aria L3111WU - water pump   acqua
CAPACITY   Capacità	24 kg/24h (52Lb/24h)	30 kg   24 h
ICE CUBE NR.   nr.cubetti (Nr.)	1333/24 h*	1660   24 h
CONSUMPTION   Consumi (W)	350	420
CONSUMPTION   Consumi (A)	2,2	2,5
REFRIGERANT   Refrigerante	R290	R290
ICE CUBE BIN   Contenitore cubetti (Kg)	6	11
ICE CUBE SIZE   Dimensione cubetto (mm)	27x32	27x32
AMBIENT TEMPERATURE   Temperatura ambiente (°C)	min 10 - max 40	min 10 - max 40
WATER CONNECTIONS   Entrata acqua	3/4"	3/4"
WATER PRESSURE   Pressione dell'acqua (Bar)	min 1 - max 6	min 1 - max 6
WATER TEMPERATURE   Temperatura dell'acqua (°C)	min 5 - max 35	min 5 - max 35
WATER DISCHARGE   Scarico acqua (lt/hr)	min 5 - max 10 lt/hr	min 5 - max 12 lt/hr
SHIPPING VOLUME   Volume (M3)	0,15	0,20
SIZE   dimensioni WxDXH (mm)	345x460x588	417x531x654
NET WEIGHT   peso netto (Kg)	32	39
SHIPPING WEIGHT   peso lordo (Kg)	36	43

FOR WATER COOLED VERSION | Per modelli raffreddati ad acqua di mare:

SW TEMPERATURE   Temperatura acqua mare (°C)	min 10 - max 35	min 10 - max 35
--	-----------------	-----------------





From 1971.

Design and production of custom refrigeration solutions for yachts and superyachts.

Our experience in the marine environment, together with quality, flexibility and efficiency, makes our solutions the best available in the market.

Over 35 years of experience dedicated to our clients.

CUSTOM FRIDGES, FREEZERS, WINE CELLARS AND COLD ROOMS.  
ANY SIZE, ANY SPACE, FOR A UNIQUE SOLUTION.

Frigoboat superyacht solutions combine a unique design, all the functionalities expected from a professional kitchen and the style and quality required from a superyacht.

Our refrigeration solutions are specifically designed for the marine; both our air cooled and water cooled systems guarantee the maximum flexibility, energy efficiency and the maximum storage space available.

- STAINLESS STEEL AISI 304 (OR 316)
- CUSTOMIZED INTERIORS
- LED LIGHTING
- SEPARATE TEMPERATURE CONTROLS
- BACKUP CIRCUITS AND SYSTEMS
- HEATED DOOR SEALS
- PAINTED FINISHES
- GLASS DOOR OPTION

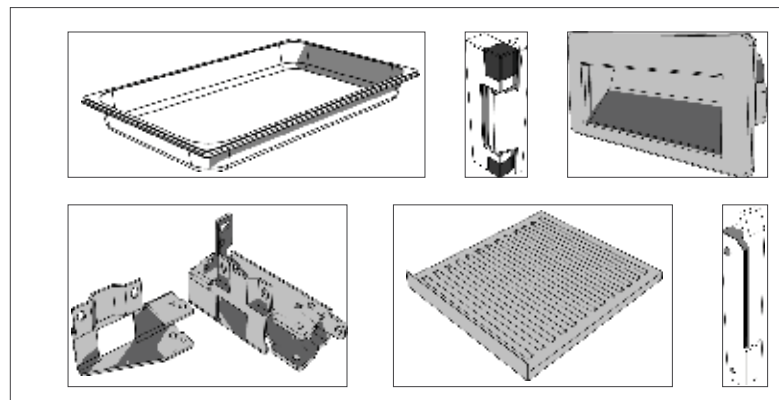
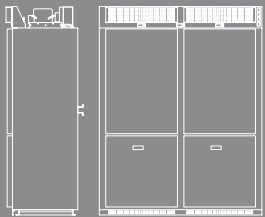
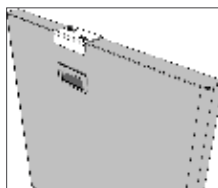
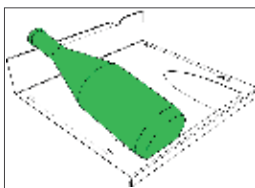
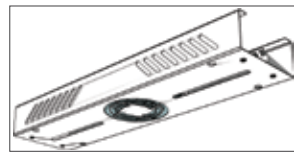
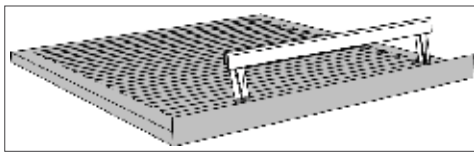
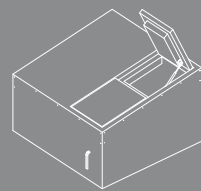
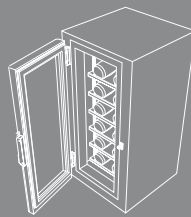
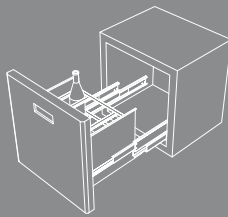
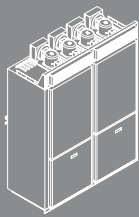


photo courtesy of Southerly





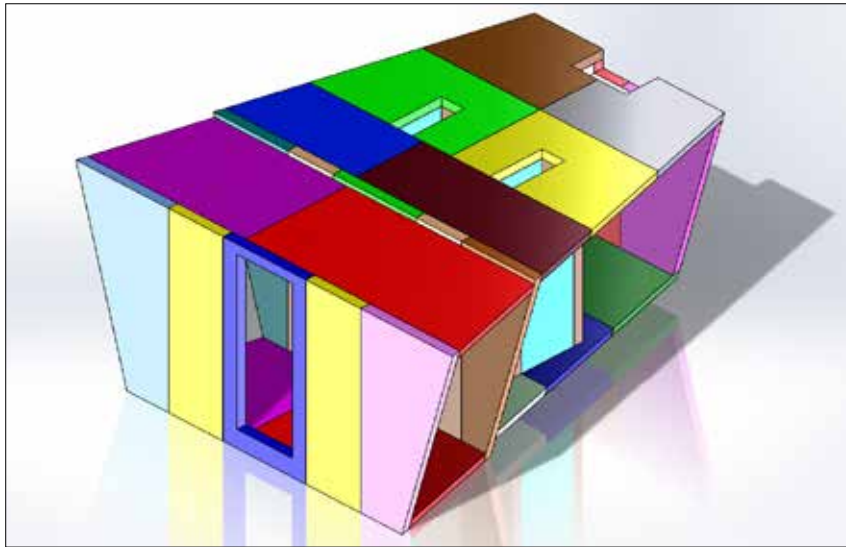
FROM  
YOUR IDEA  
TO CUSTOM  
PROJECTS





**FRIGOBOAT COLD ROOMS**

*Celle frigorifere Frigoboat*



Custom stainless steel walkable cold rooms that can fit any kind of space. Frigoboat cold rooms provide the best solution for high volumes of food storage with accurate food preservation and temperature control. A custom project around your needs.

*Su misura, calpestabili e per ogni tipologia di spazio.*

*Le celle frigorifere Frigoboat sono la miglior soluzione per grandi quantitativi di cibo da conservare ad una temperatura controllata.*

*Un progetto personalizzato al 100%.*



angoli arrotondati interni /  
inside rounded corners

incastro maschio-femmina /  
male-female nesting

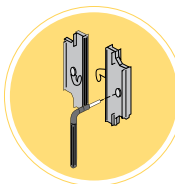
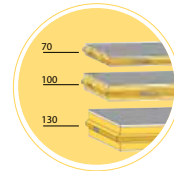
rivestimento pannelli / panels finishing

- Lamiera zincoplastificata spessore 6/10 mm + PVC bianco atossico spessore 120 micron, certificata per uso alimentare.  
*Galvanized sheet steel with plastic coating in rigid white PVC 120 micron thick non toxic.*
- Acciaio inox 18/10 AISI304 satinato opaco.  
*AISI304 18/10 stainless steel scotch bright / dull.*
- Lamiera zincoplastificata, colore a richiesta.  
*Galvanized sheet steel with plastic coating in different colors.*



spessori / thicknesses

- Standard 70-100
- Standard 70-100
- Su misura 70-100-130-a richiesta  
*Custom 70-100-130-on demand*



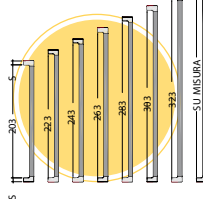
unione con ganci  
eccentrici a doppio  
effetto / connection  
with dual effect  
cam locks

isolamento / insulation

- Poliuretano espanso ad alta densità 40-42 kg/m<sup>3</sup>, auto-estinguente secondo la norma ISO 3582, privo di CFC.  
*High density polyurethane foam 40-42 kg/m<sup>3</sup>, fire retarding according ISO 3582, CFC free*
- Coefficiente di trasmissione K per spessore 70 mm 0,30 W/m<sup>2</sup>°K, per spessore 100 mm 0,21 W/m<sup>2</sup>°K.  
*Transfer coefficient k thicknesses 70 mm 0,30 w/m<sup>2</sup>°k thicknesses 100 mm 0,21 w/m<sup>2</sup>°k.*
- Coefficiente di conducibilità termica 0,021 W/m<sup>2</sup>°K.  
*Thermal conductivity coefficient Lambda 0,021w/m<sup>2</sup>°k.*
- Resistenza alla compressione 1,5-2 Kg/cm<sup>2</sup>.  
*Compression resistance 1.5 - 2 kg/cm<sup>2</sup>*

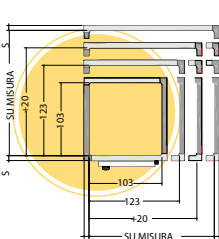
altezze / heights

Esterna = interna + 25



larghezza profondità /  
length width

Esterna = interna + 25



pavimento / floor

- Senza pavimento con fornitura di profilo sanitario "U" in PVC tondo per il fissaggio delle pareti cella al pavimento di appoggio.  
*Without floor is supplied with rounded PVC.*
- Lamiera zincoplastificata grigia antiscivolo spessore 7/10 mm.  
*Galvanized steel 7/10 mm thick with non-slip grey plastic coating walk-in static load 2000 kg/m<sup>2</sup>*
- Acciaio inox 18/10 AISI304 bugnato antiscivolo spessore 6/10 mm, pedonabile, portata statica 2000 kg/m<sup>2</sup>.  
*AISI304 18/10 stainless steel no-slip punch thick 6/10 mm walk-in static load 2000 kg/m<sup>2</sup>.*
- Carrellabile 250 kg con rinforzo in multistrato fenolico spessore 12 mm.  
*Suitable for trolley 250 kg reinforced with 12 mm fenolic multistratified wood.*
- Carrellabile 1000 kg con rinforzo in multistrato fenolico spessore 12 mm e travetti di ripartizione carico, copertura in alluminio mandorlato spessore 3 mm.  
*Suitable for trolley 1000 kg reinforced with 12 mm fenolic multistratified wood, wood beams support 3 mm aluminium sheet cover.*





The general sales and warranty conditions for Veco S.p.A. products can be found on our website [www.veco.net](http://www.veco.net).

All data in this catalogue may be subject to change without any prior notice; for more detailed information contact Veco S.p.A.

All photos, texts, drawings and tables have been designed by Veco S.p.A. that retains the intellectual property rights; the use of materials contained in the catalogue, in any form, is protected by Italian and International copyright laws.

*Le condizioni generali di vendita e garanzia dei prodotti Veco S.p.A. sono riportate sul nostro sito web [www.veco.net](http://www.veco.net).*

*Tutti i dati presenti in questo catalogo sono da intendersi puramente indicativi e possono essere soggetti a variazioni senza preavviso; per informazioni più dettagliate sui prodotti vi preghiamo di contattare Veco S.p.A.*

*Tutte le fotografie, i testi, i disegni e le tabelle tecniche sono stati concepiti da Veco S.p.A. che ne conserva il diritto intellettuale; l'utilizzo di materiali in qualsiasi forma contenuti nel catalogo è tutelato dalle leggi italiane e internazionali sul diritto d'autore.*

VECO S.p.A.  
via General Cantore, 6 20833 Giussano MB Italy  
phone: +39 0362 35321 | fax +39 0362 852995 | e-mail [info@veco.net](mailto:info@veco.net) | web: [www.veco.net](http://www.veco.net)

