

# LEWMAR®

A Lippert Components Company



Marine Equipment Guide

[www.lewmar.com](http://www.lewmar.com)



When Len Lewery started making Tufnol dinghy fittings back in 1946, not even his inventive mind could have foreseen that his small business would develop to become one of the leading marine equipment manufacturers in the world.

John Burton acquired Lewmar and embarked on a 20-year career, turning the company into a world leader in modern yacht equipment. Lewmar attacked the high-technology world of America's Cup racing, supplying the first AC winch package to Korura V in c.1966/68.

Through a series of acquisitions and mergers in the latter decades of the twentieth century, the Lewmar Range evolved to include rigging, windlass, steering, hatch and portlight. Innovations included the Wavegrip Jaw, which won the battle for the self-tailing winch market. Lewmar's distribution extended around the globe, and the expertise and success of the company won recognition with the attainment of three Queen's Awards.

Today Lewmar has transformed beyond recognition from the small company established by Len Lewery and Leslie Marsh in 1950. Yet the spirit of innovation and engineering excellence has remained constant. Today, Lewmar is the premier marine equipment supplier, designing, manufacturing, and distributing innovative, high-quality control solutions worldwide.

Manufacturing is located at two sites in the United Kingdom with sales offices in Europe and USA and a worldwide network of agents and distributors. Recent investments in sophisticated, state-of-the-art manufacturing equipment over the last few years has been undertaken to enable Lewmar to offer consistently the highest levels of quality in the industry.



With a portfolio of windlass, anchors, thrusters, hatches and portlights, glass & glazing, winches, hydraulics, hardware and steering systems, to suit every boat from the smallest day fisher to largest mega-yacht, Lewmar can supply a complete solution whatever your project and requirements.

Quality remains at the heart of everything we do. In these days of ever increasing offshore sourcing, this is just one sign of our total commitment to providing superior products to all our customers.

# LEWMAR®

## UK & International Distribution

Southmoor Lane  
Havant  
Hampshire  
PO9 1JJ  
UK

Tel: +44 (0)23 9247 1841  
Email: [info@lewmarm.com](mailto:info@lewmarm.com)  
Tech Support: [techsupport@lewmarm.com](mailto:techsupport@lewmarm.com)

[www.lewmarm.com](http://www.lewmarm.com)

## USA

351 New Whitfield Street  
Guilford, CT  
06437  
USA

Tel: +1 203 458 6200  
Email: [info@lewmarm.com](mailto:info@lewmarm.com)  
Tech Support: [ustechsupport@lewmarm.com](mailto:ustechsupport@lewmarm.com)

A Lippert Components Company 



## 1. Windlasses

Pages 4 - 78



## 2. Anchoring

Pages 79 - 100



## 3. Thrusters

Pages 101 - 130



## 4. Hatches & Portlights

Pages 131 - 187



## 5. Glass

Pages 188 - 212



## 6. Winches

Pages 213 - 268



## 7. Hydraulics

Pages 269 - 282



## 8. Hardware

Pages 283 - 354



## 9. Steering

Pages 355 - 395





## I. Windlasses



Since acquiring Simpson Lawrence many years ago, Lewmar has built a wealth of design and engineering knowledge and experience in anchoring systems. With ever-smaller fitting anchor winches, Lewmar has a wide product offering for boats between 18ft – 250ft. Using hard wearing, corrosion resistant materials on deck, coupled with powerful, under-deck motor solutions, our latest windlass designs focus on ease of use and reliability.

## The Lewmar Windlass Range



### Page 9 VX Series

- New generation of vertical windlasses
- Utilises patented hybrid polymer gypsy
- Available in horizontal or in-line motor-gearbox configurations



### Page 20 CPX Series

- Alloy construction provides strength in a lightweight format
- Design based on proven V Series



### Page 24 V Series

- Flagship vertical windlass range
- Stainless Steel construction
- For boats up to 240ft



### Page 40 HXI Windlass

- New generation horizontal windlass
- Featuring patented hybrid polymer gypsy
- Powerful gearbox provides superior performance



### Page 42 Pro-Series Windlass

- Stainless body provides looks and strength
- Available with freefall attachment
- Small footprint saves space



### Page 45 H Series

- Painted alloy body
- Powerful motor-gearbox
- Available in gypsy only, or gypsy-drum configurations



### Page 46 C Series Capstan

- Stainless Steel construction complements V Series windlass
- Sleek and unobtrusive, it blends well into the stern area



### Page 48 Captive Reel Windlass

- Innovative design provides discreet line storage solution
- Designed for rode only



### Page 49 Stern Windlass

- Rode windlass based on proven freefall design
- Designed to be hidden within the transom for bow-to mooring



### Page 50 Tender Garage Winch

- Drum-only design for taking in and storing tender retrieval line
- Elegant solution for installation in tender garage

# I. Windlasses

Whether you own a small fishing boat or a 160ft cruiser, Lewmar has a windlass designed to fit your exact needs. Integral to the designs are high-quality stainless steel components, providing longevity and reliability. Both our vertical and horizontal designs are sleek and attractive to complement your boat.

## Vertical Windlass

BOAT LENGTH OVERALL

Model	6 M 20 FT	9.2 M 30 FT	12.2 M 40 FT	15.2 M 50 FT	18.3 M 60 FT	21.3 M 70 FT	24.4 M 80 FT
VX1 300W	[Shaded bar]						
VX1 500W	[Shaded bar]						
VX1L 500W	[Shaded bar]						
VX1L 800W	[Shaded bar]						
VX2	[Shaded bar]						
VX2+	[Shaded bar]						
VX3	[Shaded bar]						
V700	[Shaded bar]						
CPX0-500W	[Shaded bar]						
CPX0-700W	[Shaded bar]						
V1/CPX1	[Shaded bar]						
V2/CPX2	[Shaded bar]						
V3/CPX3	[Shaded bar]						
V4/CPX4	[Shaded bar]						
V5	[Shaded bar]						
V6	[Shaded bar]						

## Large Vertical Windlass

Model	19.8 M 65 FT	22.9 M 75 FT	25.9 M 85 FT	29 M 95 FT	32.1 M 105 FT	35.1 M 115 FT	38.2 M 125 FT	41.2 M 135 FT	44.3 M 145 FT	47.2 M 155 FT	50.3 M 165 FT	50.3 M 175 FT	50.3 M 185 FT	50.3 M 195 FT	50.3 M 205 FT	50.3 M 215 FT	50.3 M 225 FT	50.3 M 235 FT	50.3 M 245 FT
V8 2500W	[Shaded bar]																		
V8 Hi-Power	[Shaded bar]																		
V9	[Shaded bar]																		
V10	[Shaded bar]																		
V12	[Shaded bar]																		
V14	[Shaded bar]																		
V16	[Shaded bar]																		

## Horizontal Windlass

Model	6 M 20 FT	9.2 M 30 FT	12.2 M 40 FT	15.2 M 50 FT	18.3 M 60 FT	21.3 M 70 FT	24.4 M 80 FT
HX1 300W	[Shaded bar]						
HX1 800W	[Shaded bar]						
RX2	[Shaded bar]						
RX2+	[Shaded bar]						
RX3	[Shaded bar]						
Pro-Sport 550	[Shaded bar]						
Pro-Series/Fish 700	[Shaded bar]						
Pro-Series/Fish 1000	[Shaded bar]						
H2	[Shaded bar]						
H3	[Shaded bar]						
CRW400	[Shaded bar]						
S900 Stern Windlass	[Shaded bar]						
S2000 Stern Windlass	[Shaded bar]						

Many parameters have to be taken into account when selecting a windlass, such as displacement, windage, anchor weight etc. In the above chart the boat length corresponds to a vessel with average displacement. If your vessel is of heavy displacement, please consider using a larger windlass model. Lighter shading represents the upper limit of the model. If in doubt, move up a model.

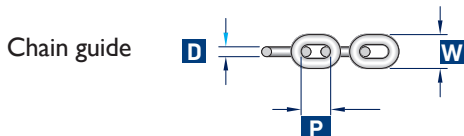

		6 MM DIN 766	6 MM ISO 4565	1/4" ACCO ISO 643 (64)	7MM DIN 766	1/4" ACCO BBB (3B)	8MM DIN 766	8MM ISO 4565	5/16" ACCO ISO 643 (64)	LEWMAR 9.5MM G40	3/8" CAMBELL S4	10MM ISO 4565	3/8" CAMPELL S3	10MM DIN 766	3/8" ACCO ISO 643 (64)	11MM SHORT LINK	11MM DIN 766	7/16" ACCO ISO 643 (64)	LEWMAR 12MM G30/G40 12MM SHORT LINK	13MM DIN 766	1/2" ACCO ISO 643 (64)	LEWMAR 14MM G30/G40 14 MM SHORT LINK	14MM DIN 766	14MM STUDLINK	16MM SHORT LINK	16MM DIN 766
<b>D</b>	MM	6	6	7	7	7.14	8	8	8.4	9.5	10	10	10	10	10	11	11	11.8	12	13	13.2	14	14	14	16	16
	INCH	0.236	0.236	0.276	0.276	0.281	0.315	0.315	0.329	0.374	0.39	0.394	0.37	0.394	0.394	0.433	0.433	0.464	0.472	0.512	0.520	0.551	0.551	0.551	0.630	0.630
<b>P</b>	MM	18.5	18	21.3	22	22.1	24	24	26.2	31.5	29	30	35	28	31	33	31	35.5	36	36	40.4	42	41	56	48	45
	INCH	0.728	0.709	0.840	0.866	0.870	0.945	0.945	1.030	1.240	1.15	1.181	1.36	1.102	1.220	1.299	1.22	1.4	1.417	1.417	1.591	1.654	1.614	2.205	1.890	1.772
<b>W</b>	MM	20.4	21.6	24.4	23.8	25.2	27.2	28.8	29.7	31.6	35	36	34	36	35	39	40	40.1	40.5	47	45.7	49	50	50.4	56	58
	INCH	0.803	0.85	0.962	0.937	0.992	1.07	1.134	1.168	1.244	1.3	1.417	1.31	1.417	1.378	1.535	1.575	1.578	1.594	1.850	1.799	1.929	1.969	1.984	2.205	2.283

## How to choose the right windlass for your boat

There are three main considerations when selecting the correct windlass for your boat:

### 1 What size windlass would best suit my boat?

Use our windlass selection chart, found on page 6/7, to determine the general size of the windlass to be fitted to your boat by using length and displacement.

### 2 How long is the anchor rode I wish to use, and will the windlass put the entire rode into my locker?

Examine the depth of the anchor locker to determine the fall that is available.

The fall is the vertical distance between the top of the anchor locker and the top of the anchor rode when the entire rode is completely stored inside.

The windlass is a retrieval device. The windlass retrieves the anchor and rode.

The windlass does not stow the rode inside the anchor locker; gravity stows the rode.

You must know how much rode will fit into your locker by gravity. There has to be a free and clear area under the hawse pipe for the incoming rode. Otherwise, you will have to comb the rode back, keeping a clear and free space under the hawse pipe while retrieving the anchor.

#### Vertical Windlass

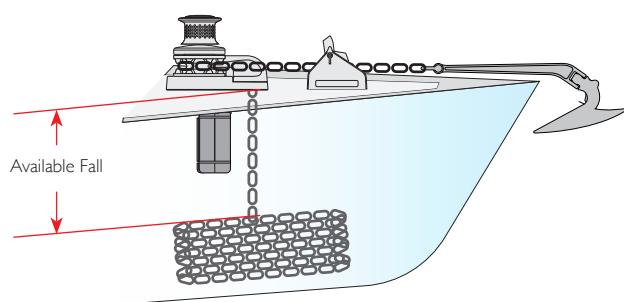

#### Vertical Windlass Key Features

- More of the unit is hidden below deck
- Suitable for large anchor lockers
- Anchor rode makes a 180° wrap around the gypsy providing more security
- Minimum fall of 406mm (18") is recommended in order to have enough gravity to pull the rode down into the locker

#### Note

The windlasses do not stow the anchor rode in the anchor locker. Gravity stows the rode in the anchor locker.

From time to time the pile of rode may have to be evacuated from under the windlasses hawse pipe entrance to make room for the remaining rode.

#### Windlass and anchor operation basic safety

##### Always

- Always tie off anchor rode to a strong point while at anchor
- Always secure anchor rode/anchor when underway
- Always look before deploying your anchor
- Always motor up to anchor while retrieving
- Always shut off circuit breaker when working on windlass
- Always shut off circuit breaker when windlass is not in use
- Always read the manual and follow safety instructions and warnings.

A windlass is not a high-load bearing device. When at anchor your rode should be secured to a chain stopper, a cleat or other mooring point on the bow.

### 3 How much pulling power should my windlass have?

Having selected a vertical or horizontal windlass and determined the size required using the chart on page 6, you can cross-check by using the following formula:

$$\text{Total weight of ground tackle (anchor and rode) } \times 4^{**} = \text{Pulling power required by the windlass}$$

\*\* Use x4 for all Horizontal windlass and Vertical windlass up to V5

\*\* Use x2 for V6 Vertical Windlass and above

Working Load, designed to allow prolonged anchor laying and retrieving

Please note this is an indication only. If in doubt please contact your Lewmar representative.

#### Horizontal Windlass

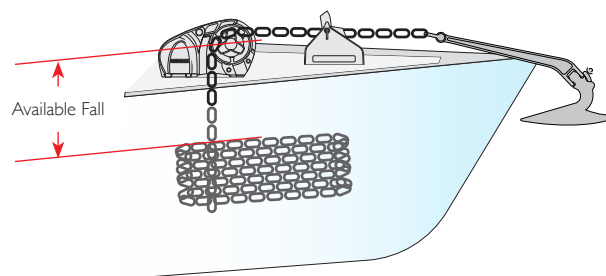

#### Horizontal Windlass Key Features

- Most of the windlass unit is on the deck
- Easy installation
- Good for boats with small anchor lockers
- Anchor rode enters the gypsy, makes a 90° turn and feeds into the anchor locker
- Minimum fall of 304mm (12") is recommended in order to have enough gravity to pull the rode down into the locker

##### Never

- Never allow your windlass to hold the boat while at anchor
- Never use your windlass to pull or tow boat
- Never use your windlass to lift a person
- Never stick fingers in or around gypsy while operating
- Never allow loose clothing and hair to come close to windlass when operating

# I. Windlasses

## Windlass & Anchoring Know-How

Please see your owner's manual for complete installation diagrams.

### Vertical Windlass

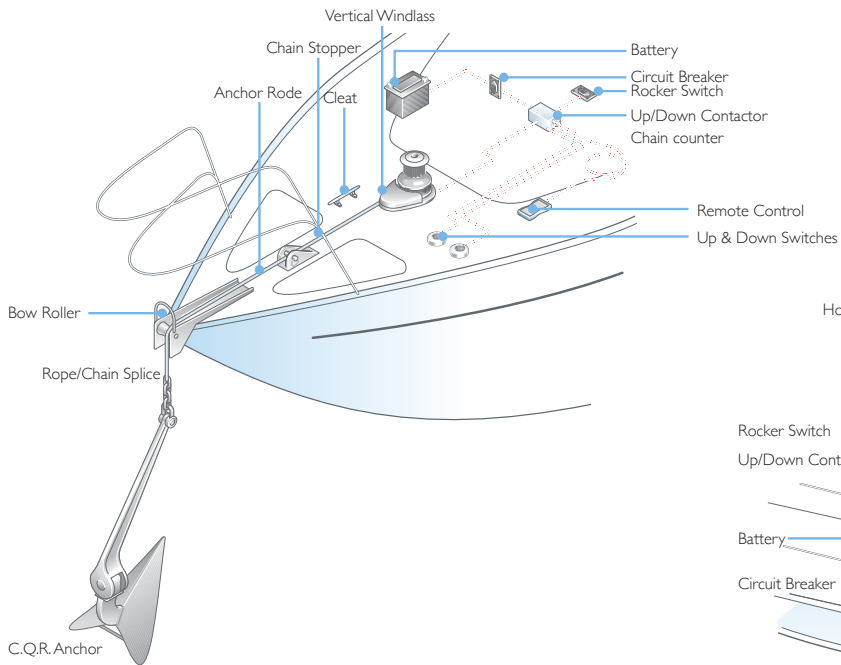

### Horizontal Windlass

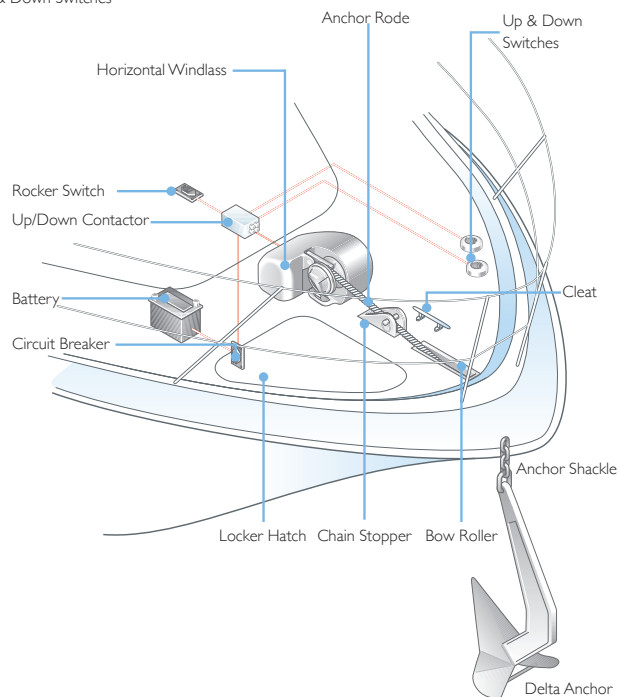

## Specify your Windlass

### 1 Deck Unit

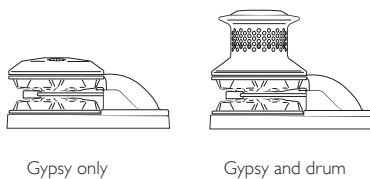

### 2 Motor Gearbox

- Electric/hydraulic specification

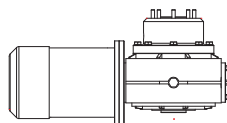

### 3 Gypsy

- Chain specification

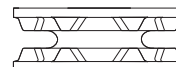

## Switch kit and accessories

### 4 Circuit breaker

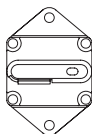

### 5 Contactor/ control box

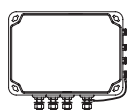

### 6 Switch and accessories

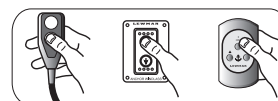

### 7 Optional accessories

- A range of optional accessories are available for each model. Refer to the specific windlass model pages.



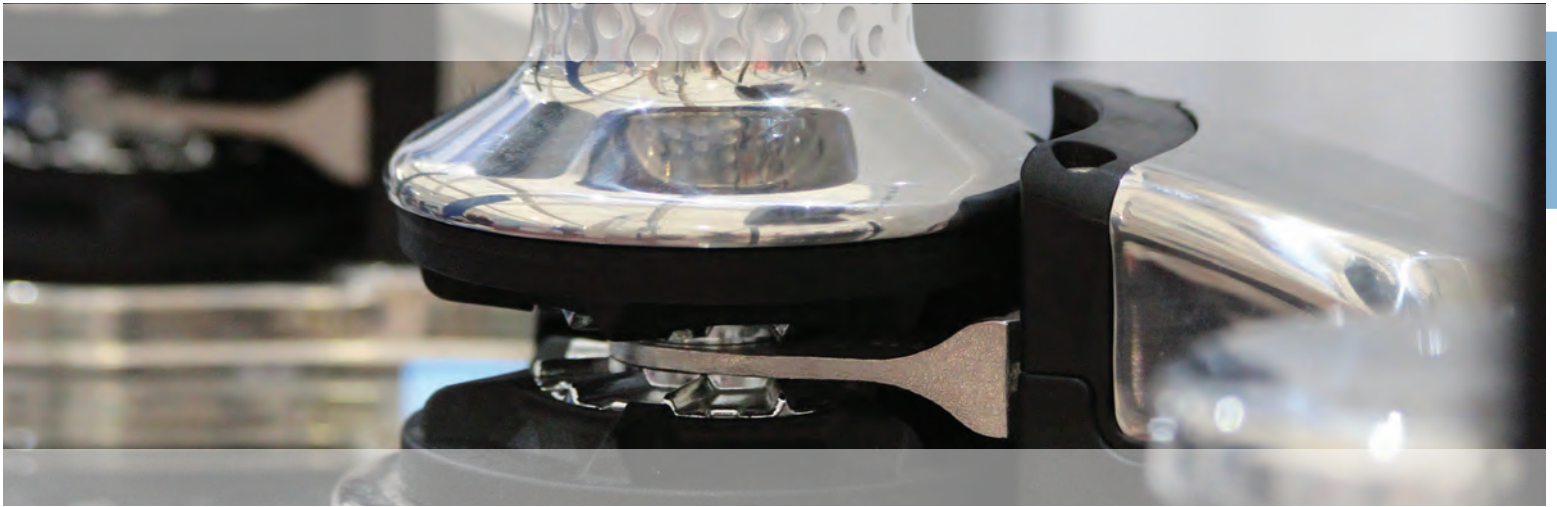

## Hybrid Polymer Gypsy

Lewmar has developed a patented Hybrid Gypsy, which uses a metal anchor warp core together with a polymer chain wheel. This combination offers a lightweight and quiet solution that ensures a smooth operation, while still offering the long-life durability of a traditional metal gypsy and pulling power. The Lewmar patented Hybrid Gypsy offers a 15% reduction in weight, is 5% stronger and offers an endurance life comparable to all metal gypsies. The Hybrid Gypsy's greatest attribute is the quietness when operating. The composite surface means there is no grating sound from metal-on-metal contact.

### Nickel-Plated Brass Core

A nickel-plated brass core is used for increased rope grip, utilising the proven design from our full windlass range.

### Hybrid Polymer Composite

Our engineering team are continually exploring, evaluating and testing new materials to ensure we offer cutting-edge products that are lighter, stronger and optimised for best performance.

### Chain Counter Magnet

Every Hybrid Gypsy is factory-fitted with a chain counter magnet, compatible with our full range of AutoAnchor products.

### Testing

Our endurance life test of the Hybrid Gypsy consisted of 6000 operations/300Km at varying load over a test period of three weeks to represent five years of use. One hybrid and one traditional gypsy have acted against each other at varying loads and line speeds, using a loop of 8mm chain. Using the test tank, test equipment was subjected to varying weather conditions.



GYPSY NUMBER	GYPSY	CHAIN DESCRIPTION	ROPE DESCRIPTION		ROPE TYPE
			MM	IN	
68100034	VX1 - 6/7MM 1/4"	6MM DIN766, 6MM ISO4565, 7MM DIN766, 7MM ISO4565, 1/4" ACCO ISO G43 (G4)1/4" ACCO BBB (3B)	12 - 16	1/2 - 5/8	3-STRAND AND 8-PLAIT
68100033	VX1 - 8MM 5/16"	8MM DIN766, 8MM ISO4565, 5/16" ACCO ISO G43 (G4)	12 - 16	1/2 - 5/8	3-STRAND AND 8-PLAIT
68120040	VX2/3 - 6/7MM 1/4"	6MM ISO4565, 7MM DIN766, 1/4" ACCO ISO G43 (G4)1/4" ACCO BBB (3B)	12 - 16	1/2 - 5/8	3-STRAND AND 8-PLAIT
68120041	VX2/3 - 8MM 5/16"	8MM DIN766, 8MM ISO4565, 5/16" ACCO ISO G43 (G4)	12 - 16	1/2 - 5/8	3-STRAND AND 8-PLAIT
68120042	VX2/3 - 10MM DIN	10MM DIN766, 5/16" CAMPBELL S3, 3/8" CAMPBELL S4, 9.5MM G40	12 - 16	1/2 - 5/8	3-STRAND AND 8-PLAIT
68120043	VX2/3 - 10MM ISO	10MM ISO4565, 5/16" CAMPBELL S3, LEWMAR 9.5MM G40	12 - 16	1/2 - 5/8	3-STRAND AND 8-PLAIT
68140009	HX1 - 6/7MM 1/4"	6MM DIN766, 6MM ISO4565, 7MM DIN766, 7MM ISO4565, 1/4" ACCO ISO G43 (G4)1/4" ACCO BBB (3B)	12 - 16	1/2 - 5/8	3-STRAND AND 8-PLAIT
68140010	HX1 - 8MM 5/16"	8MM DIN766, 8MM ISO4565, 5/16" ACCO ISO G43 (G4)	12 - 16	1/2 - 5/8	3-STRAND AND 8-PLAIT

# I. Windlasses

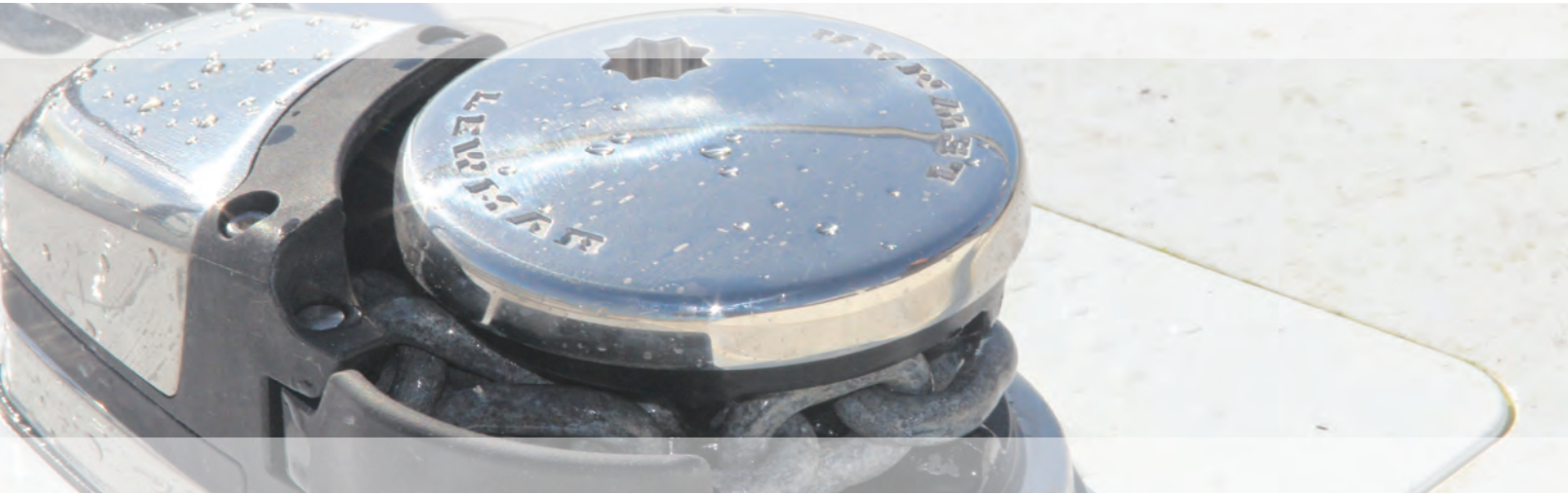

## VXI Vertical Windlass

The VXI is the first in the new generation of windlasses from Lewmar. Using cutting-edge moulding techniques, Lewmar is able to offer new technologies to refine windlass design and improve noise levels. Taking the tough and elegant lines of the V series, Lewmar have strived to remove excess weight - replacing heavy materials with modern composites - while retaining strength. A new motor-gearbox package has created our most efficient and powerful windlass, optimised for top anchoring performance. This makes our VX range lighter, stronger and more efficient than any competitor on the market.

- The VXI offers a maximum pull of 675kg, for boats up to 40ft
- 2 Hybrid Gypsy options: 6/7mm (1/4") & 8mm (5/16")
- 2 motor sizes: 300 & 500W
- Optimised motor-gearbox for enhanced performance
- Lightweight composite construction



### VXI Specifications

MODEL	MAX PULL		WORKING LOAD LIMIT		MAX LINE SPEED		NORMAL CURRENT DRAW AMP	CIRCUIT BREAKER AMP	APPROX WEIGHT GO		APPROX WEIGHT GD	
	KG	LB	KG	LB	M/MIN	FT/MIN			KG	LB	KG	LB
300W	400	882	100	220	25	82	66	50	12.5	28	13.5	30
500W	675	1488	169	373	25	82	126	70	12.5	28	13.5	30

### Dimensions Diagram

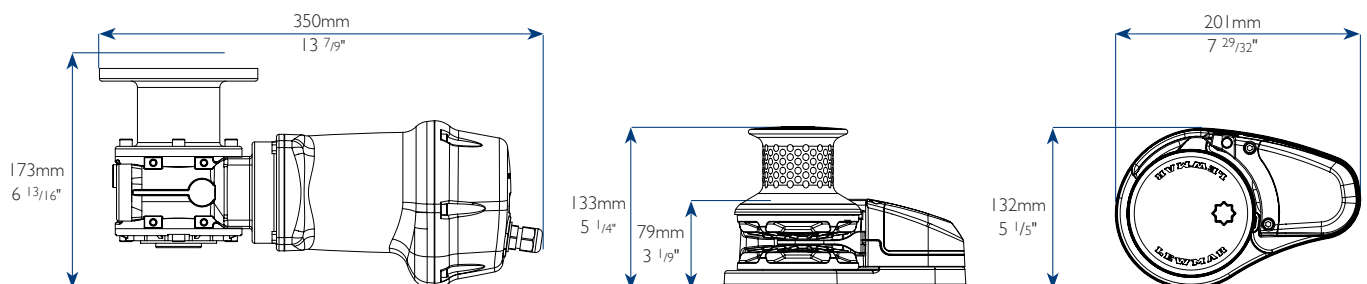

## VXI Features

### Deck unit

The Lewmar VX windlass range offers a new entry-level windlass product, giving the end user a stylish yet functional product at a competitive price point. Consisting of a cast aluminium core with composite outer and finished in a stainless steel pressing, giving the VXI its stylish design.

- Manual clutch release
- Drum option
- Stylish stainless steel and composite construction
- Same footprint as Lewmar VI model



### IP67 Rated Motor Gearbox

This will be the first ingress protection (IP) cover that Lewmar has offered on a windlass of this size. The cover is standard on all the VX windlass range.

Features:

- Silicone sealant free assembly
- Orientation flexibility that can be set by the end user
- Self-certified to Ingress Protection level 67 and to (EN 60529)
- This new IP cover is not backwards compatible with any RMI40 gearbox and not available on the VI, CPX0 700w or CPXI windlasses.
- Motor sizes: 300W or 500W

### VXI Standard Windlass Kits

PART NUMBER	DESCRIPTION
69100020	VX1 GO DECK UNIT 6/7MM 1/4" ST/ST 300W
69100021	VX1 GO DECK UNIT 6/7MM 1/4" ST/ST 500W
69100022	VX1 GO DECK UNIT 8MM 5/16" ST/ST 300W
69100023	VX1 GO DECK UNIT 8MM 5/16" ST/ST 500W
69100024	VX1 GD DECK UNIT 6/7MM 1/4" ST/ST 300W
69100025	VX1 GD DECK UNIT 6/7MM 1/4" ST/ST 500W
69100026	VX1 GD DECK UNIT 8MM 5/16" ST/ST 300W
69100027	VX1 GD DECK UNIT 8MM 5/16" ST/ST 500W

Standard windlass kit includes deck unit, motor gearbox, solenoid and gypsy

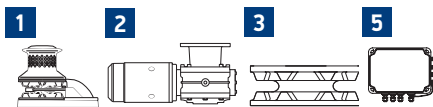

### VXI Extended Windlass Kits

PART NUMBER	DESCRIPTION
69100030	VX1 GO DECK UNIT 6/7MM 1/4" ST/ST 300W
69100031	VX1 GO DECK UNIT 6/7MM 1/4" ST/ST 500W
69100032	VX1 GO DECK UNIT 8MM 5/16" ST/ST 300W
69100033	VX1 GO DECK UNIT 8MM 5/16" ST/ST 500W
69100034	VX1 GD DECK UNIT 6/7MM 1/4" ST/ST 300W
69100035	VX1 GD DECK UNIT 6/7MM 1/4" ST/ST 500W
69100036	VX1 GD DECK UNIT 8MM 5/16" ST/ST 300W
69100037	VX1 GD DECK UNIT 8MM 5/16" ST/ST 500W

Extended windlass kit includes deck unit, motor gearbox, solenoid, gypsy, rocker switch and circuit breaker

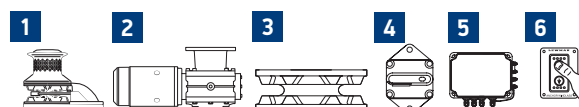

## 7 Optional Accessories

### Deck Spacer Kits

Min. recommended deck thickness is 40mm. 15mm VX1 & VX2/3 deck spacer kit used for decks with a thickness of 10mm - 25mm.

	PART NO.
VX1/2/3	66100143



Switch kit and accessories see page 52-60

# I. Windlasses



## VXIL Vertical Windlass

VXIL offers the same design features as the rest of the VX range, but with a compact in-line motor solution. The VXIL model is fitted with a refined motor and epicyclical gearbox combined with a small, compact and efficient motor. The VXIL is a great addition to our vertical windlass range, without compromising performance and freeing up space below deck.

The VXIL offers a maximum pull of 920kg, providing strong performance and robust design for boats up to 36ft.

- Manual clutch release
- Drum option
- Stylish stainless steel and composite construction
- 500W & 800W 12V motors available



### VXIL Specifications

MODEL	MAX PULL		WORKING LOAD LIMIT		MAX LINE SPEED		NORMAL CURRENT DRAW AMP	CIRCUIT BREAKER AMP	APPROX WEIGHT GO		APPROX WEIGHT GD	
	KG	LB	KG	LB	M/MIN	FT/MIN			KG	LBS	KG	LB
500W	650	1433	160	352	20	60	75	50	8	18	8.5	19
800W	920	2028	230	507	21	63	105	70	8	18	8.5	19

Windlass performance values are tested using +/-10% 12 voltage simulating the operation parameters of an installed battery system of a boat.



### Dimensions Diagram

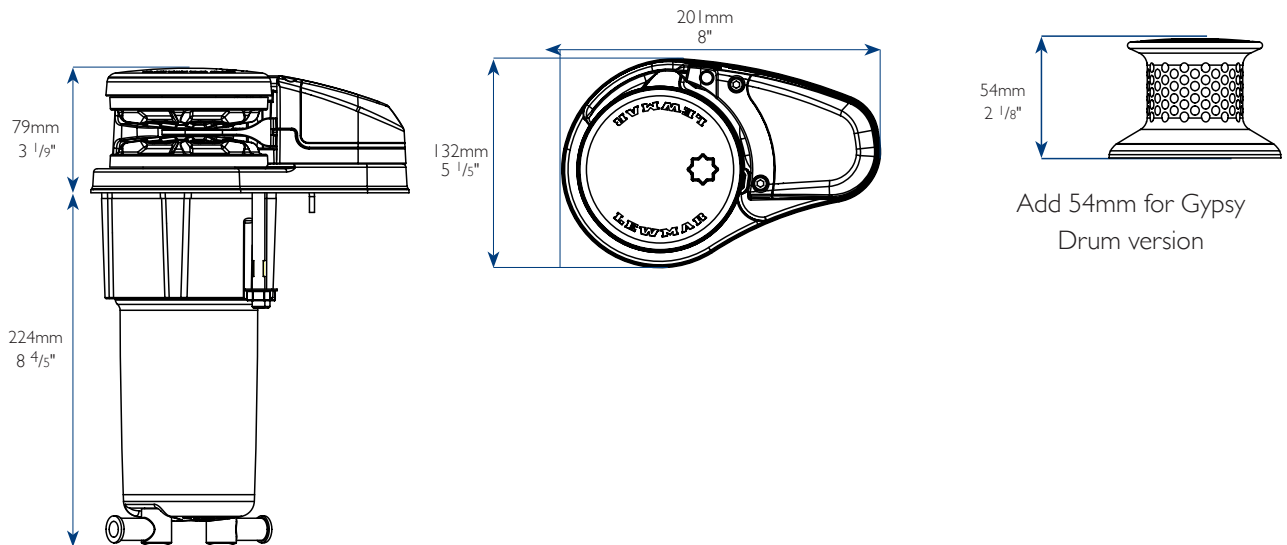

### VX1L Standard Windlass Kits

PART NUMBER	DESCRIPTION
69100050	VX1L G0 500 6/7MM 1/4" STD KIT
69100051	VX1L G0 800 6/7MM 1/4" STD KIT
69100052	VX1L G0 500 8MM 5/16" STD KIT
69100053	VX1L G0 800 8MM 5/16" STD KIT
69100054	VX1L GD 500 6/7MM 1/4" STD KIT
69100055	VX1L GD 800 6/7MM 1/4" STD KIT
69100056	VX1L GD 500 8MM 5/16" STD KIT
69100057	VX1L GD 800 8MM 5/16" STD KIT

VX1L Standard windlass kit includes deck unit and inline motor gearbox, solenoid and gypsy

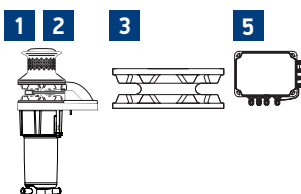

### VX1L Extended Windlass Kits

PART NUMBER	DESCRIPTION
69100060	VX1L G0 500 6/7MM 1/4" EXTD KIT
69100061	VX1L G0 800 6/7MM 1/4" EXTD KIT
69100062	VX1L G0 500 8MM 5/16" EXTD KIT
69100063	VX1L G0 800 8MM 5/16" EXTD KIT
69100064	VX1L GD 500 6/7MM 1/4" EXTD KIT
69100065	VX1L GD 800 6/7MM 1/4" EXTD KIT
69100066	VX1L GD 500 8MM 5/16" EXTD KIT
69100067	VX1L GD 800 8MM 5/16" EXTD KIT

Extended windlass kit includes deck unit and inline motor gearbox, solenoid, rocker switch, circuit breaker and gypsy

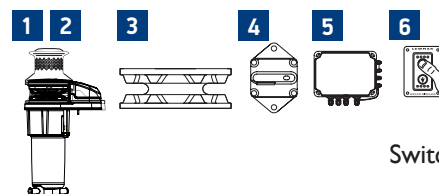

Switch kit and accessories see page 52-60

# I. Windlasses



## VX2/3 Vertical Windlass

Optimised for boats up to 48ft, the VX2/3 offers a maximum pull of 1175kg showing great performance and value. Built from the same principles of strength and durability as the V series, the VX2/3 units feature the same level of weight and performance optimisation as the VX1. The Hybrid Gypsy offers extended endurance under all conditions.

- 4 motor options: 700, 900, 1000 & 1500W
- IP67-rated motor housing as standard
- Maximum pull of 1175kg for boats up to 48ft
- 2 hybrid gypsy options: 6/7mm (1/4)' and 8mm (5/16")



### VX2/3 Specifications

MODEL	MOTOR POWER	VOLTAGE	MAX PULL		WORKING LOAD LIMIT		MAX LINE SPEED		NORMAL CURRENT DRAW	CIRCUIT BREAKER	APPROX WEIGHT		APPROX WEIGHT	
			KG	LB	KG	LB	M/MIN	FT/MIN			AMP	AMP	KG	LB
VX2	700W	12V	850	1874	213	470	29	95	120	90	13.9	31	14.9	33
VX2	900W	24V	850	1874	213	470	29	95	60	50	13.9	31	14.9	33
VX2+	1000W	12V	1025	2260	257	567	39	128	131	110	16.1	35	17.1	38
VX2+	1000W	24V	1025	2260	257	567	39	128	74	90	16.1	35	17.1	38
VX3	1500W	12V	1175	2590	294	648	40	131	132	110	16.1	35	17.1	38
VX3	1500W	24V	1175	2590	294	648	40	131	70	90	16.1	35	17.1	38

Windlass performance values are tested using +/-10% 12 voltage simulating the operation parameters of an installed battery system of a boat

### Dimensions Diagram

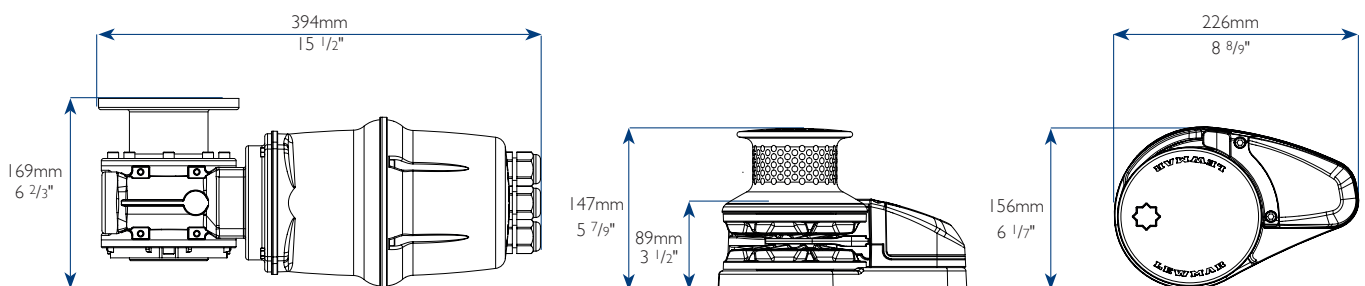

### VX2 Standard Windlass Kits

PART NUMBER	DESCRIPTION
69120020	VX2 GO 6/7MM 1/4" GYPSY 12V
69120021	VX2 GO 6/7MM 1/4" GYPSY 24V
69120022	VX2 GO 8MM 5/16" GYPSY 12V
69120023	VX2 GO 8MM 5/16" GYPSY 24V
69120024	VX2 GO 10DIN 5/16 / 3/8" GYPSY 12V
69120025	VX2 GO 10DIN 5/16 / 3/8" GYPSY 24V
69120026	VX2 GO 10ISO 5/16" GYPSY 12V
69120027	VX2 GO 10ISO 5/16" GYPSY 24V
69120050	VX2 GD 6/7MM 1/4" GYPSY 12V
69120051	VX2 GD 6/7MM 1/4" GYPSY 24V
69120052	VX2 GD 8MM 5/16" GYPSY 12V
69120053	VX2 GD 8MM 5/16" GYPSY 24V
69120054	VX2 GD 10DIN 5/16 / 3/8" GYPSY 12V
69120055	VX2 GD 10DIN 5/16 / 3/8" GYPSY 24V
69120056	VX2 GD 10ISO 5/16" GYPSY 12V
69120057	VX2 GD 10ISO 5/16" GYPSY 24V

### VX2+ Standard Windlass Kits

PART NUMBER	DESCRIPTION
69120030	VX2+ GO 6/7MM 1/4" GYPSY 12V
69120031	VX2+ GO 6/7MM 1/4" GYPSY 24V
69120032	VX2+ GO 8MM 5/16" GYPSY 12V
69120033	VX2+ GO 8MM 5/16" GYPSY 24V
69120034	VX2+ GO 10DIN 5/16 / 3/8" GYPSY 12V
69120035	VX2+ GO 10DIN 5/16 / 3/8" GYPSY 24V
69120036	VX2+ GO 10ISO 5/16" GYPSY 12V
69120037	VX2+ GO 10ISO 5/16" GYPSY 24V
69120060	VX2+ GD 6/7MM 1/4" GYPSY 12V
69120061	VX2+ GD 6/7MM 1/4" GYPSY 24V
69120062	VX2+ GD 8MM 5/16" GYPSY 12V
69120063	VX2+ GD 8MM 5/16" GYPSY 24V
69120064	VX2+ GD 10DIN 5/16 / 3/8" GYPSY 12V
69120065	VX2+ GD 10DIN 5/16 / 3/8" GYPSY 24V
69120066	VX2+ GD 10ISO 5/16" GYPSY 12V
69120067	VX2+ GD 10ISO 5/16" GYPSY 24V

### VX3 Standard Windlass Kits

PART NUMBER	DESCRIPTION
69120040	VX3 GO 6/7MM 1/4" GYPSY 12V
69120041	VX3 GO 6/7MM 1/4" GYPSY 24V
69120042	VX3 GO 8MM 5/16" GYPSY 12V
69120043	VX3 GO 8MM 5/16" GYPSY 24V
69120044	VX3 GO 10DIN 5/16 / 3/8" GYPSY 12V
69120045	VX3 GO 10DIN 5/16 / 3/8" GYPSY 24V
69120046	VX3 GO 10ISO 5/16" GYPSY 12V
69120047	VX3 GO 10ISO 5/16" GYPSY 24V
69120070	VX3 GD 6/7MM 1/4" GYPSY 12V
69120071	VX3 GD 6/7MM 1/4" GYPSY 24V
69120072	VX3 GD 8MM 5/16" GYPSY 12V
69120073	VX3 GD 8MM 5/16" GYPSY 24V
69120074	VX3 GD 10DIN 5/16 / 3/8" GYPSY 12V
69120075	VX3 GD 10DIN 5/16 / 3/8" GYPSY 24V
69120076	VX3 GD 10ISO 5/16" GYPSY 12V
69120077	VX3 GD 10ISO 5/16" GYPSY 24V

### VX2 Extended Windlass Kits

PART NUMBER	DESCRIPTION
69120080	VX2 GO 6/7MM 1/4" GYPSY 12V
69120081	VX2 GO 6/7MM 1/4" GYPSY 24V
69120082	VX2 GO 8MM 5/16" GYPSY 12V
69120083	VX2 GO 8MM 5/16" GYPSY 24V
69120084	VX2 GO 10DIN 5/16 / 3/8" GYPSY 12V
69120085	VX2 GO 10DIN 5/16 / 3/8" GYPSY 24V
69120086	VX2 GO 10ISO 5/16" GYPSY 12V
69120087	VX2 GO 10ISO 5/16" GYPSY 24V
69120110	VX2 GD 6/7MM 1/4" GYPSY 12V
69120111	VX2 GD 6/7MM 1/4" GYPSY 24V
69120112	VX2 GD 8MM 5/16" GYPSY 12V
69120113	VX2 GD 8MM 5/16" GYPSY 24V
69120114	VX2 GD 10DIN 5/16 / 3/8" GYPSY 12V
69120115	VX2 GD 10DIN 5/16 / 3/8" GYPSY 24V
69120116	VX2 GD 10ISO 5/16" GYPSY 12V
69120117	VX2 GD 10ISO 5/16" GYPSY 24V

### VX2+ Extended Windlass Kits

PART NUMBER	DESCRIPTION
69120090	VX2+ GO 6/7MM 1/4" GYPSY 12V
69120091	VX2+ GO 6/7MM 1/4" GYPSY 24V
69120092	VX2+ GO 8MM 5/16" GYPSY 12V
69120093	VX2+ GO 8MM 5/16" GYPSY 24V
69120094	VX2+ GO 10DIN 5/16 / 3/8" GYPSY 12V
69120095	VX2+ GO 10DIN 5/16 / 3/8" GYPSY 24V
69120096	VX2+ GO 10ISO 5/16" GYPSY 12V
69120097	VX2+ GO 10ISO 5/16" GYPSY 24V
69120120	VX2+ GD 6/7MM 1/4" GYPSY 12V
69120121	VX2+ GD 6/7MM 1/4" GYPSY 24V
69120122	VX2+ GD 8MM 5/16" GYPSY 12V
69120123	VX2+ GD 8MM 5/16" GYPSY 24V
69120124	VX2+ GD 10DIN 5/16 / 3/8" GYPSY 12V
69120125	VX2+ GD 10DIN 5/16 / 3/8" GYPSY 24V
69120126	VX2+ GD 10ISO 5/16" GYPSY 12V
69120127	VX2+ GD 10ISO 5/16" GYPSY 24V

### VX3 Extended Windlass Kits

PART NUMBER	DESCRIPTION
69120100	VX3 GO 6/7MM 1/4" GYPSY 12V
69120101	VX3 GO 6/7MM 1/4" GYPSY 24V
69120102	VX3 GO 8MM 5/16" GYPSY 12V
69120103	VX3 GO 8MM 5/16" GYPSY 24V
69120104	VX3 GO 10DIN 5/16 / 3/8" GYPSY 12V
69120105	VX3 GO 10DIN 5/16 / 3/8" GYPSY 24V
69120106	VX3 GO 10ISO 5/16" GYPSY 12V
69120107	VX3 GO 10ISO 5/16" GYPSY 24V
69120130	VX3 GD 6/7MM 1/4" GYPSY 12V
69120131	VX3 GD 6/7MM 1/4" GYPSY 24V
69120132	VX3 GD 8MM 5/16" GYPSY 12V
69120133	VX3 GD 8MM 5/16" GYPSY 24V
69120134	VX3 GD 10DIN 5/16 / 3/8" GYPSY 12V
69120135	VX3 GD 10DIN 5/16 / 3/8" GYPSY 24V
69120136	VX3 GD 10ISO 5/16" GYPSY 12V
69120137	VX3 GD 10ISO 5/16" GYPSY 24V

Standard windlass kit includes deck unit, motor gearbox, solenoid and gypsy

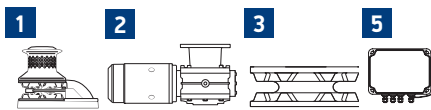

Extended windlass kit includes deck unit, motor gearbox, solenoid, gypsy, rocker switch and circuit breaker

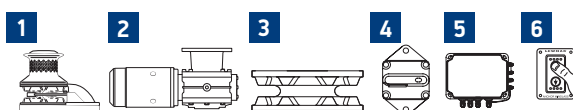

Switch kit and accessories see page 52-60

## 7 Optional Accessories

### Deck Spacer Kits

Min. recommended deck thickness for installation is 40mm. 15mm VX1 & VX2/3 deck spacer kit used for decks with a thickness of 10mm - 25mm.

	PART NO.
VX1/2/3	66100143



### Manual Recovery Kits

- Available for VX2/3
- Kit compatible with gypsy only & gypsy drum

	PART NO.
GYPSY ONLY	66120010
GYPSY DRUM	66000819



# I. Windlasses



## RX Horizontal Windlass

The RX offers a maximum pull of 775kg, offering great performance and value for the 30ft to 48ft market range. Designed as a discreet and compact unit, the RX is intended for use in confined chain lockers, where installation constraints prevent the use of a conventional horizontal unit.

- 4 hybrid gypsy options: 6/7mm (1/4"), 8mm (5/16"), 10mm DIN and 10mm ISO
- Stylish stainless steel and composite construction
- Motor gearbox outside separate to the chain locker to prevent water ingress
- IP67 Ingress protection as standard
- Motor gearbox can be rotated for 360° mounting



The specific angle of chain rode approach = Horizontal to -5°

### RX Specifications

MODEL	MOTOR POWER	VOLTAGE	MAX PULL		WORKING LOAD LIMIT		MAX LINE SPEED		NORMAL CURRENT DRAW AMP	CIRCUIT BREAKER AMP	APPROX WEIGHT GO		APPROX WEIGHT GD	
			KG	LB	KG	LB	M/MIN	FT/MIN			KG	LB	KG	LB
RX2	700W	12V	560	1235	140	310	29	95	120	90	12.9	28	13.9	30
RX2	900W	24V	560	1235	140	310	29	95	60	50	12.9	28	13.9	30
RX2+	1000W	12V	675	1490	170	375	39	128	131	110	15.1	32	16.1	35
RX2+	1000W	24V	675	1490	170	375	39	128	74	90	15.1	32	16.1	35
RX3	1500W	12V	775	1710	195	427	40	131	132	110	15.1	32	16.1	35
RX3	1500W	24V	775	1710	195	427	40	131	70	90	15.1	32	16.1	35

Windlass performance values are tested using +/-10% 12 voltage simulating the operation parameters of an installed battery system of a boat





### Dimensions Diagram

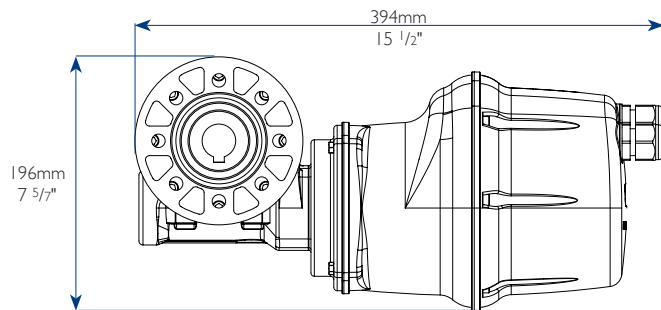
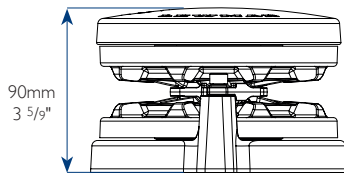

### RX Standard Windlass Kits

PART NUMBER	DESCRIPTION
69120140	RX2 G0 6/7MM 12V STD KIT
69120141	RX2 G0 6/7MM 24V STD KIT
69120142	RX2 G0 8MM 12V STD KIT
69120143	RX2 G0 8MM 24V STD KIT
69120144	RX2 G0 10MM DIN 12V STD KIT
69120145	RX2 G0 10MM DIN 24V STD KIT
69120146	RX2 G0 10MM ISO 12V STD KIT
69120147	RX2 G0 10MM ISO 24V STD KIT
69120148	RX2+ G0 6/7MM 12V STD KIT
69120149	RX2+ G0 6/7MM 24V STD KIT
69120150	RX2+ G0 8MM 12V STD KIT
69120151	RX2+ G0 8MM 24V STD KIT
69120152	RX2+ G0 10MM DIN 12V STD KIT
69120153	RX2+ G0 10MM DIN 24V STD KIT
69120154	RX2+ G0 10MM ISO 12V STD KIT
69120155	RX2+ G0 10MM ISO 24V STD KIT
69120156	RX3 G0 6/7MM 12V STD KIT
69120157	RX3 G0 6/7MM 24V STD KIT
69120158	RX3 G0 8MM 12V STD KIT
69120159	RX3 G0 8MM 24V STD KIT
69120160	RX3 G0 10MM DIN 12V STD KIT
69120161	RX3 G0 10MM DIN 24V STD KIT
69120162	RX3 G0 10MM ISO 12V STD KIT
69120163	RX3 G0 10MM ISO 24V STD KIT

Basic windlass kit includes deck unit, motor gearbox, solenoid and gypsy

### RX Extended Windlass Kits

PART NUMBER	DESCRIPTION
69120190	RX2 G0 6/7MM 12V EXTD KIT
69120191	RX2 G0 6/7MM 24V EXTD KIT
69120192	RX2 G0 8MM 12V EXTD KIT
69120193	RX2 G0 8MM 24V EXTD KIT
69120194	RX2 G0 10MM DIN 12V EXTD KIT
69120195	RX2 G0 10MM DIN 24V EXTD KIT
69120196	RX2 G0 10MM ISO 12V EXTD KIT
69120197	RX2 G0 10MM ISO 24V EXTD KIT
69120198	RX2+ G0 6/7MM 12V EXTD KIT
69120199	RX2+ G0 6/7MM 24V EXTD KIT
69120200	RX2+ G0 8MM 12V EXTD KIT
69120201	RX2+ G0 8MM 24V EXTD KIT
69120202	RX2+ G0 10MM DIN 12V EXTD KIT
69120203	RX2+ G0 10MM DIN 24V EXTD KIT
69120204	RX2+ G0 10MM ISO 12V EXTD KIT
69120205	RX2+ G0 10MM ISO 24V EXTD KIT
69120206	RX3 G0 6/7MM 12V EXTD KIT
69120207	RX3 G0 6/7MM 24V EXTD KIT
69120208	RX3 G0 8MM 12V EXTD KIT
69120209	RX3 G0 8MM 24V EXTD KIT
69120210	RX3 G0 10MM DIN 12V EXTD KIT
69120211	RX3 G0 10MM DIN 24V EXTD KIT
69120212	RX3 G0 10MM ISO 12V EXTD KIT
69120213	RX3 G0 10MM ISO 24V EXTD KIT

Extended windlass kit includes deck unit, motor gearbox, solenoid, gypsy, rocker switch and circuit breaker

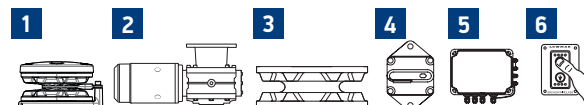

# I. Windlasses



## VX Capstan

VX Capstan offers the same design features as the VX IL windlass, but in a capstan. The VX Capstan model is fitted with an in-line motor and epicyclical gearbox which combines with a small, compact and efficient motor.

The VX Capstan is a great addition to our capstan range, without compromising performance and freeing up space below decks.

- IP67 rated motor housing as standard.
- Manual clutch release
- Drum only
- Stylish stainless steel and composite construction
- 800W 12v motor



### VX Capstan Specifications

MODEL	MOTOR POWER	VOLTAGE	MAX PULL		WORKING LOAD LIMIT		MAX LINE SPEED		NORMAL CURRENT DRAW AMP	CIRCUIT BREAKER AMP	APPROX WEIGHT	
			KG	LB	KG	LB	M/MIN	FT/MIN			KG	LB
VXC	800W	12	700	1543	175	385	21	63	58	70	7	15

Windlass performance values are tested using +/- 10% 12 voltage simulating the operation parameters of an installed battery system of a boat



Dimensions Diagram

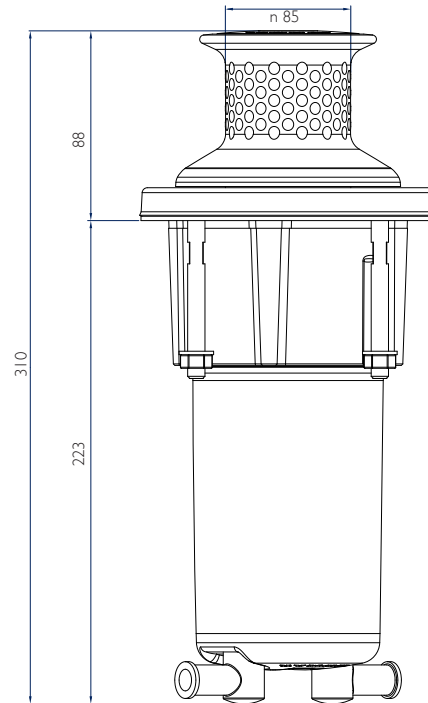
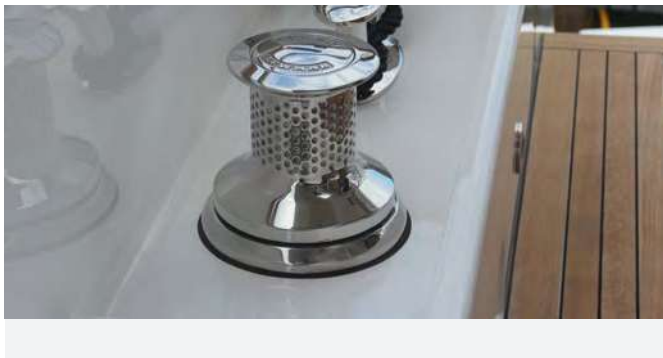
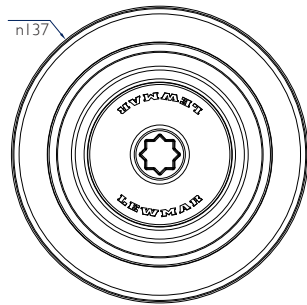

VX Standard Capstan Kits

PART NUMBER	DESCRIPTION
69100069	VX CAPSTAN 12V 800W STD KIT

Basic windlass kit includes deck unit with motor gearbox and solenoid

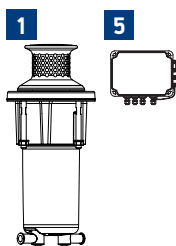

VX Extended Capstan Kits

PART NUMBER	DESCRIPTION
69100068	VX CAPSTAN 12V 800W EXTD KIT

Extended windlass kit includes deck unit with motor gearbox, solenoid, rocker switch and circuit breaker

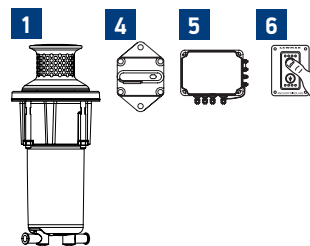

Switch kit and accessories see page 52-60

# I. Windlasses



## CPX0 Vertical Windlass

Lewmar's CPX vertical windlass range complements the current V Range. A lightweight alloy alternative, the CPX range uses quality materials throughout - hard-anodised aluminum for the base and cast stainless steel for the gypsy top cap and chain pipe cover. Precision-machined worm-wheel gearbox architecture ensures strength and performance.

- Lightweight design
- 500W or 700W motors
- Dual chain gypsy
- Highly reliable gearbox design



### CPX0 Specifications

MODEL	MAX PULL		WORKING LOAD LIMIT		MAX LINE SPEED		NORMAL CURRENT DRAW AMP	CIRCUIT BREAKER AMP	APP WEIGHT GYPSY ONLY	
	KG	LB	KG	LB	M/MIN	FT/MIN			KG	LB
CPX0 - 500W/12V	410	900	103	226	14	46	75	70	9.5	20.9
CPX0 - 700W/12V	600	1320	150	330	15.5	51	105	90	7.4	16.4

### Dimensions Diagram

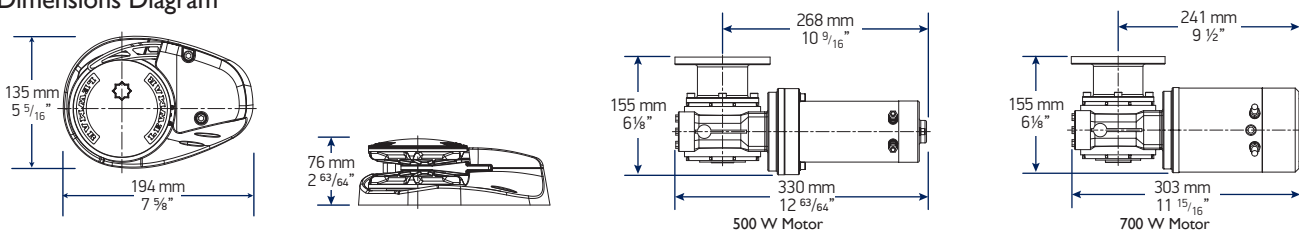

### CPX0 Standard Windlass Kits

PART NUMBER	DESCRIPTION
66910422	500W 6MM-7MM-1/4" WITH CHAIN COUNTER SENSOR
66910423	500W 6MM-7MM-1/4" NO SENSOR
66910424	500W 8MM-5/16" WITH CHAIN COUNTER SENSOR
66910425	500W 8MM-5/16" NO SENSOR
66910426	700W 6MM-7MM-1/4" WITH CHAIN COUNTER SENSOR
66910427	700W 6MM-7MM-1/4" NO SENSOR
66910428	700W 8MM-5/16" WITH CHAIN COUNTER SENSOR
66910429	700W 8MM-5/16" NO SENSOR

Standard windlass kit includes deck unit, motor gearbox, solenoid and gypsy

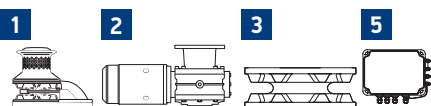

### CPX0 Extended Windlass Kits

PART NUMBER	DESCRIPTION
66910437	500W 6MM-7MM-1/4" WITH CHAIN COUNTER SENSOR AND SWITCH KIT
66910438	500W 8MM-5/16" WITH CHAIN COUNTER SENSOR AND SWITCH KIT
66910439	700W 6MM-7MM-1/4" WITH CHAIN COUNTER SENSOR AND SWITCH KIT
66910440	700W 8MM-5/16" WITH CHAIN COUNTER SENSOR AND SWITCH KIT

Extended windlass kit includes deck unit, motor gearbox, solenoid, gypsy, rocker switch and circuit breaker

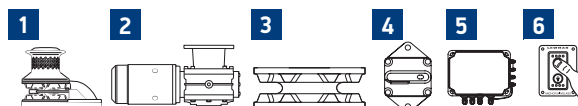



## CPX 1/2/3/4/5 Vertical Windlass

As a lightweight and robust windlass solution, the CPX performs to its maximum potential. Based on the design of the V series, the use of alloy components reduces weight by 15% without affecting performance. Care has been taken in the choice of materials throughout the deck unit and motor-gearbox to ensure longevity and durability.

- 15% lighter than comparable all-stainless windlass
- New architecture with reduced parts
- Straightforward to service
- Highly reliable, lightweight, high-performance windlass
- IP68 motor gearbox available on request



CPX Gypsy Only



CPX Gypsy/Drum

### CPX1/2/3/4 Specifications

MODEL	MOTOR POWER WATT	MAX PULL		WORKING LOAD LIMIT		MAX LINE SPEED		NORMAL CURRENT DRAW AMP	CIRCUIT BREAKER AMP	APP WEIGHT GYPSY ONLY		APP WEIGHT GYPSY/DRUM	
		KG	LB	KG	LB	M/MIN	FT/MIN			KG	LB	KG	LB
CPX1 12V	700	454	1000	113	250	19	65	80	90	17.5	38.5	-	-
CPX2 12V	700	650	1433	163	358	21	69	80	90	17.5	38.5	20.5	45.1
CPX2 24V	900	760	1675	180	396	24	79	45	50	17.5	38.5	20.5	45.1
CPX3 12V	1000	890	1962	215	473	28	92	85	110	20.0	44.0	23.0	50.6
CPX3 24V	1000	1020	2248	243	535	30	98	60	90	20.0	44.0	23.0	50.6
CPX4 12V	1600	1250	2750	313	688	25	82	125	150	26.5	58.3	33.5	73.7
CPX4 24V	2000	1500	3300	375	825	27	90	70	110	26.5	58.3	33.5	73.7
CPX5 12V	2000	1450	3190	363	798	27	90	120	150	28.5	62.7	35.5	150
CPX5 24V	2000	1600	3520	400	880	29	97	60	110	28.5	62.7	35.5	110

# I. Windlasses

## CPX Vertical Windlass

### Dimensions Diagram CPX1/2/3

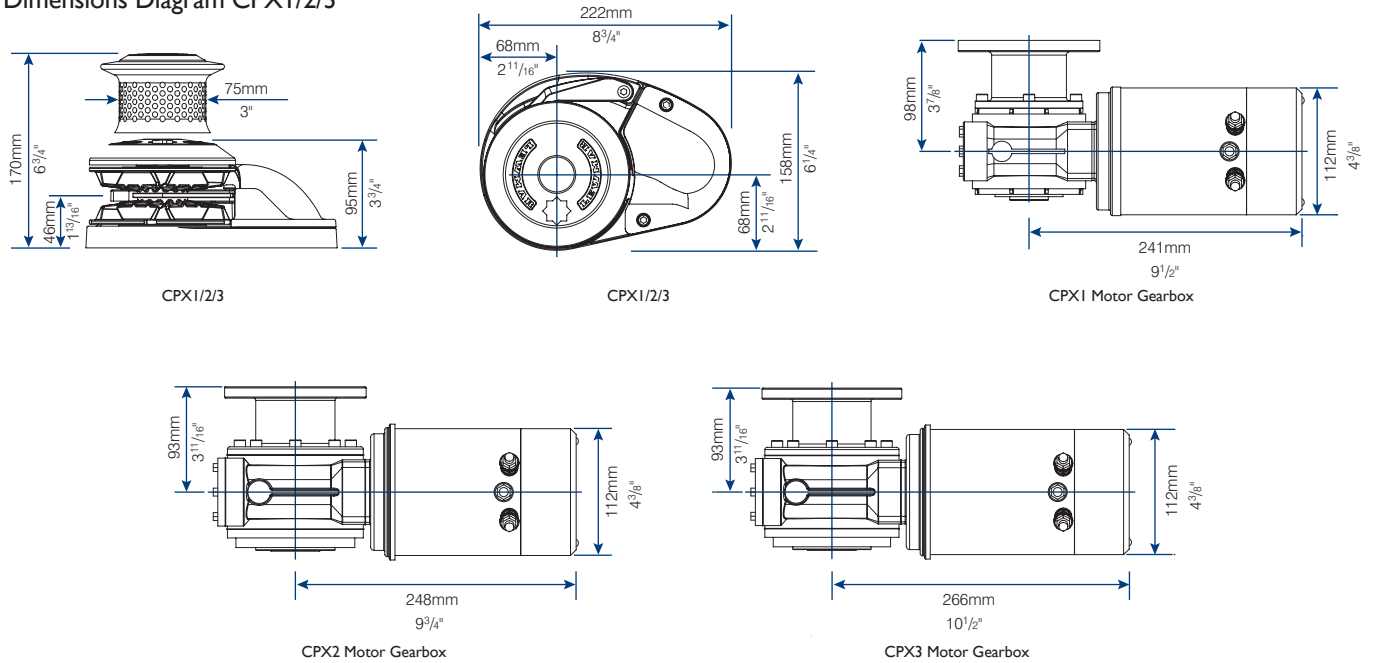

### Dimensions Diagram CPX4

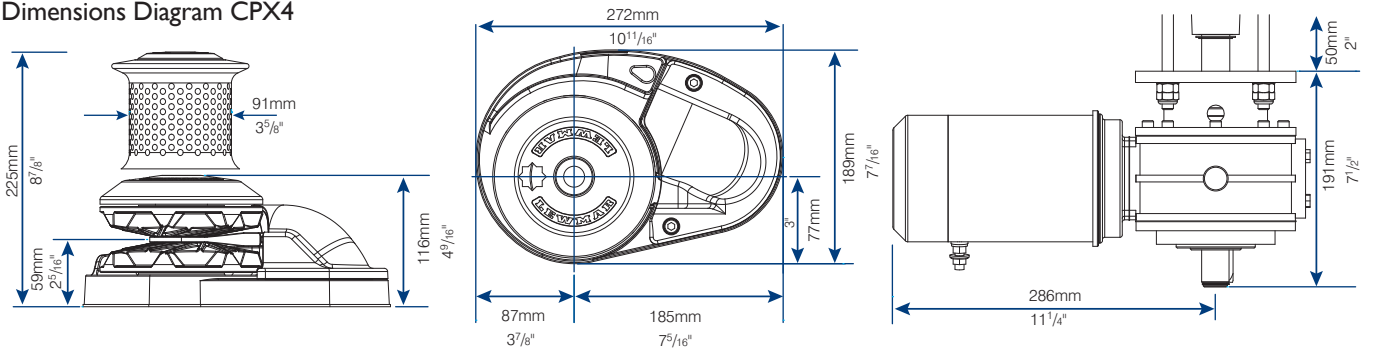

### CPX1/2/3 Complete Kit

PART NUMBER		MODEL	GYPSY NO - CHAIN DESCRIPTION	VOLTAGE
GYPSY ONLY	GYPSY DRUM			
6671011006	-	CPX1	006- 6MM ISO 4565, 1/4" G40°, 1/4" BBB	12V
6671011000	-	CPX1	000- 7MM ISO 4565, 1/4" G40°, 1/4" BBB	12V
6671011001	-	CPX1	001- 8MM DIN 766, 8MM ISO 4565, 5/16" G40	12V
6672011006	6672021006	CPX2	006- 6MM ISO 4565, 1/4" G40°, 1/4" BBB	12V
6672011000	6672021000	CPX2	000- 7MM ISO 4565, 1/4" G40°, 1/4" BBB	12V
6672011001	6672021001	CPX2	001- 8MM DIN 766, 8MM ISO 4565, 5/16" G40	12V
6672011002	6672021002	CPX2	002- 10MM DIN 766, CAMPBELL 3/8" S4	12V
6672011003	6672021003	CPX2	003- 10MM ISO, CAMPBELL 3/8" S3, LEWMAR 9.5MM G40	12V
6672012001	6672022001	CPX2	001- 8MM DIN 766, 8MM ISO 4565, 5/16" G40	24V
6672012002	6672022002	CPX2	002- 10MM DIN 766, CAMPBELL 3/8" S4	24V
6672211000	6672221000	CPX3	000- 7MM ISO 4565, 1/4" G40°, 1/4" BBB	12V
6672211001	6672221001	CPX3	001- 8MM DIN 766, 8MM ISO 4565, 5/16" G40	12V
6672211002	6672221002	CPX3	002- 10MM DIN 766, CAMPBELL 3/8" S4	12V
6672211003	6672221003	CPX3	003- 10MM ISO, CAMPBELL 3/8" S3, LEWMAR 9.5MM G40	12V
6672212001	6672222001	CPX3	001- 8MM DIN 766, 8MM ISO 4565, 5/16" G40	24V
6672212002	6672222002	CPX3	002- 10MM DIN 766, CAMPBELL 3/8" S4	24V
6672212003	6672222003	CPX3	003- 10MM ISO, CAMPBELL 3/8" S3, LEWMAR 9.5MM G40	24V

Windlass Kit includes deck unit, gypsy, motor gearbox, rocker switch, circuit breaker and contactor

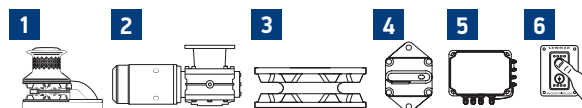

## CPX1/2/3/4 Specify your Windlass

### 1 Deck Unit

PART NO.	DESCRIPTION
69000493	CPX1 GYPSY ONLY
69000480	CPX2/3 GYPSY ONLY
69000483	CPX2/3 GYPSY DRUM
69000494	CPX4/5 GYPSY ONLY
69000495	CPX4/5 GYPSY DRUM

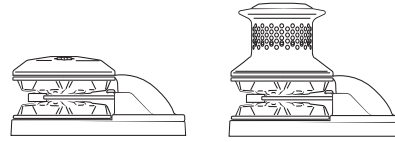

### 2 Motor Gearbox

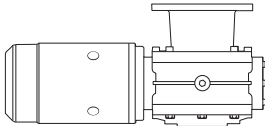

PART NO.	DESCRIPTION
68001068	CPX1 - 12V
68001069	CPX2 - 12V
68001070	CPX2 - 24V
68001071	CPX3 - 12V
68001072	CPX3 - 24V
68001077	CPX4 - 12V
68001078	CPX4 - 24V

#### IP68 motor gearbox available for CPX2 & 3

- Water resistant unit won't be damaged even if submerged in water
- Robust composite IP68 Motor Case
- Compression cable clamps included
- No maintenance required
- Provide the best motor protection against the elements

PART NO.	DESCRIPTION
68001073	CPX2 12V IP68 MOTOR GEARBOX ASSY - NO CABLES
68001074	CPX2 24V IP68 MOTOR GEARBOX ASSY - NO CABLES
68001075	CPX3 12V IP68 MOTOR GEARBOX ASSY - NO CABLES
68001076	CPX3 24V IP68 MOTOR GEARBOX ASSY - NO CABLES

### 3 Gypsy

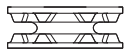

PART NO.	GYPSY NUMBER	TO FIT WINDLASS	CHAIN DESCRIPTION	ROPE SIZE		ROPE DESCRIPTION
				MM	IN	
68001047	006	CPX1/2/3	6MM ISO 4565, 1/4" G40*, 1/4" BBB	12-14	1/2	3-STRAND AND 8-PLAIT
68001048	000	CPX1/2/3	7MM ISO 4565, 1/4" G40*, 1/4" BBB	12-14	1/2	3-STRAND AND 8-PLAIT
68001049	001	CPX1/2/3	8MM DIN 766, 8MM ISO 4565, 5/16" G40	12-16	1/2-5/8	3-STRAND AND 8-PLAIT (5/8 ONLY)
68001050	002	CPX1/2/3	10MM DIN 766, CAMPBELL 3/8" S4, 5/16" G40	12-16	1/2-5/8	3-STRAND AND 8-PLAIT (5/8 ONLY)
68001051	003	CPX1/2/3	10MM ISO, CAMPBELL 3/8" S3, LEWMAR 9.5MM G40	16	5/8	3-STRAND AND 8-PLAIT
68001063	201	CPX4	8MM DIN 766, 8MM ISO 4565, 5/16" G40, 5/16" CAMPBELL S4	12-14	1/2	3 STRAND
68001064	202	CPX4	10MM DIN 766, 5/16" CAMPBELL S3, 3/8" CAMPBELL S4, 9.5MM G30	16	5/8	3 STRAND
68001065	203	CPX4	10MM ISO 4565, 3/8" CAMPBELL S3, LEWMAR 9.5MM G40	16	5/8	3 STRAND
68001066	204	CPX4	12MM ISO 4565, 13MM DIN 766	18-20	3/4	3 STRAND

\*G40 = Grade 40 Short Link Chain

### Switch kit and accessories

#### 4 Circuit breaker

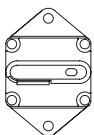

#### 5 Contactor/ control box

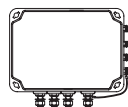

#### 6 Switch and accessories

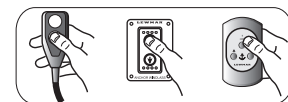

#### 7 Optional Accessories



Bulkhead Fittings  
3 gland: 68000866



Manual recovery kit for CPX1/2/3  
Gypsy only: 66840056  
Gypsy/Drum: 66840054



Manual Handle  
29140017

# I. Windlasses



## V700 Vertical Windlass

With 316 stainless steel housing and a sleek flush-mount design, the V700 is one of the most attractive and durable small windlasses on the market. It works at the push of a button and has two built-in features that make it unique – impact protection and a Fall Safe gypsy lock.

- 316 stainless steel deck unit
- IP67 rated (water resistant to 1 metre)
- Fall Safe gypsy lock - prevents accidental deployment when under way
- Impact-resistant motor cover
- 5-year warranty
- For boats up to 10.5m (35 ft)



### V700 Specifications

PART NUMBER	DESCRIPTION	GYPSY NO.	MOTOR SUPPLY VOLTAGE	MOTOR POWER WATT	MAX PULL		WORKING LOAD LIMIT		MAX LINE SPEED		TYPICAL LINE SPEED		NORMAL CURRENT DRAW AMP	CIRCUIT BREAKER AMP	WEIGHT GYPSY ONLY	
					KG	LB	KG	LB	M/MIN.	FT/MIN.	M/MIN	FT/MIN			KG	LB
6670011108-312	V700 12V 6/7MM/1/4" KIT*	603	12	320	320	700	79	175	25	82	15	50	45	35	6.5	14
6670011108	V700 12V 6/7MM/1/4" WINDLASS ONLY NO SWITCH KIT	603	12	320	320	700	79	175	25	82	15	50	45	35 (NOT SUPPLIED)	6.5	14

\* Kit includes contactor and circuit breaker

### Dimensions Diagram

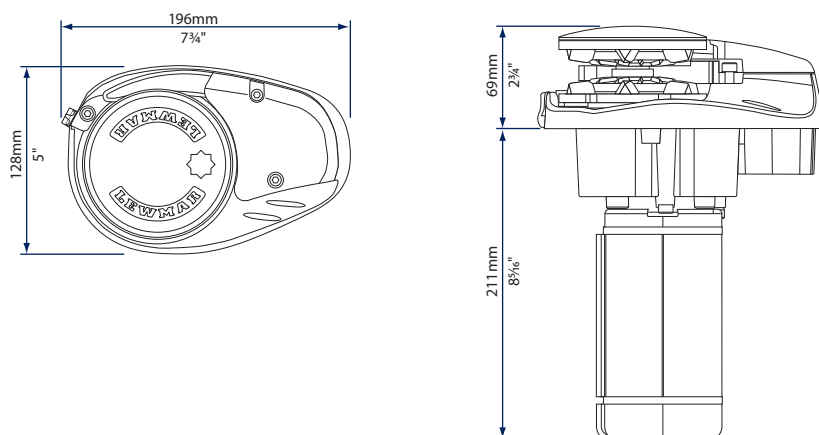

### Dual Chain Gypsy

The V700 comes with a gypsy able to accept both 6mm and 7mm (1/4) inch chains.

- Fits calibrated chains: 6mm DIN766, 1/4" G4 or BBB, 7mm DIN766
- Minimal parts for enhanced reliability







## VI/V2/V3 Vertical Windlasses

The V Series represents the pinnacle of Lewmar's windlass development. Robust stainless steel deck units combined with powerful motors, the V Series is capable of withstanding the toughest conditions. Designed as the ideal anchoring companion for all serious boaters, the V Series windlasses are strong, beautiful and dependable.

- Rope-chain gypsy
- Manual chain release (Free Fall)
- Cone clutch for smooth, easy control
- Optional manual override motor gearbox
- W.A.R.P Drum
- Fall Safe anchor lock
- Worm gearbox
- FastFit™ option for quicker installation and less hassle
- Emergency recovery kit available
- Water resistant IP68 kits available
- For boats up to 14m (48ft)



### VI/V2/V3 Specifications

MODEL	MOTOR POWER	MAX PULL		WORKING LOAD		MAX LINE SPEED		NORMAL CURRENT DRAW AMP	CIRCUIT BREAKER AMP	APP WEIGHT GYPSY ONLY		APP WEIGHT GYPSY/DRUM	
	WATT	KG	LB	KG	LB	M/MIN	FT/MIN			KG	LB	KG	LB
V1	700	750	1653	188	414	19	65	80	90	19	42	-	-
V2 12V	700	850	1874	213	470	21	69	80	90	19	42	22	48.5
V2 24V	900	850	1874	213	470	24	79	45	50	19	42	22	48.5
V3 12V	1000	1025	2260	257	567	28	92	85	110	21.5	47	24.5	54
V3 24V	1000	1025	2260	257	567	30	98	60	90	21.5	47	24.5	54

### FastFit™ Feature

FastFit™ motor gearbox attachment enables the windlass to be fitted by one person. While the gearbox alignment to the deck unit is critical to a standard installation, the FastFit™ clamping system perfectly aligns the deck unit and motor-gearbox for a perfect fit first time.

- FastFit™ enable the motor / gearbox to be rotated and fixed in increments of 45°
- To install your windlass, simply fix the deck unit to the deck and then slide the gearbox up the shaft, swing the FastFit™ clamp shut and tighten up the bronze nut.



# I. Windlasses

## Dimensions Diagram

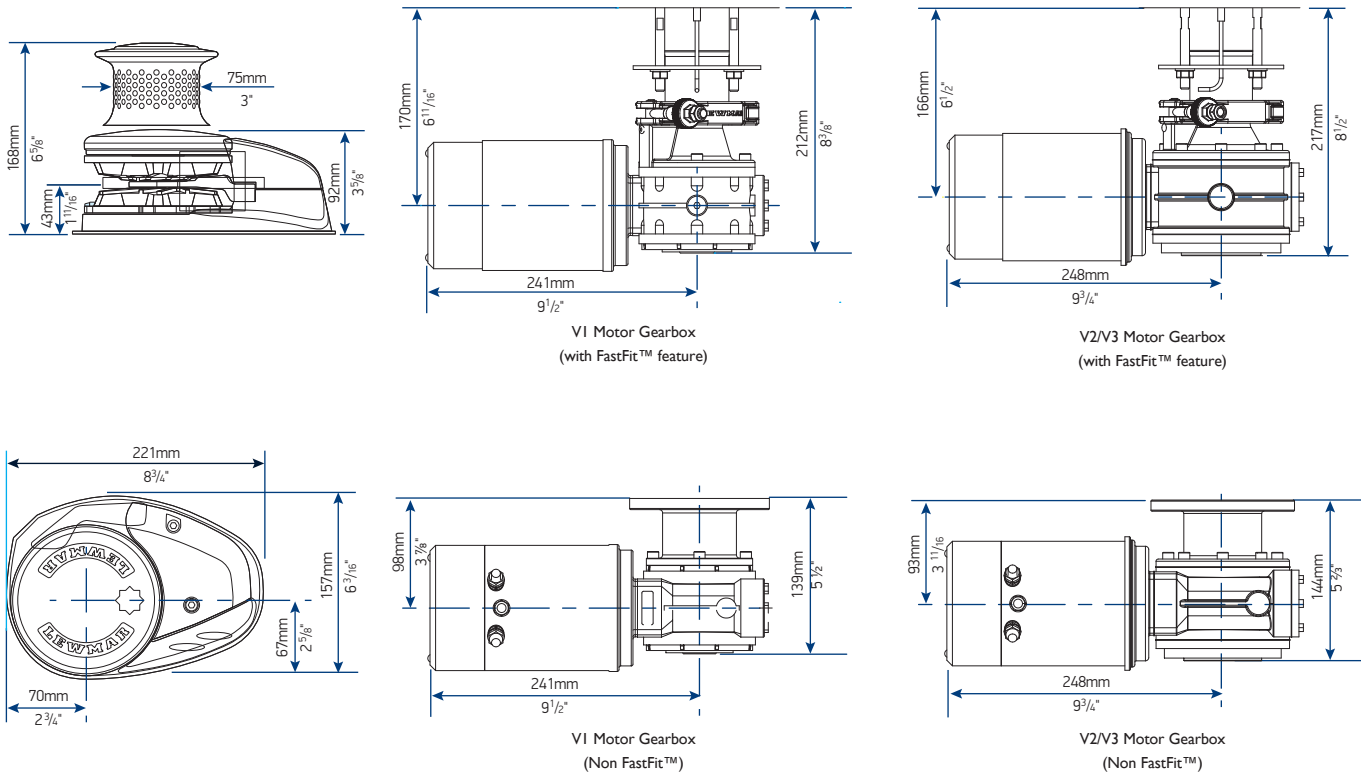

## VI/V2/V3 Complete Kit - Include Fastfit™ feature

GYPSY ONLY	GYPSY DRUM	MODEL	GYPSY NO- CHAIN DESCRIPTION	VOLTAGE
6671011107-138 (USA ONLY)	-	V1	000- 7MM ISO 4565, 1/4" G40°, 1/4" BBB	12
6671011108-138 (USA ONLY)	-	V1	002- 10MM DIN 766, CAMPBELL 3/8" S4, 5/16" G40	12
6671011196-138	-	V1	006- 6MM ISO 4565, 1/4" G40°, 1/4" BBB	12
6671011197-138	-	V1	000- 7MM ISO 4565, 1/4" G40°, 1/4" BBB	12
6671011198-138	-	V1	001- 8MM DIN 766, 8MM ISO 4565, 5/16" G40	12
6672011196-138	6672021196-138	V2	006- 6MM ISO 4565, 1/4" G40°, 1/4" BBB	12
6672011197-138	6672021197-138	V2	000- 7MM ISO 4565, 1/4" G40°, 1/4" BBB	12
6672011198-138	6672021198-138	V2	001- 8MM DIN 766, 8MM ISO 4565, 5/16" G40	12
6672011108-138	6672021108-138	V2	002- 10MM DIN 766, CAMPBELL 3/8" S4, 5/16" G40	12
6672011110-138	6672021110-138	V2	003- 10MM ISO, CAMPBELL 3/8" S3, LEWMAR 3/8" G40	12
6672012198-140	6672022198-140	V2	001- 8MM DIN 766, 8MM ISO 4565, 5/16" G40	24
6672012108-140	6672022108-140	V2	002- 10MM DIN 766, CAMPBELL 3/8" S4, 5/16" G40	24
6672211197-139	6672221197-139	V3	000- 7MM ISO 4565, 1/4" G40°, 1/4" BBB	12
6672211198-139	6672221198-139	V3	001- 8MM DIN 766, 8MM ISO 4565, 5/16" G40	12
6672211108-139	6672221108-139	V3	002- 10MM DIN 766, CAMPBELL 3/8" S4, 5/16" G40	12
6672211110-139	6672221110-139	V3	003- 10MM ISO, CAMPBELL 3/8" S3, LEWMAR 9.5MM G40	12
6672212198-142	66722212198-142	V3	001- 8MM DIN 766, 8MM ISO 4565, 5/16" G40	24
6672212108-142	66722212108-142	V3	002- 10MM DIN 766, CAMPBELL 3/8" S4, 5/16" G40	24
6672212110-142	66722212110-142	V3	003- 10MM ISO, CAMPBELL 3/8" S3, LEWMAR 3/8" G40	24

Above kits all feature Fastfit™ motor gearboxes

Windlass Kit includes deck unit, gypsy, motor gearbox, rocker switch, circuit breaker and contactor

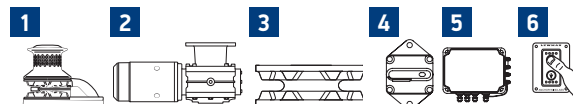

## V1/V2/V3 Vertical Windlasses

### Specify your V1/V2/V3

#### 1 Deck Unit

PART NO. (NON FASTFIT)	PART NO. (FASTFIT)	DESCRIPTION
69000481	68000951	V1 GYPSY ONLY
69000484	68000828	V2/3 GYPSY ONLY
69000485	68000829	V2/3 GYPSY DRUM

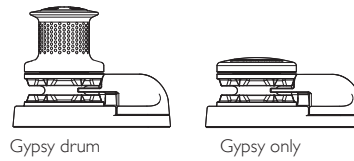

#### 2 Motor Gearbox

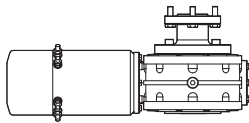

#### IP68 motor gearbox available (non FastFit™)

- Water resistant unit will not be damaged even if submerged under water
- Robust composite case
- Compression cable clamps included
- No maintenance required
- Provide best motor protection against the elements

PART NO. (NON FASTFIT)	PART NO. (FASTFIT)	DESCRIPTION
68001055	66810065	V1-12V
68000527	68000813	V2 - 12V
68000538	68000814	V2 - 24V
66810007	68000815	V3 - 12V
66810008	68000816	V3 - 24V

PART NO.	DESCRIPTION
68001052	V2 12V IP68 MOTOR GEARBOX ASSY - NO CABLES
68001053	V2 24V IP68 MOTOR GEARBOX ASSY - NO CABLES
66810132	V3 12V IP68 MOTOR GEARBOX ASSY - NO CABLES
68001054	V3 24V IP68 MOTOR GEARBOX ASSY - NO CABLES

#### 3 Gypsy



PART NO.	GYPSY NUMBER	CHAIN DESCRIPTION	ROPE SIZE		ROPE DESCRIPTION
			MM	IN	
68000840	006	6MM ISO 4565, 1/4" G40*, 1/4" BBB	12-14	1/2	3-STRAND AND 8-PLAIT
68000360	000	7MM ISO 4565, 1/4" G40*, 1/4" BBB	12-14	1/2	3-STRAND AND 8-PLAIT
68000361	001	8MM DIN 766, 8MM ISO 4565, 5/16" G40	12-16	1/2 - 5/8	3-STRAND AND 8-PLAIT (5/8 ONLY)
68000362	002	10MM DIN 766, CAMPBELL 3/8" S4, 5/16" G40	12-16	1/2 - 5/8	3-STRAND AND 8-PLAIT (5/8 ONLY)
68000363	003	10MM ISO, CAMPBELL 3/8" S3, LEWMAR 3/8" G40	16	5/8	3-STRAND AND 8-PLAIT

\*G40 = Grade 40 Short Link Chain

#### Switch kit and accessories

##### 4 Circuit breaker

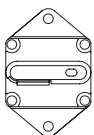

##### 5 Contactor/ control box

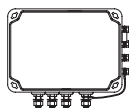

##### 6 Switch and accessories

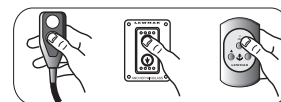

Switch kit and accessories see page 52-60

#### 7 Optional Accessories



Control arm kit:  
66810030



Manual recovery kit  
Gypsy only: 66840054  
Gypsy/Drum: 66840056



Bulkhead Fitting  
3 gland: 68000866



Manual Handle  
29140017

# I. Windlasses

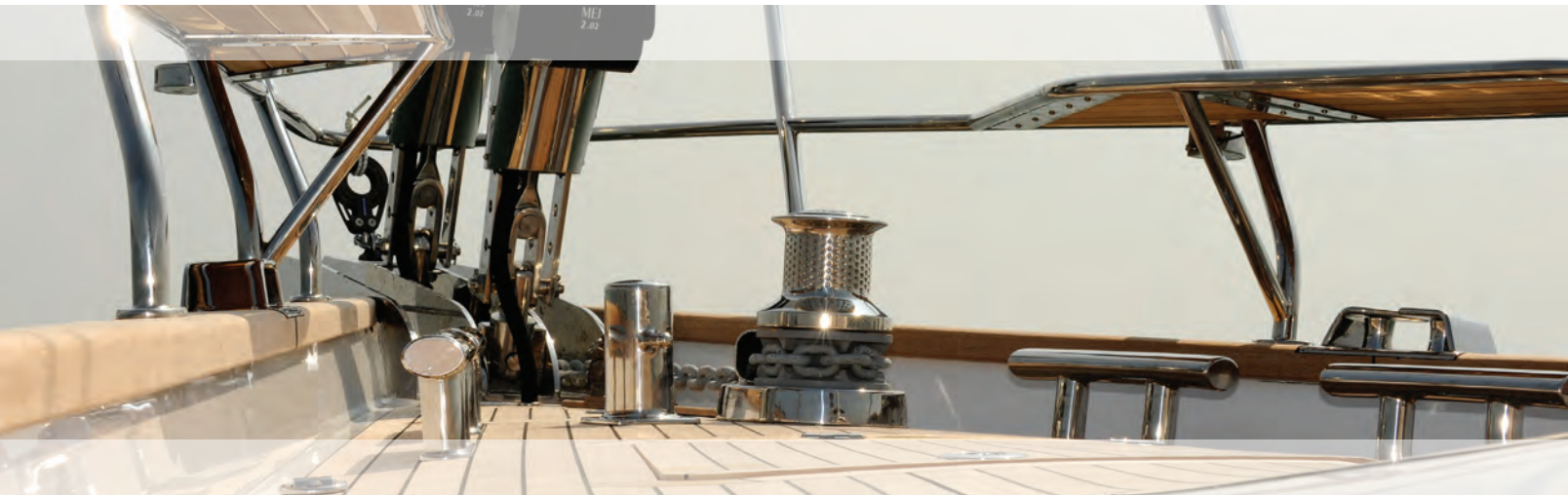

## V4/V5 Vertical Windlasses

The V4/V5 vertical windlass features a lightweight and strong deck unit manufactured from precision cast 316 grade stainless steel with a robust drive train. Available as gypsy or gypsy drum in either 12 volt or 24 volt models.

- Rope-chain gypsy
- Cone clutch for smooth, easy control
- Manual Free Fall
- W.A.R.P Drum
- Robust and reliable drive train
- Manual override (optional)



V4/V5 Gypsy/  
Drum



V4/V5  
Gypsy Only

### V4/V5 Electric Specifications

MODEL	MOTOR POWER WATT	MAX PULL		WORKING LOAD LIMIT		MAX LINE SPEED		NORMAL CURRENT DRAW AMP	CIRCUIT BREAKER AMP	APP WEIGHT GYPSY ONLY		APP WEIGHT GYPSY/DRUM	
		KG	LB	KG	LB	M/MIN	FT/MIN			KG	LB	KG	LB
V4 12V	1600	1250	2750	313	688	25	82	125	150	29	64	36	79
V4 24V	2000	1500	3306	375	798	27	90	70	110	29	64	36	79
V5 12V	2000	1450	3190	363	825	27	90	120	150	31	68	38	84
V5 24V	2000	1600	3520	400	880	29	97	60	110	31	68	38	84



### V4/V5 Hydraulic Specifications

PRODUCT	PRESSURE MAX	FLOW RATE	MAX. PULL		MAX. LINE SPEED	
			KG	LB	M/MIN	FT/MIN
V4/5 HYD	175 BAR 2537 PSI (CONT)	10-40 L/MIN 2.6-10.6 US GAL/MIN	1100 AT 140 BAR	2400 AT 203 PSI	21 AT 40 L/MIN	69 AT 10.6 US GAL/MIN

Hydraulic motor gearboxes are suitable for use with both V4/V5 and C4/CS.

### V4 Dimensions Diagram

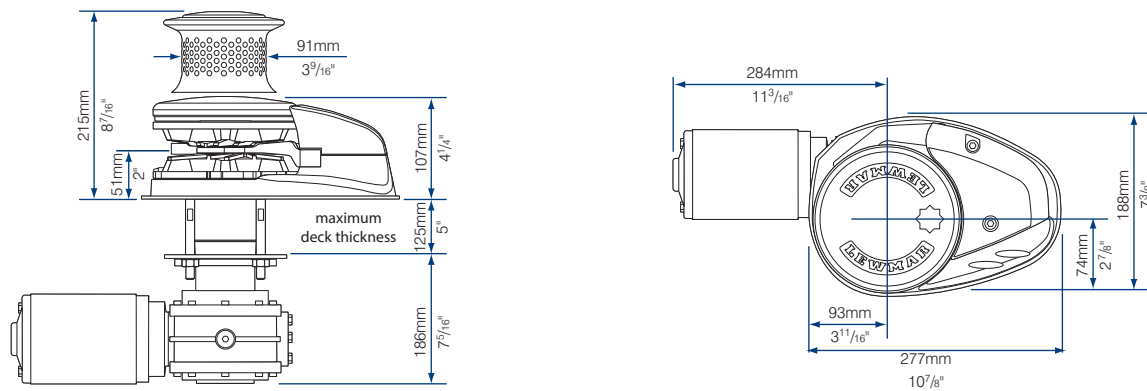

### V5 Dimensions Diagram

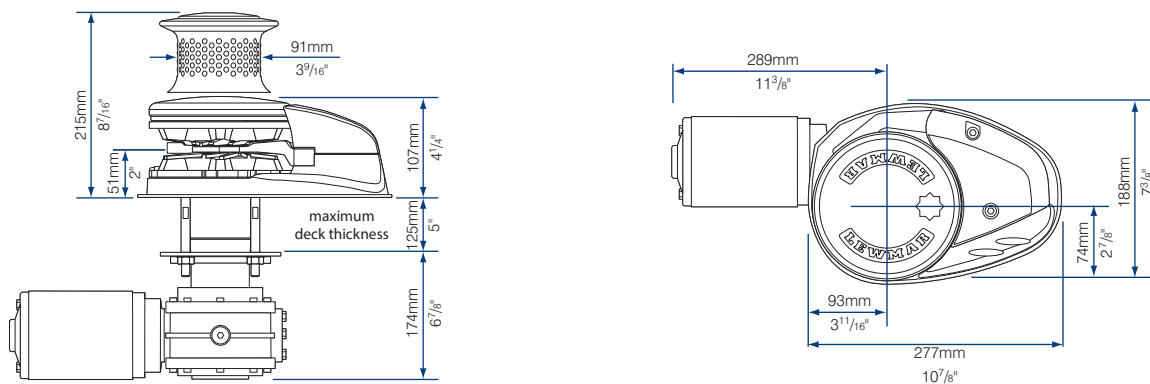

# I. Windlasses

Specify your V4/V5

## 1 Deck Unit

PART NO.	DESCRIPTION
66810024	V4/5 GYPSY ONLY
66810025	V4/5 GYPSY DRUM

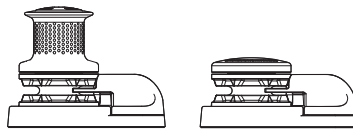

## 2 Motor Gearbox

PART NO.	DESCRIPTION
68000534	V4 - 12V
68000535	V4 - 24V
66810011	V5 - 12V
66810012	V5 - 24V
68000294	V4/5 HYDRAULIC

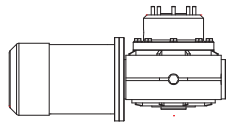

## 3 Gypsy

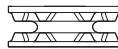

PART NO.	GYPSY NUMBER	CHAIN DESCRIPTION	ROPE DESCRIPTION		
			MM	IN	
68000356	201	8MM DIN 766, 8MM ISO 4565, 5/16" G40, 5/16" CAMPBELL S4	12-14	1/2	3 STRAND
68000357	202	10MM DIN 766, 5/16" CAMPBELL S3, 3/8" CAMPBELL S4, 9.5MM G30	16	5/8	3 STRAND
68000358	203	10MM ISO 4565, 3/8" CAMPBELL S3, LEWMAR 9.5MM (3/8") G40	16	5/8	3 STRAND
68000359	204	12MM ISO 4565, 13MM DIN 766, 7/16" G40	18-20	3/4	3 STRAND

Switch kit and accessories

## 4 Circuit breaker

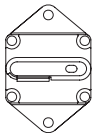

## 5 Contactor/ control box

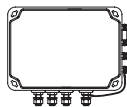

## 6 Switch and accessories

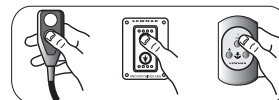

Switch kit and accessories  
see page 52-60

## 7 Optional Accessories



Control arm kit:  
66810031



Manual recovery kit  
Gypsy only: 66840003  
Gypsy/Drum: 66840005



Bulkhead Fittings  
3 gland: 68000866  
4 gland: 68000867





## V6 Vertical Windlass

Designed for vessels of 60ft and above, the V6 Vertical Windlass has Lloyd's Type Approval, guaranteeing quality and performance. The windlass is available as gypsy only and gypsy drum in left and right-hand configuration. A host of features including 24V, hydraulic, wide range of gypsies, stainless steel W.A.R.P (Wear and Abrasion Resistant Pattern) drum and a cone clutch for smooth, easy control.

- All stainless steel deck unit
- Powered and manual chain release
- For boats up to 24m (80ft)
- Cone Clutch for smooth, easy control
- Left and right-hand versions
- Available in 24 V and Hydraulic power options
- Lloyd's Type Approval
- W.A.R.P. Drum  
(Wear and Abrasion Resistant Pattern)
- Remote chain-pipe version

For use with any size chain, but recommended when using 14mm chain



### V6 Electric Specifications

MODEL	MOTOR POWER WATT	MAX PULL		WORKING LOAD LIMIT		MAX LINE SPEED		NORMAL CURRENT DRAW AMP	CIRCUIT BREAKER AMP	WEIGHT	
		KG	LB	KG	LB	M/MIN	FT/MIN			KG	LB
V6 24V	2000	1800	3960	450	990	18	59	90	150	63	139

### V6 Hydraulic Specifications

PRODUCT	NORMAL PRESSURE	FLOW RATE	MAX. PULL		MAX. LINE SPEED		WEIGHT	
			KG	LB	M/MIN	FT/MIN	KG	LB
V6 HYDRAULIC	60 BAR 882 PSI (CONT)	20-60 L/MIN 5.2-15.8 US GAL/MIN	1450 AT 190 BAR	3190 AT 2793 PSI	34 AT 60 L/MIN	110 AT 15.9 US GAL/MIN	52	114

# I. Windlasses

## V6 Vertical Windlasses

### Dimensions Diagram

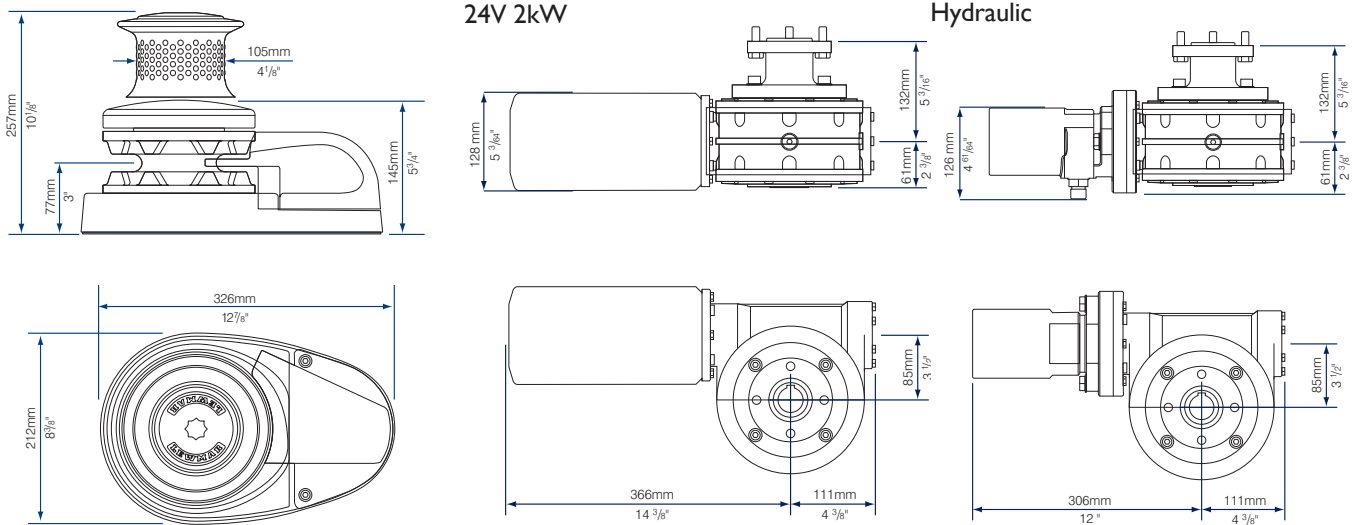

### V6 Part Numbers

#### 1 Deck Unit



PART NO.	DESCRIPTION
69000400	V6 DECK UNIT LH GYPSY DRUM
69000401	V6 DECK UNIT RH GYPSY DRUM
69000402	V6 DECK UNIT LH GYPSY ONLY
69000403	V6 DECK UNIT RH GYPSY ONLY
69000404	V6 DECK UNIT UNI GYPSY /DRUM
69000405	V6 DECK UNIT UNI GYPSY ONLY

#### 2 Motor Gearbox

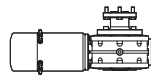

PART NO.	DESCRIPTION
69000407	V6 - 24V MOTOR/GEARBOX ASSY
69000408	V6 - HYD MOTOR/GEARBOX
69000409	V6 HI-PRESSURE HYD MOTOR/GEARBOX

#### 3 Gypsy

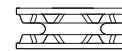

PART NO.	CHAIN DESCRIPTION
68000903	10MM DIN 766, 3/8" ISO G4, LEWMAR 9.5MM (3/8") G40
68000904	11MM SHORT LINK, LEWMAR 12MM G30/G40, 13MM DIN 766, 7/16" G40
68000905	LEWMAR 14MM G30/G40, 14MM DIN 766, RECOMMEND REMOTE CHAIN PIPE VERSION
68000906	1/2" ISO G4, LEWMAR 12MM G30/G40, LEWMAR 1/2" G30/G40

LH = Left Hand, RH = Right Hand, UNI = Universal (symetrical version)

### Switch kit and accessories

#### 4 Circuit breaker

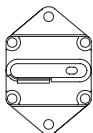

#### 5 Contactor/ control box

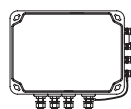

#### 6 Switch and accessories

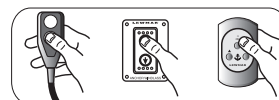

Switch kit and accessories see page 52-60

### 7 Optional Accessories



8-13mm Remote Chain Pipe  
68000024

14-16mm Remote Chain Pipe  
68000037

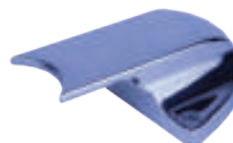

Blank cover and stripper kit  
66000692





## V8 Vertical Windlass

The V8 Vertical Windlass was the first of Lewmar's range of superyacht windlasses. The centre shaft has a support structure built to withstand high loads for larger vessels up to 120 feet. The V8 gypsy is driven by a solid dog clutch that can be easily disconnected for controlled anchor descent via a band brake. The band brake can be operated with a winch handle or remotely by hand wheel. The V8 is available in many options including gypsy drum and gypsy only, both in left- and right-hand configuration and a full range of power options include AC, DC and hydraulic.

- All stainless steel deck unit
- Dog clutch
- A wide range of metric and imperial chain gypsies are available
- Close-coupled or remote band brake options available
- Full range of power options including AC, DC and hydraulic
- Independent capstan operation
- Powered or manual chain release
- W.A.R.P. Drum (Wear and Abrasion Resistant Pattern)
- Left and right-hand versions
- Remote chain pipe version
- For boats up to 33m (108ft)



### V8 Electric Specifications

MODEL	VOLTAGE	MOTOR POWER WATT	MAX PULL		WORKING LOAD LIMIT		MAX LINE SPEED		NORMAL CURRENT DRAW AMP	CIRCUIT BREAKER AMP	WEIGHT	
			KG	LB	KG	LB	M/MIN	FT/MIN			KG	LB
V8 2500W	24	2500	2273	5000	568	1250	24	79	150	200	101	222
V8 3500W	24	3500	2727	6000	682	1500	23	75	200	250	103	227
V8 AC	208		2200	4840	625	1375	15.5	51	12	16	105	231
V8 AC	400		2500	5500	550	1210	19	62	9	10	105	231

### V8 Hydraulic Specifications

MODEL	NORMAL PRESSURE		FLOW RATE		MAX PULL		MAX LINE SPEED		WEIGHT	
	BAR	PSI	L/MIN	US GAL/MIN	KG	LB	M/MIN	FT/MIN	KG	LB
V8 HYD (165CC/REV)	50	735	20-55	5.2-14.3	1818 @ 155 BAR	4000 @ 2278 PSI	18 @ 43 L/MIN	59 @ 11.3 US GAL/MIN	84	185
V8 HYD (230CC/REV)	50	735	20-55	5.2-14.3	2727 @ 155 BAR	6000 @ 2278 PSI	14 @ 40 L/MIN	46 @ 10.6 US GAL/MIN	84	185
V8 HI-P HYD (IN-LINE)	50	735	20-55	5.2-14.3	2727 @ 175 BAR	6000 @ 2572 PSI	21 @ 56 L/MIN	69 @ 14.7 US GAL/MIN	95	209

# I. Windlasses

## V8 Vertical Windlass

### Dimensions Diagram

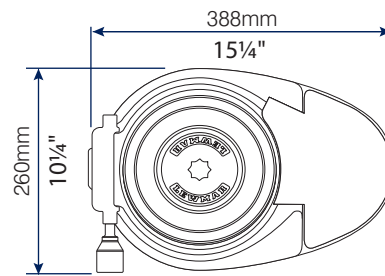
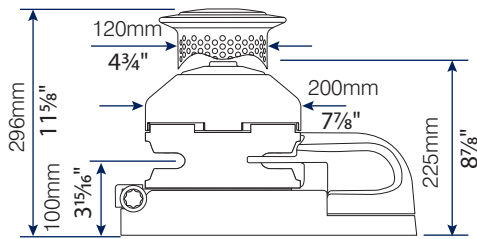

### V8 Part Numbers

#### 1 Deck Unit

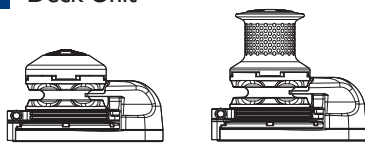

PART NO.	PART NO.	DESCRIPTION
LEFT HAND	RIGHT HAND	
69000377	69000378	V8 DECK UNIT GD, CB
69000379	69000380	V8 DECK UNIT GD, HI-P CB
69000381	69000382	V8 DECK UNIT GO, CB
69000387	69000388	V8 DECK UNIT GO, HI-P CB
69000390	69000391	V8 DECK UNIT GD, RB
69000392	69000393	V8 DECK UNIT GD, HI-P RB
69000394	69000395	V8 DECK UNIT GO, RB
69000396	69000397	V8 DECK UNIT GO, HI-P RB

#### 2 Motor Gearbox

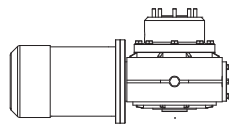

PART NO.	DESCRIPTION
69000383	V8 24V 2.5KW MOTOR/GEARBOX
69000383M	V8 24V 2.5KW M/GEARBOX MIRRORED
69000384	V8 24V 3.5KW MOTOR/GEARBOX
69000384M	V8 24V 3.5KW M/GEARBOX MIRRORED
69000385	V8 HYD MOTOR/GEARBOX TE230
69000386	V8 HYD HP MOTOR GEARBOX HIP ADAN 200
69000416	V8 165CC/REV HYD MOTOR/GEARBOX TE165
69000444	V8 4KW 400V 3 PH AC BRAKED M/GEARBOX
69000444M	V8 4KW 400V AC BRAKED M/GEARBOX MIRRORED
69000445	V8 4KW 208V 3 PH AC BRAKED M/GEARBOX
69000445M	V8 4KW 208V 3 PH AC BRAKED M/GEARBOX MIRRORED

#### 3 Gypsy

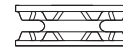

PART NO.	GYPSY KIT	CHAIN DESCRIPTION
68000900	11MM	11 MM DIN 766
68000877	12-13MM	12 MM SHORT LINK, 13 MM DIN 766, 7/16" ISO G4
68000878	14MM	14 MM SHORT LINK, 14 MM DIN 766
68000879	16MM	16 MM SHORT LINK, 16 MM DIN 766
68000880	1/2"	1/2" ISO G4
68000881	14MM STUDLINK	14MM STUDLINK

#### + AC control boxes



PART NO.	VOLTAGE	MOTOR POWER	RATED CURRENT
68000973	400 V	4 KW	9 A
68000974	400 V	5.5 KW	12 A
68000975	400 V	7.5KW	16 A
68000981	200 V	4 KW	16 A
68000982	200 V	5.5 KW	20 A
68000983	200 V	7.5KW	27 A

### Switch kit and accessories

#### 4 Circuit breaker

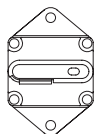

#### 5 Contactor/ control box

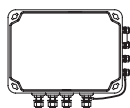

#### 6 Switch and accessories

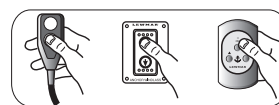

Switch kit and accessories see page 52-60

### Description Abbreviations & Explanations

LH	LEFT HAND ARE MAINLY FOR SINGLE INSTALLS	MIRRORED	MIRROR IMAGE TO ALLOW MOTOR TO BE ON OPPOSITE SIDE OF GEARBOX
HI-P	HIGH-POWER DECK UNIT CAN ONLY BE USED WITH HP HYDRAULIC MOTOR GEARBOX	HP	HIGH-PERFORMANCE INLINE HYDRAULIC DRIVE
CB	CLOSE COUPLED BAND BRAKE INCLUDED. IT IS OPERATED WITH A WINCH HANDLE OR WITH CLOSE COUPLED HANDWHEEL ASSEMBLY 68001023	GD	GYPSY DRUM
RB	REMOTE BAND BRAKE VERSION READY TO ACCEPT THE BRAKE CABLE	GO	GYPSY ONLY

## 7 Optional Accessories

### Blank Cover

Blank cover and stripper kit can be used in installations where the chain pipe cover is not integrated to the windlass.

PART NO.	DESCRIPTION
66000691	BLANK COVER AND STRIPPER KIT

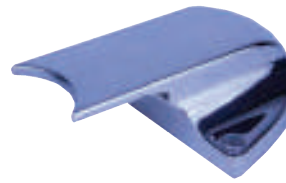

### Remote Chain Pipe

Remote chain pipes are efficient ways to deflect the chain in installation where the chain locker is offset.

PART NO.	DESCRIPTION
68000024	8-13MM REMOTE CHAIN PIPE



### Band Brake Controls



PART NO.	DESCRIPTION
68000897	V8 HORIZONTAL REMOTE BRAKE
68000876	V8 REMOTE BRAKE ASSY
68001023	V8 CLOSED COUPLED HANDWHEEL ASSY

### Brake Cables - For use with remote handwheels

PART NO.	DESCRIPTION
65001687	V8 BRAKE CABLE 800MM (4MM WIRE)
65001688	V8 BRAKE CABLE 1000MM (4MM WIRE)



68001023

# I. Windlasses



## V9/V10/V12 Vertical Windlasses

Offering a full suite of superyacht winches, the V9-V12 range caters for vessels from 95 to 160ft. Lewmar's cutting edge design includes large precision cast component assemblies. The casting allows optimised strength through FEA design, whilst offering significant weight saving over solid components.

- All stainless steel deck unit
- All sizes are available as gypsy only and gypsy drum in left hand, right hand and remote chain pipe configurations
- Full range of power options including AC, DC and hydraulic
- Independent capstan operation
- Powered or manual chain release
- W.A.R.P. Drum (Wear and Abrasion Resistant Pattern)
- A wide range of metric and imperial chain gypsies are available including 22mm Studlink
- For boats up to 50m (164ft)

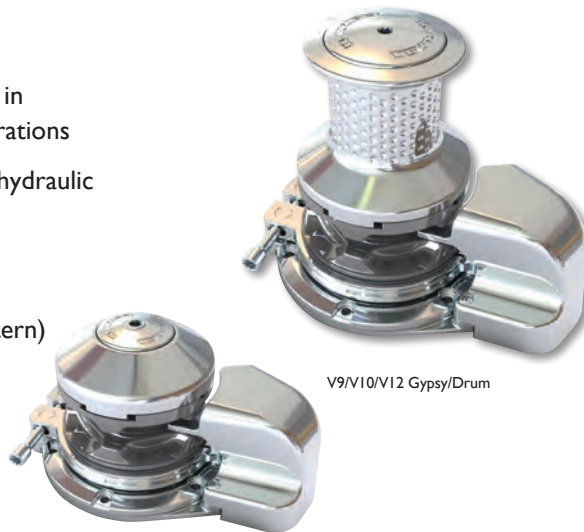

V9/V10/V12 Gypsy/Drum



V9/V10/V12



V10/V12 Only

### V9/V10/V12 Electric Specifications

V9/V10/V12 Gypsy Only

MODEL	MOTOR POWER WATT	MAX PULL		WORKING LOAD LIMIT		MAX LINE SPEED		NORMAL CURRENT DRAW AMP	CIRCUIT BREAKER AMP	WEIGHT	
		KG	LB	KG	LB	M/MIN	FT/MIN			KG	LB
V9 400V AC	4000	2250	4950	1125	2475	21	69	11	12	183	403
V9 208V AC	4000	2250	4950	1125	2475	21	69	13	14	183	403
V9 400V AC	5500	3182	7000	1591	3500	22	72	15	16	207	455
V10 400V AC	5500	4000	8800	2000	4400	18	59	12	13	301	662
V10 208V AC	5500	4000	8800	2000	4400	18	59	16	20	301	662
V12 400V AC	7500	5000	11000	2500	5500	20	66	15	16	357	785
V12 208V AC	7500	5000	11000	2500	5500	20	66	24	32	357	785

### V9/V10/V12 Hydraulic Specifications

MODEL	GEARBOX	MAX PRESSURE		FLOW RATE		MAX PULL		WORKING LOAD		MAX LINE SPEED		WEIGHT	
		BAR	PSI	L/MIN	US GAL/MIN	KG	LB	KG	LB	M/MIN	FT/MIN	KG	LB
V9 - 300 CC/REV		180	2646	20-60	5.2-15.6	3000	6600	1500	3300	30	96	153	337
V9 - 230 CC/REV		180	2646	20-60	5.2-15.6	3000	6600	1500	3300	33	108	150	330
V10 - 500 CC/REV	5:1	155	2279	30-60	7.8-15.6	4000	8800	2000	4400	8-16	26-52	187	411
V12 - 250 CC/REV	13.5:1	155	2279	30-80	7.8-20.8	5000	11000	2500	5500	6-17	20-56	204	449

## V9/V10/V12 Vertical Windlasses

### V9 Dimensions Diagram

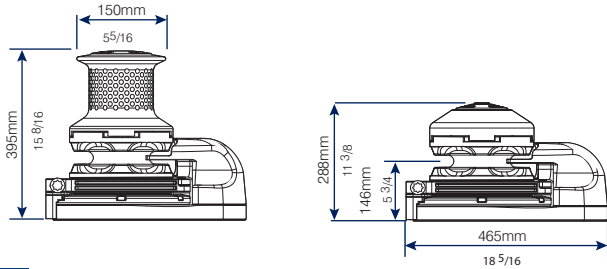

### V10/12 Dimensions Diagram

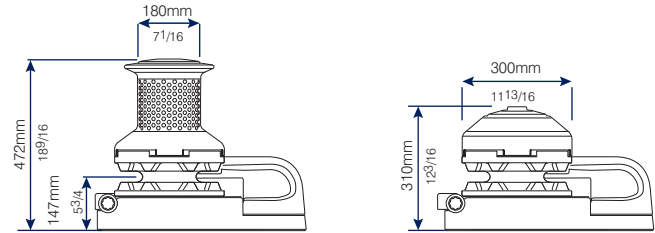

#### 1 Deck Unit

PART NO.	DESCRIPTION
69000460	V9 DECK UNIT LH GD
69000461	V9 DECK UNIT RH GD
69000462	V9 DECK UNIT UNI GD
69000463	V9 DECK UNIT LH GO
69000464	V9 DECK UNIT RH GO
69000465	V9 DECK UNIT UNI GO

LH = LEFT HAND, RH = RIGHT HAND, UNI = UNIVERSAL (SYMMETRICAL VERSION), GO = GYPSY ONLY, GD = GYPSY DRUM

PART NO.	DESCRIPTION
69000418	V10/12 Gd LH DECK UNIT
69000419	V10/12 Gd RH DECK UNIT
69000421	V10/12 Gd UNI PIPE DECK UNIT
69000422	V10/12 Go LH DECK UNIT
69000423	V10/12 Go RH DECK UNIT
69000424	V10/12 Go UNI PIPE DECK UNIT

#### 2 Motor Gearbox

PART NO.	DESCRIPTION
69000469	V9 HYDRAULIC MOTOR/GEARBOX 230 CC/REV
69000468	V9 HYDRAULIC MOTOR/GEARBOX 300 CC/REV
69000467	V9 208V AC 4KW DRIVE WITH BRAKE *
69000466	V9 400V AC 4KW DRIVE WITH BRAKE *
69000471	V9 400V AC 5.5KW DRIVE WITH BRAKE *

\* MIRRORED VERSION AVAILABLE ADD M AT THE END OF THE PART NO

PART NO.	DESCRIPTION
69000427	V10 HYDRAULIC DRIVE WITH BRAKE
69000448	V10 208V 5.5KW DRIVE WITH BRAKE
69000447	V10 400V 5.5 KW DRIVE WITH BRAKE
69000428	V12 HYDRAULIC DRIVE WITH BRAKE
69000450	V10 208V 7.5KW DRIVE WITH BRAKE
69000449	V12 400V 7.5 KW DRIVE WITH BRAKE

#### 3 Gypsy

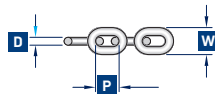

PART NO.	CHAIN DESCRIPTION	D		P		W	
		MM	IN	MM	IN	MM	IN
V9							
66000738	12.5MM STUDLINK	12.5	0.492	50	1.969	45	1.772
66000775	14MM SHORTLINK GYPSY KIT	14	0.551	41	1.614	50	1.969
66000721	14MM STUDLINK	14	0.551	56	2.205	50.4	1.984
66000722	16MM STUDLINK	16	0.630	64	2.520	57.6	2.268
66000723	16MM SHORTLINK/DIN766	16	0.630	48	1.890	56	2.205
66000724	17.5MM STUDLINK	17.5	0.689	70	2.756	63	2.480
66000725	18MM DIN 766	18	0.709	50	1.969	65	2.559

PART NO.	CHAIN DESCRIPTION	D		P		W	
		MM	IN	MM	IN	MM	IN
V10/12							
68000944	15MM STUDLINK	16	0.630	64	2.520	57.6	2.268
68000946	17.5MM STUDLINK	17.5	0.689	70	2.756	63	2.480
68000943	19MM STUDLINK	19	0.748	76	2.992	68.4	2.693
68000932	20.5MM STUDLINK	20.5	0.807	82	3.228	73.8	2.906
68000945	22MM STUDLINK - V12 REMOTE HAWSE ONLY	22	0.866	88	3.465	79.2	3.118

#### + AC control boxes



PART NO.	VOLTAGE	MOTOR POWER	RATED CURRENT
68000973	400 V	4 KW	9 A
68000974	400 V	5.5 KW	12 A
68000975	400 V	7.5KW	16 A
68000981	200 V	4 KW	16 A
68000982	200 V	5.5 KW	20 A
68000983	200 V	7.5KW	27 A

#### 7 Optional Accessories

- Remote Hand wheel
- 68001025** - Suitable for V9
- 68000948** - Suitable for V10/V12
- Custom brake control solutions are also available



#### Switch kit and accessories

##### 4 Circuit breaker

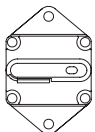

##### 5 Contactor/ control box

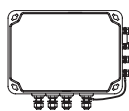

##### 6 Switch and accessories

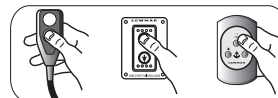

Switch kit and accessories see page 52-60

# I. Windlasses



## VI4/16 Vertical Windlasses

The VI4/16 is Lewmar's most powerful windlass for the superyacht market. Scaling our engineering principles to massive proportions, the VI4/16 is immensely strong, reliable and suited to large-scale applications. Left- or right-hand configurations available with remote brake bands operated by wheel or winch handle.

- All 316 stainless steel drum and base.
- Gypsies for 19mm, 22mm, 24mm & 26mm studlink chain
- Integral chain stripper
- Remote hawse pipe with and without roller
- Gypsy Drum and Gypsy Only versions. Drum to accept 3 full turns of 50mm line
- Hydraulic and A.C. input
- Band brake operation via direct close coupled or remote hand wheel, with optional positions
- Handle deck thicknesses of up to 250mm
- Chain counter pickup standard



### VI4/16 Electric Specifications

MODEL	MOTOR POWER WATT	MAX PULL		WORKING LOAD LIMIT		MAX LINE SPEED		WEIGHT	
		KG	LB	KG	LB	M/MIN	FT/MIN	KG	LB
V14 400V AC	9.2	6000	13200	3000	6600	23.3	76.5	628	1383
V14 208V AC	9.2	6000	13200	3000	6600	23.3	76.5	628	1383
V16 400V AC	11	7000	15400	3500	7700	27.5	90.22	646	1420
V16 208V AC	11	7000	15400	3500	7700	27.5	90.22	646	1420

### VI4/16 Hydraulic Specifications

MODEL	GEARBOX	MAX PRESSURE		FLOW RATE		MAX PULL		WORKING LOAD		MAX. LINE SPEED		WEIGHT	
		BAR	PSI	L/MIN	US GAL/MIN	KG	LB	KG	LB	M/MIN	FT/MIN	KG	LB
V14 - 400 CC/REV	13.5 : 1	160	2352	90	24	6500	14300	3250	7150	19	62	329	725
V16 - 300 CC/REV	13.5 : 1	160	2352	90	24	7300	16060	3650	8030	17	56	328	722.5

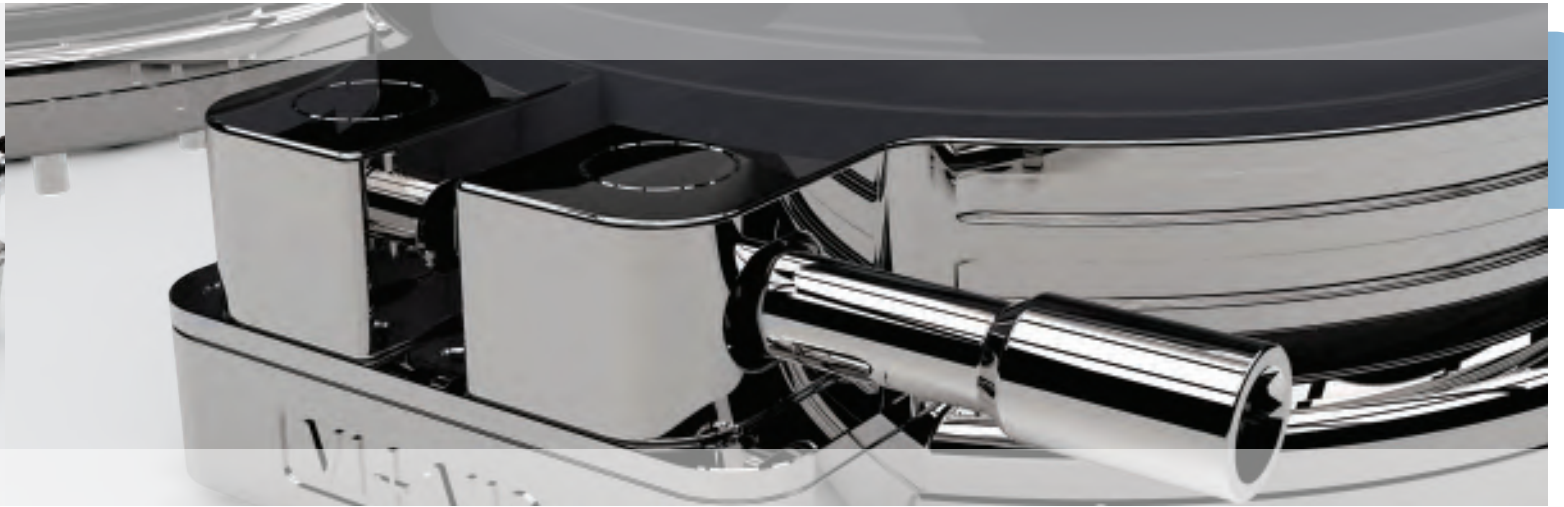

### V14/16 Dimensions Diagram

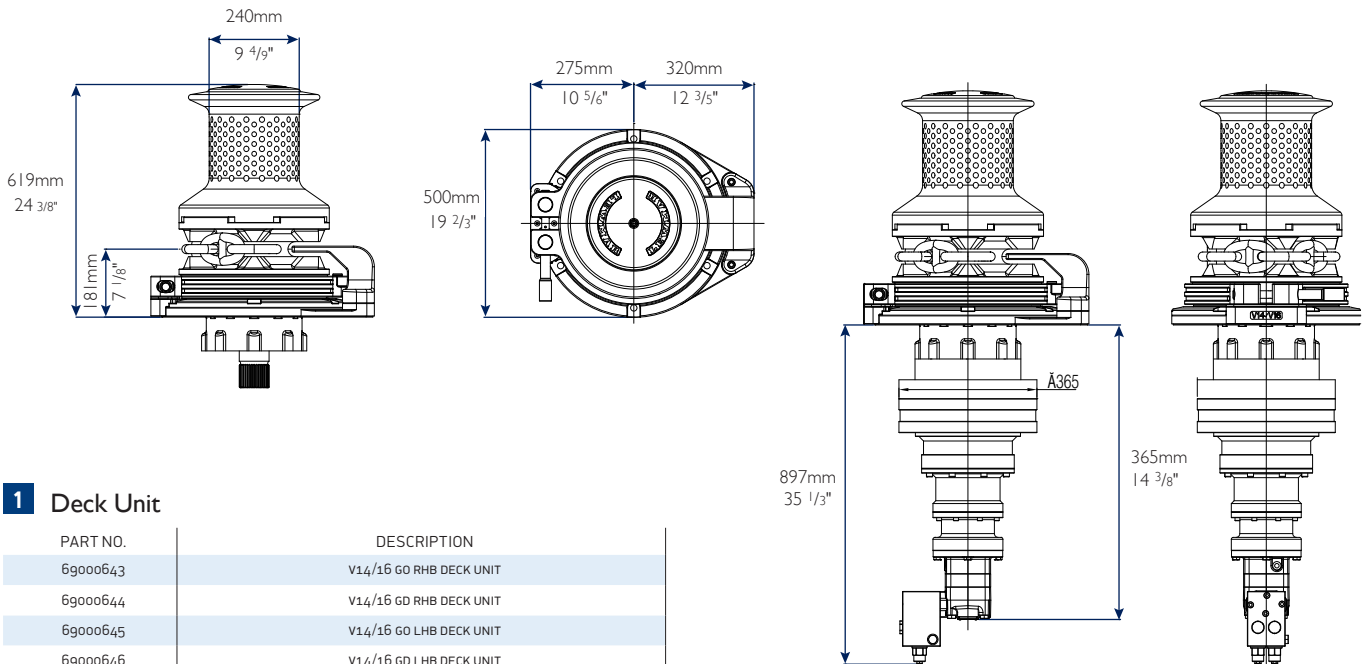

#### 1 Deck Unit

PART NO.	DESCRIPTION
69000643	V14/16 GO RHB DECK UNIT
69000644	V14/16 GD RHB DECK UNIT
69000645	V14/16 GO LHB DECK UNIT
69000646	V14/16 GD LHB DECK UNIT

LH = LEFT HAND, RH = RIGHT HAND, UNI = UNIVERSAL (SYMMETRICAL VERSION), GO = GYPSY ONLY, GD = GYPSY DRUM

#### 2 Motor Gearbox

PART NO.	DESCRIPTION
69000641	V14 HYDRAULIC MOTOR / GEARBOX
69000642	V16 HYDRAULIC MOTOR / GEARBOX

\* MIRRORED VERSION AVAILABLE ADD M AT THE END OF THE PART NO

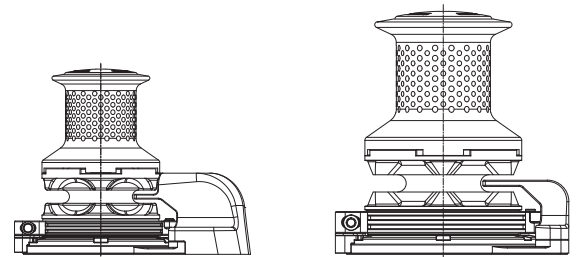

#### 3 Gypsy

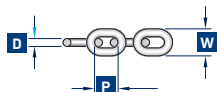

PART NO.	CHAIN DESCRIPTION	D		P		W	
		MM	IN	MM	IN	MM	IN
68001165	19MM	19	0.75	76	2.99	68.4	2.69
68001166	22MM	22	0.86	88	3.46	79.2	3.11
68001167	24MM	24	0.94	96	3.77	86.4	3.4
68001168	26MM	26	1.02	104	4.09	93.6	3.68

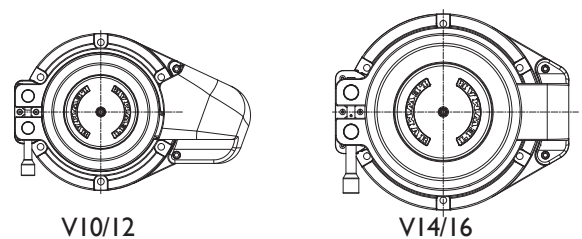

# I. Windlasses



## HXI Horizontal Windlass

The HX range utilises a cast alloy and composite casing combined with a high-power drive train - using the latest inline motors and epicyclical gearboxes - resulting in a strong reliable design. HX features a strong and durable anodized aluminium chassis resulting in a strong, reliable design.

- Motor range 500W & 800W in 12V
- High efficiency epicyclical gearbox
- Sealed waterproof unit requires minimum maintenance
- Anodized aluminium chassis with a durable polymer cover
- IP67 rated as standard
- Quiet operation
- 2 gypsy models available to suit calibrated chain: 6/7mm (1/4"), 8mm



### HXI Specifications

MODEL	MAX PULL		WORKING LOAD LIMIT		MAX LINE SPEED		NORMAL CURRENT DRAW AMP	CIRCUIT BREAKER AMP	APPROX WEIGHT GO		APPROX WEIGHT GD	
	KG	LB	KG	LB	M/MIN	FT/MIN			KG	LBS	KG	LB
500W	700	1543	175	383	20	60	75	50	9	20	9.5	21
800W	1065	2348	266	586	21	63	105	70	9	20	9.5	21

Windlass performance values are tested using +/-10% 12 voltage simulating the operation parameters of an installed battery system of a boat



## Dimensions Diagram

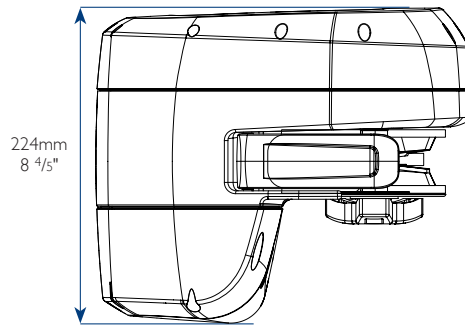
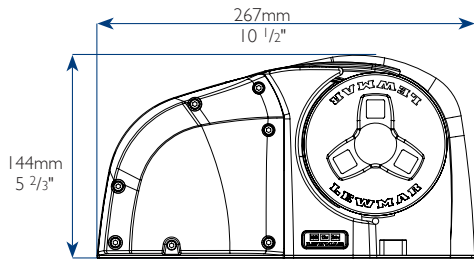

### HX1 Standard Windlass Kits

PART NUMBER	DESCRIPTION
69140001	HX1 G0 500 6/7MM 1/4" STD KIT
69140002	HX1 G0 800 6/7MM 1/4" STD KIT
69140003	HX1 G0 500 8MM 5/16" STD KIT
69140004	HX1 G0 800 8MM 5/16" STD KIT
69140005	HX1 GD 500 6/7MM 1/4" STD KIT
69140006	HX1 GD 800 6/7MM 1/4" STD KIT
69140007	HX1 GD 500 8MM 5/16" STD KIT
69140008	HX1 GD 800 8MM 5/16" STD KIT
69140009	HX1 500 GF 6/7MM STD KIT
69140010	HX1 800 GF 6/7MM STD KIT
69140011	HX1 500 GF 8MM STD KIT
69140012	HX1 800 GF 8MM STD KIT

HX1 Basic windlass kit includes HX1 with intergrated motor gearbox, solenoid and gypsy

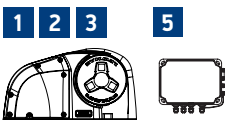

### HX1 Extended Windlass Kits

PART NUMBER	DESCRIPTION
69140030	HX1 G0 500 6/7MM 1/4" EXT D KIT
69140031	HX1 G0 800 6/7MM 1/4" EXT D KIT
69140032	HX1 G0 500 8MM 5/16" EXT D KIT
69140033	HX1 G0 800 8MM 5/16" EXT D KIT
69140034	HX1 GD 500 6/7MM 1/4" EXT D KIT
69140035	HX1 GD 800 6/7MM 1/4" EXT D KIT
69140036	HX1 GD 500 8MM 5/16" EXT D KIT
69140037	HX1 GD 800 8MM 5/16" EXT D KIT
69140038	HX1 500 GF 6/7MM EXT D KIT
69140039	HX1 800 GF 6/7MM EXT D KIT
69140040	HX1 500 GF 8MM EXT D KIT
69140041	HX1 800 GF 8MM EXT D KIT

Extended windlass kit includes deck unit, motor gearbox, solenoid, gypsy, rocker switch and circuit breaker

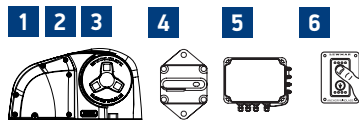

Switch kit and accessories see page 52-60

## 7 Optional Accessories

### HX1 Free Fall Conversion Kit

Upgrade your Lewmar HX1 with the Lewmar HX1 Freefall Conversion Kit. An innovative design allows the windlass to automatically engage and disengage the gypsy clutch when needed, allowing great flexibility of anchoring possibilities.

The conversion kit allows simple retrofitting of the freefall mechanism.



PART NO.  
66140008

# I. Windlasses



## Pro-Series + Pro-Fish Horizontal Windlasses

The Pro-Series Windlass is the ideal horizontal unit for on-deck installation. A beautiful stainless steel case combines robustness and strength. On the Pro-Fish edition, the automatic freefall mechanism means access to the windlass is not required to drop or retrieve anchor. The gypsy has been specially designed to suit leaded lines up to 16mm in diameter and an optimised control arm. The new Pro-Guard plate prevents the rope from jumping out of the windlass or snagging during operation.

- All stainless design
- Automatic freefall mechanism (Pro-Fish only)
- Manual emergency recovery equipped – all you need is a common 1/2" socket wrench
- Maximum pulling power: 320kg (700 lb) for the 700 and 454kg (1,000 lb) for the 1000
- 5-year warranty
- For boats up to 12m (38ft)
- Free Fall conversion kits
- DIY ready

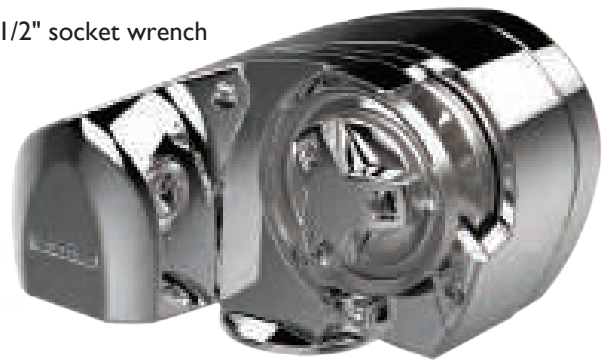

### Pro-Fish Features

- Redesigned control arm features higher spring tension and modified profile to improve performance
- Closed cell neoprene gasket protects internals
- Unique Pro-Guard feature prevents rope jump and snags
- New gypsy designed specifically for up to 16mm leaded anchor rodes

### Pro-Series/Fish Specifications

MODEL	MAX.CHAIN		MOTOR SUPPLY VOLTAGE	MOTOR POWER WATT	MAXIMUM PULL		WORKING LOAD LIMIT		MAXIMUM LINE SPEED		NORMAL CURRENT DRAW AMP	CIRCUIT BREAKER AMP	WEIGHT	
	MM	IN			KG	LB	KG	LB	M/MIN	FT/MIN			KG	LB
PRO-SERIES 700	7	1/4	12	500	320	700	79	175	32	105	35	50	8.5	19
PRO-SERIES 1000	8	5/16	12	700	454	1000	114	250	32	105	50	70	9.5	21
PRO-FISH 700	7	1/4	12	500	320	700	79	175	32	105	35	50	8.5	19
PRO-FISH 1000	8	5/16	12	700	454	1000	114	250	32	105	50	70	9.5	21

## Pro-Series + Pro-Fish Horizontal Windlasses

### Dimensions Diagram

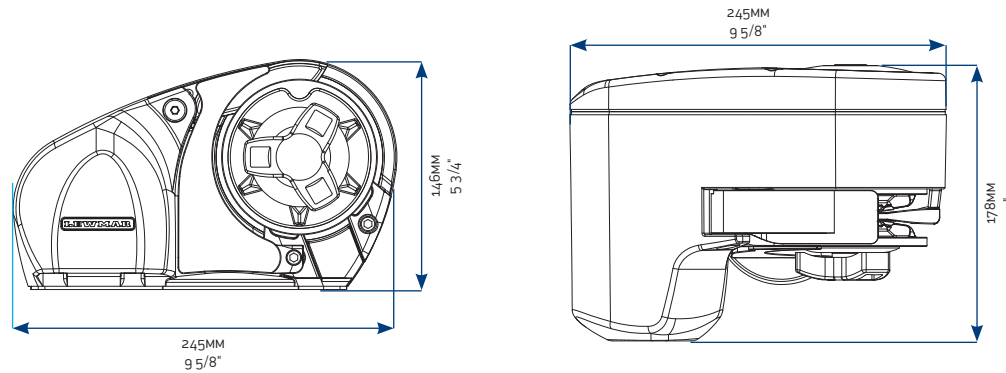

### Pro-Series Kit

PART NO.	DESCRIPTION	GYPSY SPECIFICATIONS	
		CHAIN	ROPE
6656011967-310	PRO-SERIES 700 KIT	6MM DIN 766, 7MM DIN 766, 1/4" ISO G4, 1/4" BBB	12MM (1/2") 3-STRAND AND 8-PLAIT
6657011967-311	PRO-SERIES 1000, 6-7MM (1/4") KIT	6MM DIN 766, 7MM DIN 766, 1/4" ISO G4, 1/4" BBB	12MM (1/2") 3-STRAND AND 8-PLAIT
6657011198-311	PRO-SERIES 1000, 8MM (5/16") KIT	8MM DIN 766, 5/16" BBB, 8MM ISO 4565	14-16MM (9/16-5/8") 3-STRAND AND 8-PLAIT (5/8 ONLY)
6657011108-102	PRO-SERIES 1000, 5/16" G40 KIT (US ONLY)	5/16" G40	14-16MM (9/16-5/8") 3-STRAND AND 8-PLAIT (5/8 ONLY)

Kits include: Windlass, base gasket seal, fast-mounting studs, installation wrench, circuit breaker, dual-direction solenoid and rocker switch.

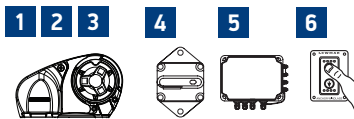

### Pro-Fish Windlass Kit

PART NO.	DESCRIPTION	GYPSY SPECIFICATIONS	
		CHAIN	ROPE
6656211967-310	PRO-FISH 700 KIT	6MM DIN 766, 7MM DIN 766, 1/4" ISO G4, 1/4" BBB	12MM (1/2") 3-STRAND AND 8-PLAIT
6656411198-311	PRO-FISH 1000 KIT	8MM DIN 766, 5/16" BBB, 8MM ISO 4565	14-16MM (9/16-5/8") 3-STRAND AND 8-PLAIT (5/8 ONLY)
6656411199-311	PRO-FISH PB	14-16 MM (9/16-5/8") LEAD-CORE LINE	
6657011108-102	PRO-SERIES 1000, 5/16" G40 KIT (US ONLY)	5/16" G40	14-16MM (9/16-5/8") 3-STRAND AND 8-PLAIT (5/8 ONLY)

Kits include: Windlass, base gasket seal, fast-mounting studs, installation wrench, circuit breaker, dual-direction solenoid and rocker switch

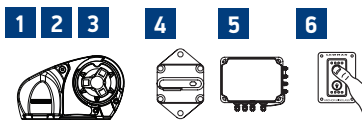

### 7 Optional Accessories

#### Pro-Fish Conversion Kit

Converts Pro-Series to Pro-Fish



PART NO.	DESCRIPTION
66000616	CONVERSION KIT

#### Pro-Series/Fish Rope Guard and Control Arm Upgrade Kit

Compatible with all versions of Pro-Series and Pro-Fish units. However, windlasses fitted with a Ø118mm RC860 gypsy will need to replace the gypsy.

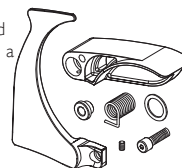

PART NO.	DESCRIPTION
66000766	PRO-SERIES/FISH ROPE GUARD AND CONTROL ARM UPGRADE KIT

#### Pro-Fish PB Ledged Rope Gypsy Kit

Suits 14-16mm lead-core line

PART NO.	DESCRIPTION
66000768	PRO-FISH PB GYPSY KIT

# I. Windlasses



## Pro-Sport Horizontal Windlass

Lewmar's Pro-Sport windlass is designed as an economical package for rope and chain applications, without compromising quality or performance. Pro-Sport is designed around a highly efficient spur gearbox, using smaller, more powerful permanent magnet motors. Its rugged aluminium centre case and durable composite side covers make Pro-Sport the perfect choice. Complete with push-button control, anchoring has never been easier:

- Low power consumption / current draw
- Dual direction powered operation
- Maximum pulling power: 250kg (550lb)
- Convenient above deck installation
- 3 year warranty
- For boats up to 12m (40ft)
- Manual freefall
- DIY ready



### Pro-Sport 550 Windlass Kit Specifications

PART NUMBER	CHAIN DESCRIPTION	ROPE DESCRIPTION			MOTOR SUPPLY	MOTOR POWER	MAXIMUM PULL		MAXIMUM LINE SPEED		WORKING LOAD LIMIT		NORMAL CURRENT DRAW	WEIGHT		CIRCUIT BREAKER
		MM	IN		VOLTAGE	WATT	KG	LB	M/MIN.	FT/MIN.	KG	LB	AMP	KG	LB	
6656811967-303	6MM DIN766, 1/4" ISO G4, 1/4" BBB, 7MM DIN 766	12MM	1/2	3-STRAND AND 8-PLAIT	12	150	250	550	30	98	62.5	137.5	20	6.5	14	25

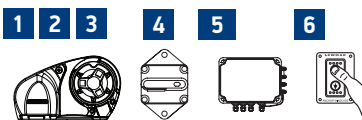

Kit includes: windlass, base gasket seal, fast mounting studs, installation wrench, contactor (68000939), guarded rocker switch (68000593) and circuit breaker

### Dimensions Diagram

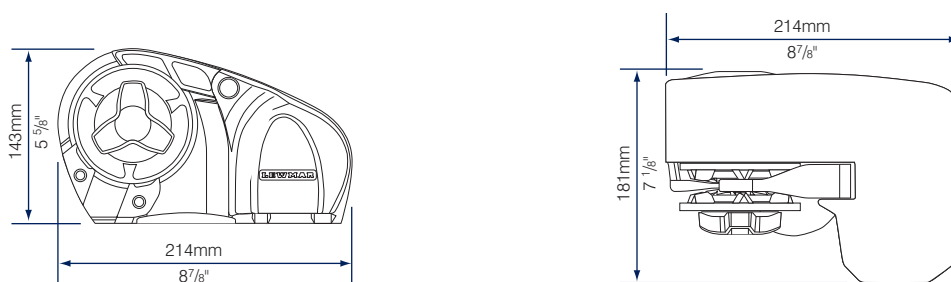



## H-Series

The stylish, horizontal H-Series Windlass uses reliable worm gearbox technology. The integral contactor simplifies wiring and is protected by a durable maincase. The unit's waterproof seal requires minimum maintenance, and since you can install it in one piece, getting started is quick and easy.

- Stainless steel warping drum with unique W.A.R.P. (Wear and Abrasion Reduction Pattern) finish
- Robust horizontal worm motor-gearbox for reliable performance
- Integral contactor protected by maincase
- Sealed waterproof unit requires minimum maintenance
- Aluminium and composite maincase for reduced weight



### H2 & H3 Specifications

PART NUMBER GYPSY ONLY	PART NUMBER GYPSY/DRUM	MODEL	MOTOR SUPPLY VOLTAGE	GYPSY NO.	MOTOR POWER WATT	MAXIMUM PULL		MAXIMUM LINE SPEED		WORKING LOAD LIMIT		NORMAL CURRENT DRAW AMP	NORMAL LINE SPEED		WEIGHT GYPSY ONLY		WEIGHT GYPSY/DRUM		CIRCUIT BREAKER AMP
						KG	LB	M/MIN	FT/MIN	KG	LB		M	FT	KG	LB	KG	LB	
69600533	69600537	H2	12	505	700	650	1433	21	69	163	358	80	17	56	21.5	47	23.5	52	90
69600534	69600538	H2	12	506	700	650	1433	21	69	163	358	80	17	56	21.5	47	23.5	52	90
69600541	69600545	H3	12	505	1000	890	1962	28	92	215	475	85	18	59	23.5	52	25.5	56	110
69600542	69600546	H3	12	506	1000	890	1962	28	92	215	475	85	18	59	23.5	52	25.5	56	110
69600544	69600548	H3	24	506	1000	1020	2248	30	98	243	535	60	20	66	23.5	52	25.5	56	90

### H2 & H3 Gypsy Specifications

PART NUMBER	GYPSY NUMBER	SIZE MM	CHAIN DESCRIPTION	ROPE DESCRIPTION		
				MM	IN	
66000007	505	8	5/16" BB, 5/16" ISO G4, 8MM DIN 766, 8MM ISO 4565	14-16	9/16-5/8	3-STRAND AND 8-PLAIT (5/8 ONLY)
66000006	506	10	3/8" BBB, 10MM DIN 766, LEWMAR 9.5 G40	14-16	9/16-5/8	3-STRAND AND 8-PLAIT (5/8 ONLY)

Kits include: Built-in-dual-direction contactor, breaker and rocker switch

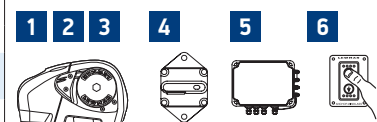

### Dimensions Diagram

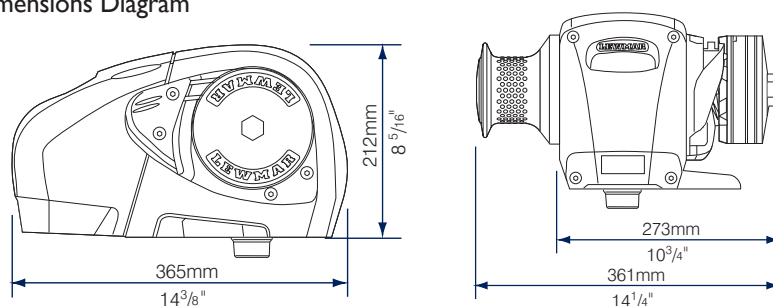

### 7 Optional Accessories Manual Recovery Kit

Available on the H2/H3 as an optional extra, it remains fitted to the unit for user convenience

PART NO.	DESCRIPTION
66840045	M/R KIT H2/H3

# I. Windlasses



## C Series Capstans

Lewmar's C Series Capstans provide effortless rope control at the press of a footswitch. The W.A.R.P. (Wear and Abrasion Resistant Pattern) finished drum optimises performance and reduces rope wear by up to 30%. Stainless steel components combine strength, corrosion resistance and durability with a beautiful polished finish. Installation of the C3 is quick and simple as it is fastened entirely from above deck.

- Beautifully crafted stainless steel components ensure enduring strength and performance
- W.A.R.P. finish drum - unique Wear and Abrasion Resistant Pattern reduces rope wear by 30%
- C3 offers quick, easy on-deck installation, requiring only one person
- C4–C10s have worm gearbox-inherent anti-runback characteristics acting as a mechanical brake



### Capstan Selection Guide

MODEL	BOAT LENGTH OVERALL									
	6 M 20 FT	12.2 M 40 FT	18.3 M 60 FT	24.4 M 80 FT	30.5 M 100 FT	36.6 M 120 FT	42.7 M 140 FT	48.8 M 160 FT	55 M 180 FT	
VXC	[Lighter shading]									
C3	[Lighter shading]									
C4	[Lighter shading]									
C5	[Lighter shading]									
C6	[Lighter shading]									
C10	[Lighter shading]									
C12	[Lighter shading]									

Lighter shading represents the upper limit of model. If in doubt, move up a model.

### C Series Capstan Electric Specifications

DESCRIPTION	MOTOR POWER WATT	MAXIMUM PULL		WORKING LOAD LIMIT		MAXIMUM LINE SPEED		NORMAL CURRENT DRAW AMP	CIRCUIT BREAKER AMP	WEIGHT	
		KG	LB	KG	LB	M/MIN	FT/MIN			KG	LB
VXC	800	700	1543	175	385	21	63	58	70	7	15
C3 - 12V	1000	750	1650	188	414	12	39	65	70	12	26
C3 - 24V	1000	850	1870	213	470	12	39	40	50	12	26
C4 - 12V	1600	1250	2750	313	690	25	82	125	150	25	55
C4 - 24V	2000	1500	3300	375	827	27	89	70	110	25	55
C4 - 400 AC	2200	1500	3300	375	827	12.5	41	5	6	36	80
C5 - 12V	2000	1450	3190	363	800	27	89	120	150	27.5	60
C5 - 24V	2000	1600	3520	400	882	29	97	60	110	27.5	60
C6 - 24V	2000	1540	3388	770	1698	40	131	90	-	30	66
C6 - 400V AC	3000	1600	3520	800	1760	14	46	7.4	-	44	97
C10 - 400V AC	4000	2400	5280	1200	2640	20	66	9	10	107	236

## C-Series Capstans

### C Series Capstan Hydraulic Specifications

MODEL	NORMAL PRESSURE		FLOW RATE		MAX. PULL		MAX. LINE SPEED	
	BAR	PSI	L/MIN	US GAL/MIN	KG	LB	M/MIN	FT/MIN
C4/5 HYDRAULIC	175	2537	10-40	2.6-10.6	1100 AT 14 BAR	2400 AT 203 PSI	21 AT 40L/MIN	69 AT 10.6 US GAL/MIN
C6 HYDRAULIC	175	2573	10-60	2.6-15.8	1600	3520	8 TO 30	26 TO 98
C10 (200 CC/REV)	175	2573	20-55	5.2-14.3	2420	5324	8-23	26-75
C12 (250 CC/REV) 13.5:1 G/BOX	155	2279	30-80	7.8-20.8	5000	11000	6-17	20-56

### C3 Dimensions Diagram

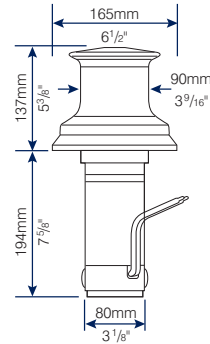

C3 Deck Unit and Motor Gearbox Assembly

### C3 Capstan Kits

PART NO.	DESCRIPTION
6630331312	C3 - 12V DECK UNIT @ MOTOR GEARBOX ASSEMBLY
6630332312	C3 - 24V DECK UNIT @ MOTOR GEARBOX ASSEMBLY

## C4/5/6/10/12 Capstans

### 1 Deck Unit

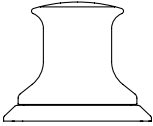

PART NO.	DESCRIPTION
66810032	C4/5 DECK UNIT
69000411	C6 DECK UNIT
69000453	C10/12 DECK UNIT

### 2 Motor Gearbox

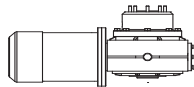

PART NO.	DESCRIPTION
68000534	C4 - 12V MOTOR GEARBOX
68000535	C4 - 24V MOTOR GEARBOX
68000901	C4 - 400V AC
66810011	C5 - 12V MOTOR GEARBOX
66810012	C5 - 24V MOTOR GEARBOX
68000294	C4/5 HYDRAULIC
69000414	C6 - 24V MOTOR GEARBOX
69000496	C6 - 400V AC
69000415	C6 HYDRAULIC
69000491	C10 4KW, 400V AC
69000456	C10 HYDRAULIC
69000458	C12 HYDRAULIC

### 3 Circuit Breakers

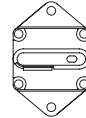

PART NO.	DESCRIPTION
68000350	CIRCUIT BREAKER 110A
68000351	CIRCUIT BREAKER 150A

### 4 Contactor

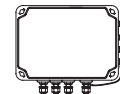

PART NO.	DESCRIPTION
SEALED CONTACTORS	
68000933	SINGLE 12V
68000934	SINGLE 24V
CONTACTORS IN BOXES	
18000301	SINGLE 12V
18000302	SINGLE 24V
PRE-WIRED CONTACTORS IN BOXES WITH FUSE	
68000919	SINGLE 12V
68000920	SINGLE 24V

Suitable for C3, C4, C5 and C6

### + AC control boxes

Suitable for C4, C5, C6 and C10



PART NO.	VOLTAGE	MOTOR POWER	RATED CURRENT
68000976	400 V	2.2 KW	5.5 A
68000977	400 V	3 KW	7 A
68000978	400 V	4KW	9 A
68000979	400 V	5.5 KW	12 A
68000980	400 V	7.5 KW	16 A

PART NO.	VOLTAGE	MOTOR POWER	RATED CURRENT
68000984	200 V	2.2 KW	9.5 A
68000985	200 V	3 KW	12 A
68000986	200 V	4KW	16 A
68000987	200 V	5.5 KW	20 A
68000988	200 V	7.5 KW	27 A

## Dimensions Diagram

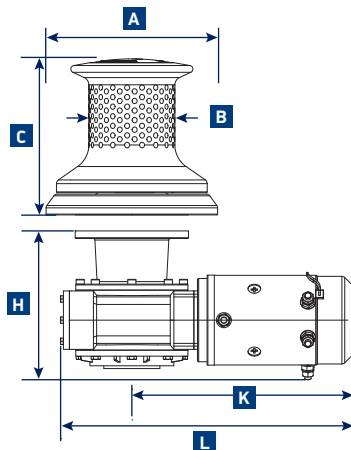

### Above deck dimensions

MODEL	A		B		C	
	MM	IN	MM	IN	MM	IN
C4/5	215	8 1/2	108	4 1/4	196	7 3/4
C6	230	9 1/16	130	5 1/16	219	8 5/8
C10/12	340	13 3/8	180	7	293	11 1/2

### Below deck dimensions

PART NO	MOTOR/GEARBOX	L		K		H	
		MM	IN	MM	IN	MM	IN
68000534	C4 12V	363	14 1/4	278	10 7/8	168	6 2/3
68000535	C4 24V	363	14 1/4	278	10 7/8	168	6 2/3
68000901	C4 400V AC	489	19 1/4	405	15 9/16	201	7 7/8
66810011	C5 12V	390	15 1/3	298	11 2/3	173	6 3/4
66810012	C5 24V	390	15 1/3	298	11 2/3	173	6 3/4
68000294	C4/C5 HYD.	319	12 9/16	235	9 1/4	179	7
69000414	C6 24V	400	15 3/4	299	11 3/4	172	6 5/8
69000491	C10 400V AC	697	27 7/16	555	21 7/8	263	10 1/4

# I. Windlasses



## Captive Reel Windlass CRW400

Lewmar's CRW400 windlass represents a step-change in engineering and design for small boat windlasses. Built around a stainless steel chassis with composite bearing technology and a robust UV-stabilised ABS shell, the CRW400 is salt-water resistant and suitable for boats up to 30ft. Lewmar's unique "level wind" feature ensures that the rode is always stowed neatly on the drum, ensuring tangle-free anchoring and maximum stowage capacity every time. In addition, the windlass features load detection, allowing effective "drift" fishing to be performed. An auto-stop is also included, ensuring a safe number of wraps remain on the drum when anchoring in deep water. An integrated switch is fitted to the rear of the housing, or optional remote controls can be fitted. A clear window means that correct functioning of the windlass can be observed, with no risk of trapping fingers or clothing in the winding drum.

- Rode stowage without the need for a locker
- Optional remote operation - can be deployed and retrieved from the helm as well as the unit
- Self locking – no need for cleat or chain stopper
- High-quality materials and construction
- Level-wind technology prevents spooled line bunching
- All stainless steel 316 chassis / ABS UV-stabilised case



Full UV-stabilised ABS housing incorporates clear viewing window, IP67-rated switchgear and integrated protected electronics housing.



Manufactured in robust acetal, a compact worm and wheel gear system powers the rode feeder arm, thereby neatly laying the rode on the drum.



The composite rode feeder arm includes a sprung load-detecting device. This prevents the unit from paying-out when the line is slack.



Heavy-duty gears transfer the power of the 400W integrated motor-gearbox via the main shaft to the feeder arm mechanism.

### Captive Reel Windlass Specifications

PART NO	MOTOR POWER	MAX LINE SPEED		NORMAL CURRENT DRAW	MAX ANCHOR WEIGHT		ROPE TYPE	LENGTH		DIMENSIONS			
	WATT	M/MIN	FT/MIN	AMP	KG	LB	ROPE ONLY MAX DIMS	MM	IN	WIDTH		HEIGHT	
										MM	IN	MM	IN
66g10441	400	25	82	15	16	40	35M (115FT) OF 6MM (1/4")	365	14 3/8	303	11 15/16	188	7 2/5





## S900 & S2000 Stern Windlass

Lewmar's stern windlass range is designed specifically to suit the growing trend of stern-to anchoring. A robust stainless steel bracket allows for universal mounting on most sterns and transoms. Quick deployment of the anchor and line is easy with a new generation of Lewmar's Pro-Fish automatic free-fall mechanism. The proprietary 'auto-stop' system comes as standard in all models and helps prevent damage to the windlass, anchor and stern when stowing, allowing for hands free anchoring for the skipper.

- Specifically for stern anchoring
- Automatic Free-Fall & Auto-Stop as standard
- Robust universal bracket for secure and easy installation
- Single Gypsy allowing for 12-16mm diameter leaded line
- 6 models to suit boats up to 48ft
- Port & starboard mounting options available.



S900

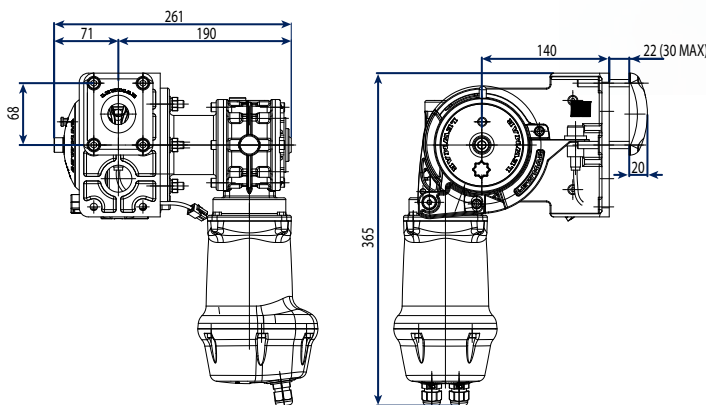

S2000

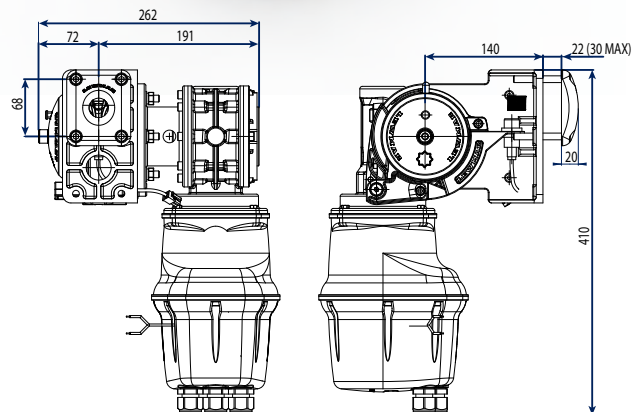

PART NUMBER		MODEL	MOTOR POWER	MAXIMUM PULL		WORKING LOAD LIMIT		MAXIMUM LINE SPEED		NORMAL CURRENT DRAW	CIRCUIT BREAKER	WEIGHT		GYPSY SPECIFICATIONS
PORT	STBD			WATT	KG	LB	KG	LB	M/MIN			FT/MIN	AMP	
69000940	69000941	S900 - 600W / 12V	600	409	900	200	440	17	56	85	90	11.6	26	12-16 MM (1/2 - 5/8") LEAD-CORE LINE
69000942	69000943	S2000 - 1000W / 12V	1000	910	2000	420	924	18	59	100	110	19.9	44	12-16 MM (1/2 - 5/8") LEAD-CORE LINE
69000944	69000945	S2000 - 1000W / 24V	1000	910	2000	420	924	18	59	50	60	19.9	44	12-16 MM (1/2 - 5/8") LEAD-CORE LINE

# I. Windlasses



## Tender Garage Winch

Lewmar have developed a new unit specifically to operate within a tender garage as an aid to stowing and deploying the tender:

The TW650 consists of an aluminium mounting frame and drum, hard anodised for durability and optimum protection against the harsh marine environment. The ABS motor cover is waterproof to IP68 standard.

The TW650 is C.E. Certified, conforming to EN28846:1993/A1:2000

Ignition Protection is included as standard for simple wiring installation in the stern garage.

- Complies with EN 28846:1993/A1:2000
- Drum can accommodate 9m of 8mm line (2 layers of wrap on drum)
- Working load = 250kg at 11m/min line speed, drawing 45 amps
- Max working load = 750kg at 8m/min line speed, drawing 150 amps
- Complete with line/float/hook

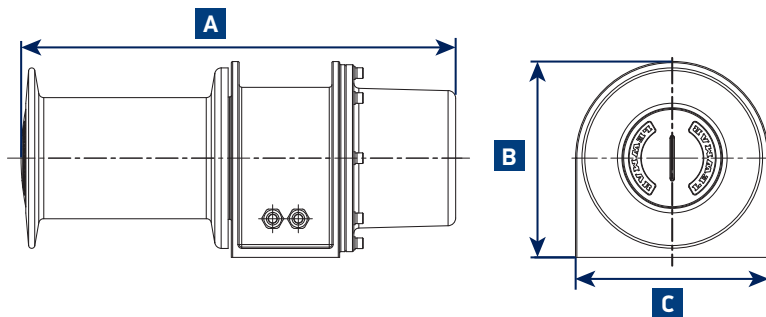

### Tender Garage Winch Specifications

PART NO	MOTOR POWER WATT	MOTOR SUPPLY VOLTAGE	MAX LINE SPEED		NORMAL CURRENT DRAW AMP	ROPE TYPE ROPE ONLY MAX DIMS	A	B	C
			M/MIN	FT/MIN			LENGTH MM	HEIGHT MM	WIDTH MM
66g10553	1000	24V	11	36	45	9M OF 8MM	337	152	150
69000807	1000	12V	11	36	45	9M OF 8MM	337	152	150

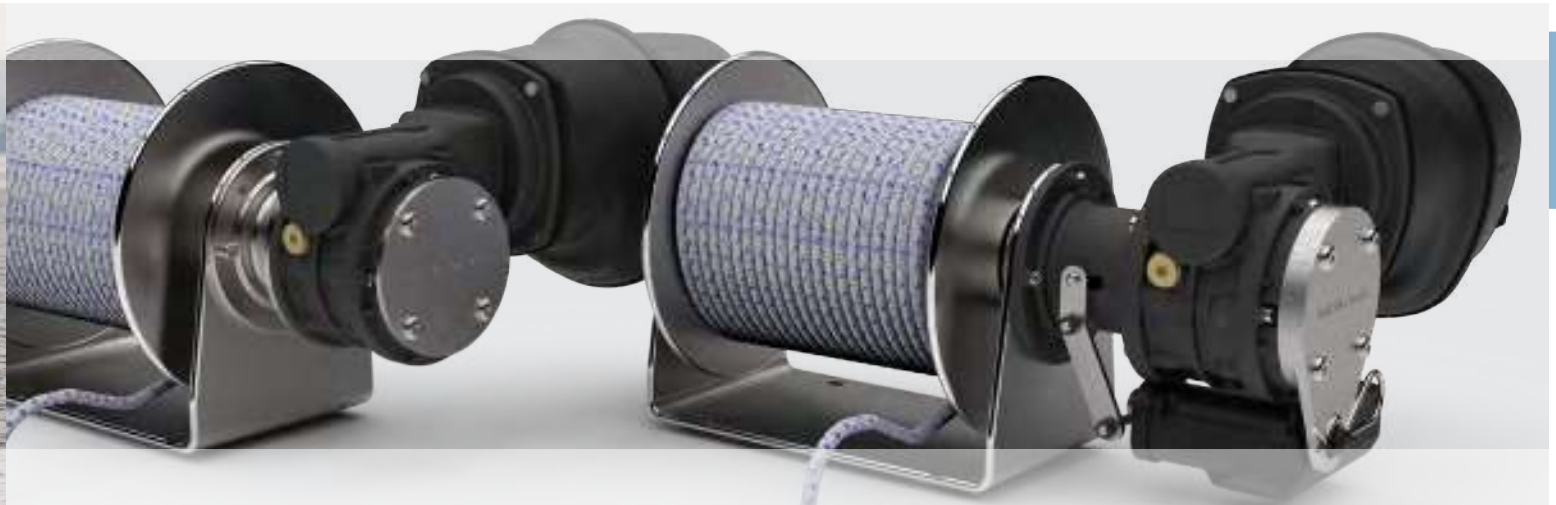

## Drum Windlass

The Drum windlass is the newest addition to the Lewmar windlass range. Calling on our experience in windlass and winch line management we have designed the drum windlass for stern or bow anchoring for boats up to 8m(26ft).

Combining a full stainless body and our proven 1000w IP68 rated motors as standard has provided a new windlass range that is built for durability, performance and optimum protection against the harsh marine environment.

### Small Drum

- Drum can accommodate 60m of 6mm line
- Plus 10m of chain 6mm chain
- Max line speed 41m/min
- Max working load = 1000kg

### Large Drum

- Drum can accommodate 75m of 8mm line
- Plus 10m of chain 8mm chain
- Max line speed 41m/min
- Max working load = 1000kg

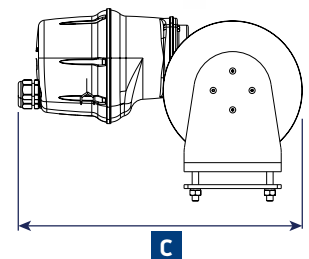
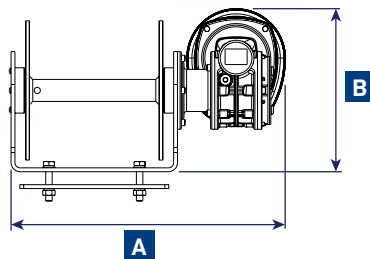

### Drum Windlass Specifications

PART NO	FREE FALL	MOTOR POWER WATT	MOTOR SUPPLY VOLTAGE	MAX LINE SPEED		ROPE TYPE ROPE ONLY MAX DIMS	A	B	C
				M/MIN	FT/MIN		LENGTH MM	HEIGHT MM	WIDTH MM
690001015		1000		41	134	6MM 3-STRAND	423	252	439
690001017	•	1000		41	134	6MM 3-STRAND	423	252	439
690001016		1000		41	134	8MM 3-STRAND	483	280	461
690001018	•	1000		41	134	8MM 3-STRAND	483	280	461

# I. Windlasses

## Switch kit and accessories



### 4 Circuit Breakers

PART NO.	DESCRIPTION	USE WITH WINDLASS MODEL
68000603	CIRCUIT BREAKER 25A	PRO-SPORT
68000604	CIRCUIT BREAKER 35A	V700
68000348	CIRCUIT BREAKER 50A	PRO-SPORT/ PRO-FISH 700W - CPX2/V2 24V - C3 24V, VX1 300, VX2/RX2 24V, HX1 500
68000240	CIRCUIT BREAKER 70A	PRO-SPORT/ PRO-FISH 1000W - CPX0 500W - C3 12V, VX1 500, HX1 800
68000349	CIRCUIT BREAKER 90A	CPX0 700W/ CPX1/ V1 - CPX2/ V2 12V - CPX3/ V3 24V - H2 12V - H3 24V, VX2/RX2 12V, VX2+/RX2+ 24V, VX3/RX3 24V
68000350	CIRCUIT BREAKER 110A	CPX3/ V3 12V - CPX4/ V4/ V5 24V - H3 12V - C4/ C5 24V, VX2+/RX2+ 12V, VX3/RX3 12V
68000351	CIRCUIT BREAKER 150A	CPX4/ V4 12V - V5 12V - V6 24V - C4/ C5 12V
68000894	CIRCUIT BREAKER 200A	V8 2.5KW
68000895	CIRCUIT BREAKER 250A	V8 3.5KW



### 5 Contactors



PART NO.	DESCRIPTION	VX1	VX/RX2/3	VX1-L	CPX0	CPX1	CPX2/3	CPX4	V700	V1	V2/3	V4	V5	V6	V8 2.5KW	V8 3.5KW	HX1	PRO-SERIES FISH 700	PRO-SERIES FISH 1000	PRO-SPORT	C3 TO C6	CRW400	S900	S2000
<b>SEALED CONTACTORS</b>																								
68000933	SINGLE 12V																							
68000934	SINGLE 24V																							
68000937	COMPACT DUAL 12V		•		•	•	•			•	•													
68000938	COMPACT DUAL 24V		•																					
68000318	DUAL 12V					•	•			•	•													
68000319	DUAL 24V						•						•											
68000939	COMPACT DUAL 12V	•		•													•	•	•	•			•	
68000320	DUAL 12V							•	•			•												
68000321	DUAL 24V							•				•												
<b>CONTACTORS IN BOXES</b>																								
18000301	SINGLE 12V																							
18000302	SINGLE 24V																							
68000129	DUAL 12V		•							•	•													
68000130	DUAL 24V		•																					
18000200	DUAL 12V	•		•								•						•	•					
18000237	DUAL 24V											•												
<b>PRE-WIRED CONTACTORS IN BOXES WITH FUSE</b>																								
68000919	SINGLE 12V																							•
68000920	SINGLE 24V																							•

## 6 Switches

### CHSX Foot Switch

- Suitable for DC electric windlasses running on 12 or 24V
- IP67/5 rated for water resistance
- Twin sealed switch compartment
- Composite plastic body
- Available with polished stainless steel or composite plastic lid
- New lower-profile design with updated styling

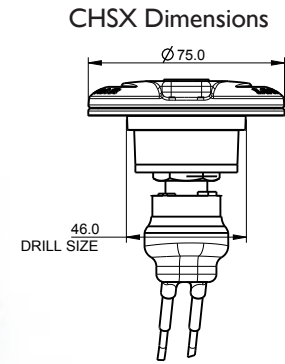

DESCRIPTION	BLACK PART NUMBER	STAINLESS STEEL PART NUMBER
CLOSED LID	68001249	68001257
OPEN LID	68001256	68001258

### Deck Foot Switch

- Suitable for DC electric windlasses running on 12 or 24V
- Single direction switch
- Hinged cover to prevent accidental operation
- Available in grey, white, or stainless steel
- Normally open contact, 5A (12 & 24V)
- Ready to install
- Must be used with a contactor or control box



68000883  
Grey Foot Switch



68000930  
White Foot Switch



68000888  
Stainless Steel Foot Switch

DESCRIPTION	GREY PART NUMBER	WHITE PART NUMBER	STAINLESS STEEL PART NUMBER
WINDLASS DOWN	68000883	68000918	68000888
WINDLASS UP	68000884	68000917	68000889
BLANK	68000928	68000930	68000929

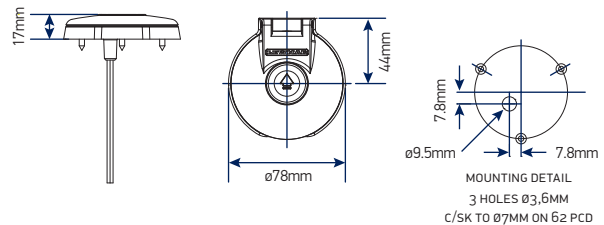

### Custom Deck Switches

Lewmar has developed a range of stylish Custom Deck Switches. The new Custom Deck Switch can be used for any winch or windlass application.

- Sealed switch with strong rubber button cover
- Stainless steel main body
- Polished or blasted finishes as standard (custom finishes available)
- Easy replacement of bellows
- Must be used with a contactor or control box



DESCRIPTION	MIRROR POL (MIRROR FINISH)	BLASTED (MATTE FINISH)
CLOSED	48000257	48000259
OPEN	48000256	48000258

# I. Windlasses



## 6 Remotes

### Wireless RF Remote Control

- 3-Button Windlass Wireless Remote Control allows wireless remote up/down operation of any Lewmar windlass
- Wireless range of up to 20m (without obstruction)
- 5-Button Windlass & Thruster Remote Control allows wireless port/starboard thrust operations of any Lewmar Thruster, and wireless up/down operation of any Lewmar Windlass
- Easily retrofitted to existing installations
- Kit includes one wireless fob and one receiver that supports up to eight remote key fobs. Additional fobs sold separately.
- Include a replaceable battery
- The fobs float and are waterproof to IP67 (1 metre deep)
- Using over 1 billion individual codes, a proprietary encryption scheme prevents false triggering from any other device or similar fob
- FCC & CE Compliant

### 3-Button Windlass Wireless Remote Kit

PART NUMBER	DESCRIPTION
68000967	3-BUTTON WINDLASS WIRELESS REMOTE KIT

### 5-Button Windlass & Thruster Wireless Remote Kit

PART NUMBER	DESCRIPTION
68000968	5-BUTTON WINDLASS & THRUSTER WIRELESS REMOTE KIT



Kit includes a receiver and a 3 button wireless fob



Kit includes a receiver and a 5 button wireless fob



### Additional Fobs

PART NUMBER	DESCRIPTION
68001005	3-BUTTON SPARE FOB
68001006	5-BUTTON SPARE FOB



### 10m Remote Antenna Kit

PART NUMBER	DESCRIPTION
68000969	10M REMOTE ANTENNA KIT



When reception is poor or distance to the windlass/thruster is long, a remote antenna will improve reception.

### Guarded Rocker Switch

PART NUMBER	DESCRIPTION
68000593	DUAL DIRECTION SWITCH



### Hand held cable remote control

PART NUMBER	DESCRIPTION
69000819	AA320 HAND HELD WIRED REMOTE CONTROL

- Ergonomic shape with rubber over-moulding for shock protection and grip
- Can operate in parallel with other control equipment
- Connect to DC, AC and Hydraulic systems
- Rugged cable connectors with moulded plug and socket rated to IP67



# I. Windlasses



## Wired Windlass Remote

The 2 button wired windlass remote is the latest design of IP rated hand-held remote from Lewmar. The new unit is designed for remote operation of all Lewmar windlasses. The wired remote is constructed with high-strength, glass-reinforced PP combined with a high-density rubber gasket to ensure robust durability and a secure grip whatever the conditions. These units are supplied complete with a connecting cable extendable up to 3 meters, a watertight deck fitting and socket, and a support bracket for stowing.

- IP67 plug & socket included
- Wall plate included
- 3m of cable (pre-fitted with plug)
- Waterproof to IP67 (EN 60529) handset
- Over-moulded soft touch rubber buttons
- Can be used on both 12V and 24V systems
- Flange mount socket and sealing cap included

PART NUMBER	DESCRIPTION
66940002	WIRED WINDLASS REMOTE KIT







## Chain Counters

A chain-counter allows the scope of chain/rope to be more accurately measured, ensuring quicker, safer anchoring under any conditions. Lewmar distribute the full range of AutoAnchor chain counters, varying from a basic panel-mounted chain counter to a full multi-station capable wireless control. The AutoAnchor product makes a great add-on to any of Lewmar's vertical windlasses. New plug and play cables reduces installation time.

AA150 – Chain counter

**Part No: 66830014**

Displays the length of rode deployed through the windlass.

- LCD display shows at a glance how much anchor rode is out
- Docking alarm sounds when the anchor is close to docking
- Now plug and play AA sensor installation
- Works with rope/chain or all-chain rode
- Use with DC, AC and hydraulic windlasses
- Install up to 2 units or combine with the AA560, AA710 or AA300 series for multiple stations on the boat
- Standard 60mm (2.36") marine instrument console

### Kit Includes:

- Console with sensor plug and fastening kit
- 1 magnet (10mm x 8mm)
- Grey sensor with 2m sensor cable and plug (Use for all-chain or rope/chain installations)
- Motor load sensor terminators (Use for rope/chain installations)
- Installation instructions and user manual



### Dimensions

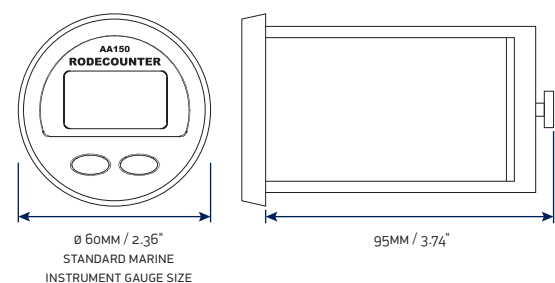

### Specifications

POWER SUPPLY	CURRENT CONSUMPTION	TEMPERATURE RANGE	MAXIMUM VOLTAGE	EMC PROTECTION/CE
12 OR 24V DC	30MA	-5 TO 60°C (23 TO 140°F)	30V DC	EN609945

# I. Windlasses

## AutoAnchor SmartBox – AA802 - NMEA Compatible

The world's most advanced chain counter has arrived. The core of the AutoAnchor range means fewer complications and greater control over your anchoring. SmartBox technology opens up myriad of anchor monitoring possibilities when combined with 3rd party information such as GPS and depth. AutoAnchor can now transform other anchor watch software into a more comprehensive anchoring tool.

- Very accurate chain and rope count
- Simplified installation, set up and calibration.
- Daisy-chain wiring to read outs with a single cable or via Bluetooth
- NMEA2000 for 3rd party displays and for integrated information
- Bluetooth Wireless for excellent wireless coverage and links to smartphone apps or plotters
- Improved sensor technology



## SmartSensor – AA001

- 3-Axis Reading gives Auto Directional Detection; no need for up/down input signal
- Rope/chain auto detection
- No need for load wires
- High sensitivity for improved sensing distance

## SmartConsole - AA870 / Smart Remote – AA810

- Interface wirelessly with 3rd-party hardware, including direct to your phone via the AutoAnchor app
- Reliable wireless or NMEA2000 connectivity
- Effortless addition of multiple counters

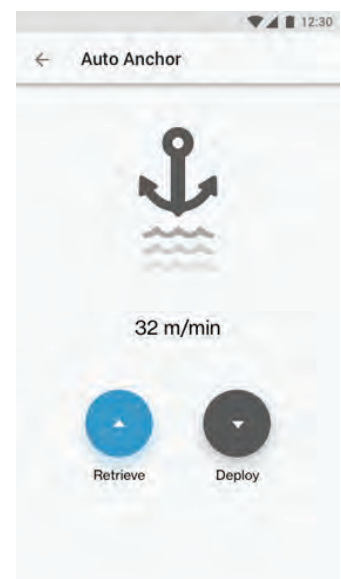

## Chain counter AA560 / AA570

Controls the windlass from the helm station and shows at a glance how much anchor rode is deployed.

- "One touch" automatic function deploys and retrieves a preset length of anchor rode making anchoring easier and safer
- Docking alarm and preset stopping point help protect the boat during anchor retrieval
- Use with DC, AC and hydraulic windlasses
- Install up to 2 units or combine with the AA150, AA710 or AA300 series for multiple stations on the boat
- The new AA570 wireless panel-mount rode counter is a wireless version of the AA560

### Dimensions

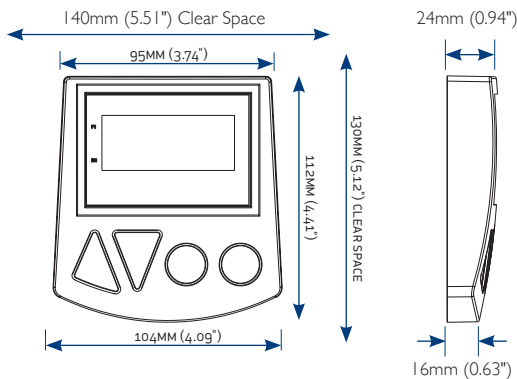

### Specifications

POWER SUPPLY	CURRENT CONSUMPTION	TEMPERATURE RANGE	MAX. VOLTAGE	EMC PROTECTION/CE
12 OR 24V DC	70MA	-5 TO 60°C (23 TO 140°F)	30V DC	EN609945

### AA560 Part No 66830015

#### Kit Includes:

- Console with sensor plug and fastening kit
- Grey sensor with 2m sensor cable and plug (Use for all-chain or rope/chain installations)
- 1 magnet (10mm x 8mm)
- Motor load sensor terminators (Use for rope/chain installations)
- Installation instructions and user manual

### AA570 Part No 66830041

#### Kit Includes:

- Console with sensor plug and fastening kit
- Base Station (AA702A) with male sensor plug
- Grey sensor with 2m sensor cable and plug (Use for all-chain or rope/chain installations)
- 1 magnet (10mm x 8mm)
- Motor load sensor terminators (Use for rope/chain installations)
- Installation instructions and user manual

## AA730 – Wired Remote control with LCD and chain counter

### Part No: 66830040

Waterproof control for windlass or thruster with chain counter

- Full windlass control and chain counting
- Controls bow and/or stern thrusters
- 4 metres spiral cable
- Stowage on cradle
- Use with DC, AC and Hydraulic systems
- Operates in parallel with other control equipment eg toggle switches, foot switches and other electronic controllers.

#### Kit Includes:

One handheld console unit with cradle, one base station, a deck socket with 2m lead, a socket sealing cap, one sensor, 2 magnets, screws for the cradle and socket, installation and operation instructions.



# I. Windlasses

## AA710 – Wireless windlass control and chain counter

Part No: 66830011

Handheld device to control the windlass and other devices with integrated chain counter feature.

- Full windlass control and chain counting
- Controls bow and/or stern thrusters
- Preset the length of rode to deploy
- Auto stop and docking alarm when the anchor is close to docking
- High level wireless transmission security includes unique ID and registration for every unit
- Safety lock reduces unwanted operation
- Displays signal strength and battery level
- Use with DC, AC and Hydraulic systems
- Operates in parallel with other control equipment eg toggle switches, foot switches and other electronic controllers.



### Kit Includes:

- Hand Held Radio Remote Control Unit (AA710)
- Base Station (AA702A) with male sensor plug
- Grey sensor with 2m sensor cable and plug (Use for all-chain or rope/chain installations)
- 1 Magnet (10mm x 8mm)
- Motor load sensor terminators (Use for rope/chain installations)
- Installation instructions and user manual

## AA601 – Rode counter for glass bridge PC or PLC display

Part No: 66830035

The AA601 connects to the onboard computer for monitoring the length of rode deployed through the windlass.

- Rode length monitoring from the onboard computer.
- Connection via RS485 serial port or USB direct.
- Pre-programmed calibrations for rope/chain rodes
- An alarm warns skipper when anchor is close to docking
- Use with DC, AC and Hydraulic systems



### Spare cables and accessories

- For easy installation the cables have male connectors at both ends (M-M).
- The sensors and console have female connectors.
- Chain counters use 3 wire shielded cables to meet the EN 60945 EMC requirements.

PART NUMBER	DESCRIPTION	PLUG & PLAY SENSOR EXTENSION CABLES	
		PART NUMBER	DESCRIPTION
66830025	2M DUAL INSTRUMENT CABLE	66830021	6.5M CABLE
66830026	DUAL INSTRUMENT T-JUNCTION CONNECTOR	66830027	10M CABLE
66830030	SENSOR MALE FIELD CONNECTOR	66830022	15M CABLE
66830031	SENSOR FEMALE FIELD CONNECTOR	66830023	20M CABLE
66830032	SENSOR CABLE GENDER CHANGE	66830028	25M CABLE
66830016	ANTENNA EXTENSION 10M	66830029	35M CABLE
66000639	SENSOR AND MAGNET KIT		

# Windlass Spares

## VX1 Parts list

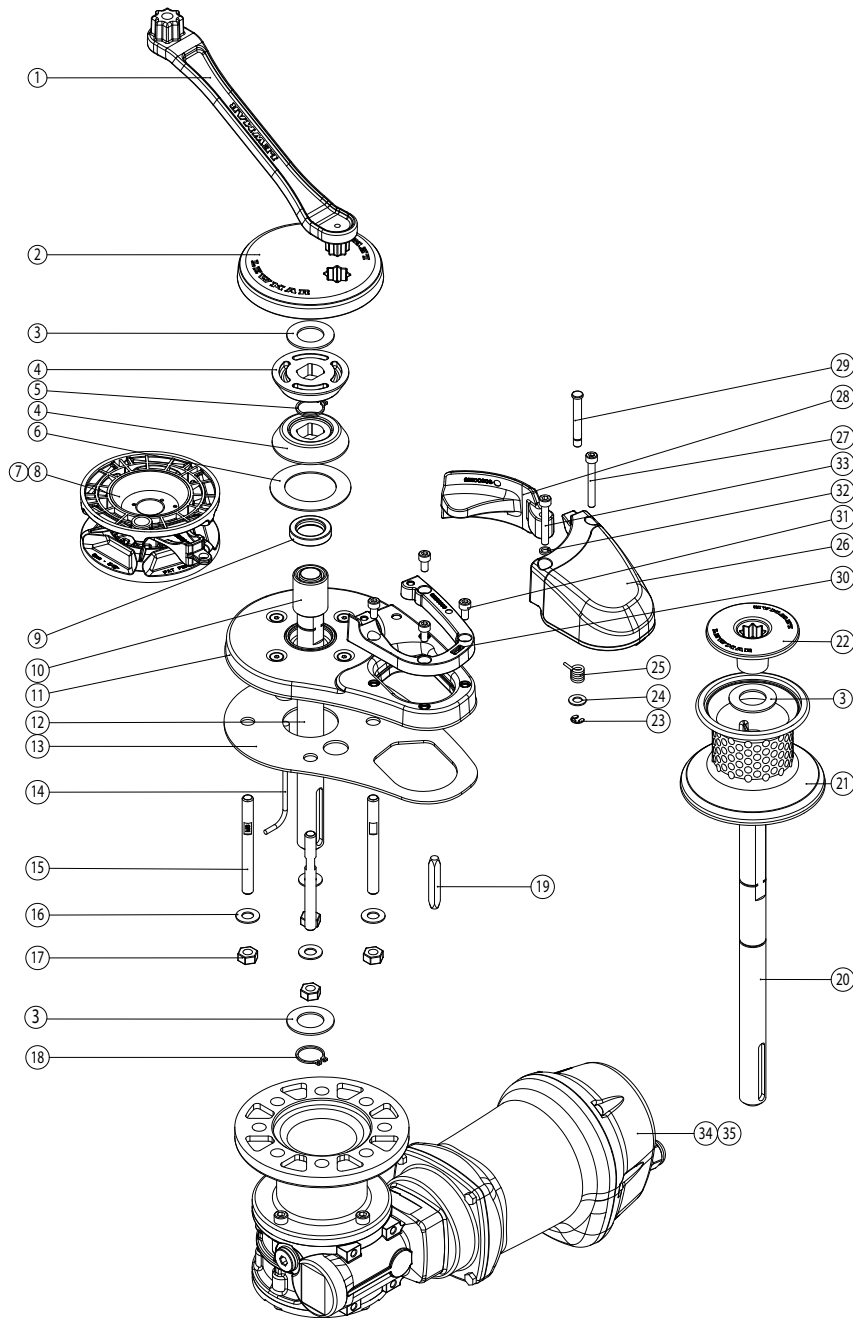

KIT NO.	KIT DESCRIPTION	ITEMS INCLUDED (QTY.)
66000799	WINDLASS HANDLE	1(1)
66100120	VX1 GYPSY ONLY TOP CAP KIT	2(1)
66100121	VX1 BASE KIT	9(1), 10(1), 11(1), 30(1), 31(4)
66100123	VX1 CHAIN COVER AND CONTROL ARM KIT	23(1), 24(1), 25(1), 26(1), 27(1), 28(1), 29(1), 32(1), 33(1)
66100124	VX1 DRUM KIT	3(1), 21(1), 22(1),
66100125	VX1 GYPSY ONLY DRIVE KIT	2(1), 3(1), 5(1), 12(1), 18(1), 19(1)
66100126	VX1 GYPSY DRUM DRIVE KIT	2(1), 3(2), 5(1), 18(1), 19(1), 20(1), 21(1), 22(1)
66100127	VX1 MANUAL AND KIT	1(1), 13(1), 15(4), 16(4), 17(4)
68100033	VX1 8MM GYPSY Ⓞ STRIPPER ASSEMBLY	3(1), 4(2), 6(1), 7(1)
68100034	VX1 6/7MM 1/4" GYPSY Ⓞ STRIPPER ASSEMBLY	3(1), 4(2), 6(1), 8(1)
68100035	VX1 12V 300W IP67 RMU40 M/GBOX	34(1)
68100036	VX1 12V 500W IP67 RMU40 M/GBOX	35(1)

# I. Windlasses

## VX1L Parts list

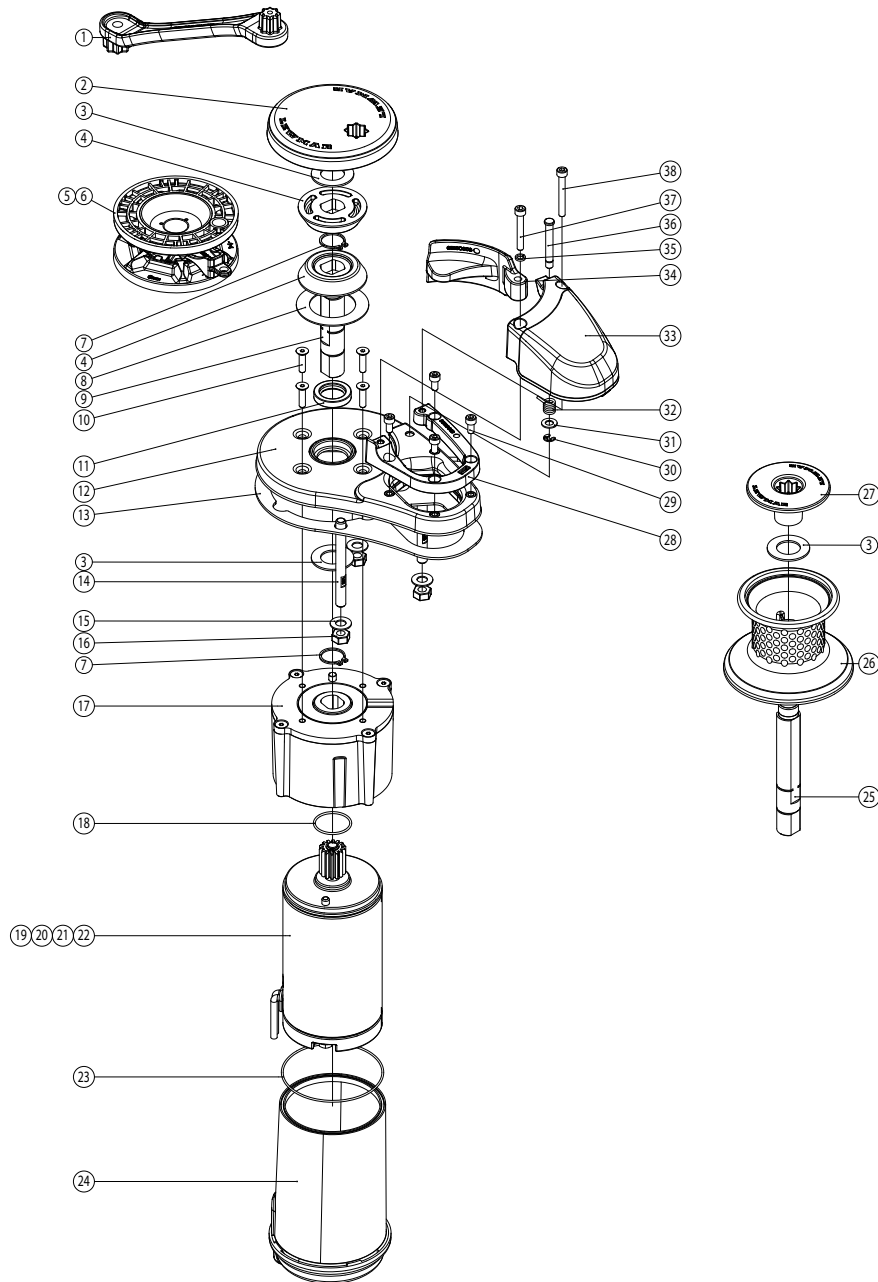

KIT NO.	KIT DESCRIPTION	ITEMS INCLUDED (QTY.)
66000799	WINDLASS HANDLE	1(1)
66100120	VX1 GO TOP CAP KIT	2(1)
66100122	VX1L BASE UNIT	10(4), 11(1), 12(1), 28(1), 29(4)
66100123	VX1 CHAIN COVER & C/ARM KIT	30(1), 31(1), 32(1), 33(1), 34(1), 35(1), 36(1), 37(1), 38(1)
66100124	VX1 DRUM KIT	3(1), 26(1), 27(1)
66100128	VX1L MANUAL AND KIT	1(1), 13(1), 14(3), 15(3), 16(3)
66100129	VX1L GO DRIVE KIT	2(1), 3(1), 7(2), 9(1)
66100130	VX1L GD DRIVE KIT	3(2), 7(2), 25(1), 26(1), 27(1)
66100135	VX1L 12V 500 M/G-BOX ASSY	17(1), 18(1), 19(1), 23(1), 24(1)
66100136	VX1L 24V 500 M/G-BOX ASSY	17(1), 18(1), 20(1), 23(1), 24(1)
66100137	VX1L 12V 800 M/G-BOX ASSY	17(1), 18(1), 21(1), 23(1), 24(1)
66100138	VX1L 24V 800 M/G-BOX ASSY	17(1), 18(1), 22(1), 23(1), 24(1)
66100139	VX1L/HX1 12V 500 MOTOR ASSY	19(1)
66100140	VX1L/HX1 24V 500 MOTOR ASSY	20(1)
66100141	VX1L/HX1 12V 800 MOTOR ASSY	21(1)
66100142	VX1L/HX1 24V 800 MOTOR ASSY	22(1)
68100033	VX1 8MM GYPSY ST/ST STRIPPER ASSY	3(1), 4(2), 5(1), 8(1)
68100034	VX1 6/7MM 1/4" GYPSY ASSY ST/ST	3(1), 4(2), 6(1), 8(1)

VX2/3 Parts List

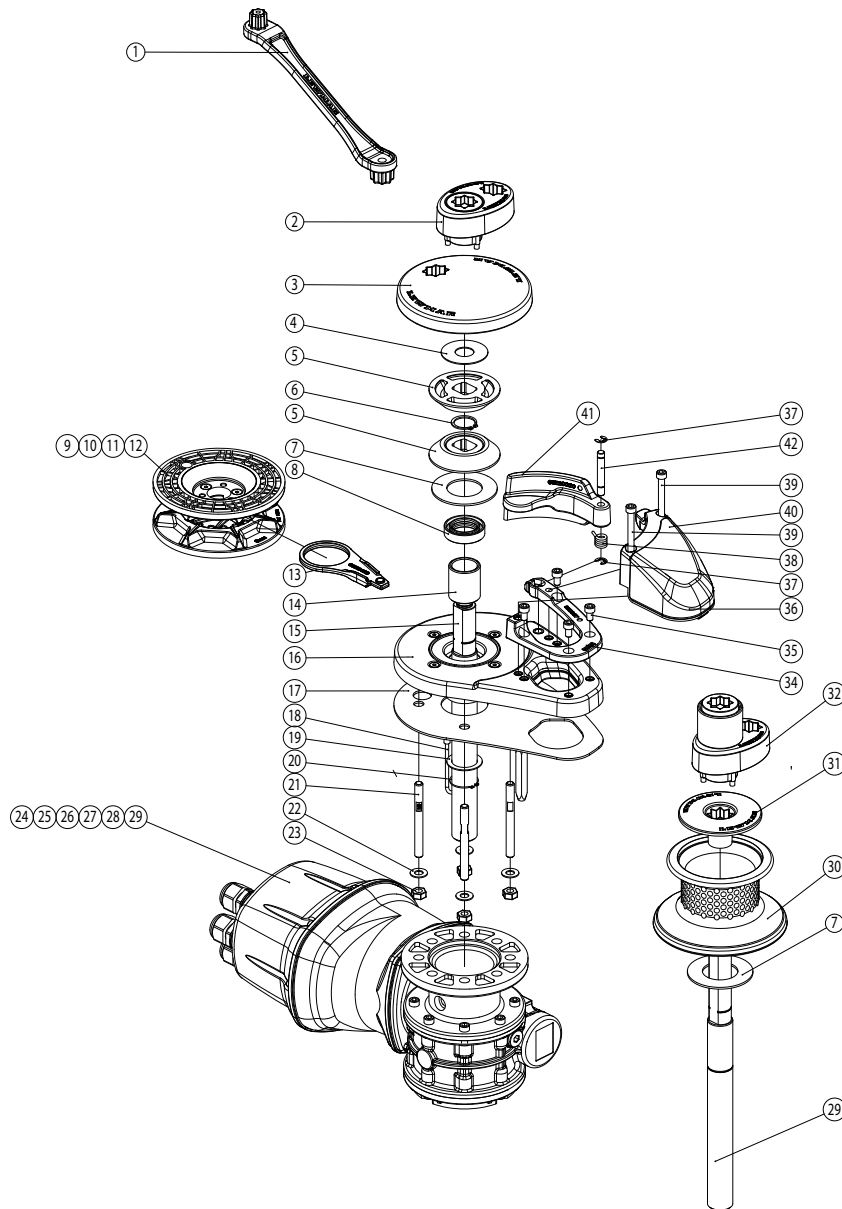

KIT NO.	KIT DESCRIPTION	ITEMS INCLUDED (QTY.)
66000799	WINDLASS HANDLE	1(1)
66120001	VX2/3 GO TOP CAP REPLACEMENT	3(1)
66120002	VX2/3 BASE KIT	8(1), 14(1), 16(1), 18(1), 34(1), 35(4), 37(1), 42(1)
66120003	VX2/3 CHAIN COVER KIT	39(2), 40(1)
66120004	VX2/3 CONTROL ARM KIT	37(2), 38(1), 41(1), 42(1)
66120005	VX2/3 DRUM KIT	7(1), 30(1), 31(1)
66120006	VX2/3 GYPSY ONLY DRIVE KIT	3(1), 6(1), 15(1), 19(1), 20(1)
66120007	VX2/3 DRUM DRIVE KIT	6(1), 19(1), 20(1), 29(1)
66120008	VX2/3 MANUAL Ⓢ KIT	1(1), 17(1), 21(4), 22(4), 23(4)
66120009	VX2/3 GO MANUAL RECOVERY RETAIL KIT	2(1)
66120010	VX2/3 GD MANUAL RECOVERY RETAIL KIT	32(1)
66120011	VX2/3 STRIPPER RING REPLACEMENT	13(1)
68120031	VX2 MOTOR G/BOX 700W 12V SZ50 IP ASSY	24(1)
68120032	VX2 MOTOR G/BOX 900W 24V SZ50 IP ASSY	25(1)
68120033	VX2+ MOTOR G/BOX 1000W 24V SZ50 IP ASSY	26(1)
68120034	VX2+ MOTOR G/BOX 1000W 12V SZ50 IP ASSY	27(1)
68120035	VX3 1500W 12V M/G-BOX	28(1)
68120036	VX3 MOTOR G/BOX 1500W 24V SZ50 IP ASSY	28(1)
68120040	GYPSY ASSY 6/7MM VX2/3 ST/ST	4(1), 5(2), 7(1), 9(1), 13(1)
68120041	GYPSY ASSY 8MM VX2/3 ST/ST	4(1), 5(2), 7(1), 9(1), 14(1)
68120042	GYPSY ASSY 10MM DIN VX2/3 ST/ST	4(1), 5(2), 7(1), 9(1), 15(1)
68120043	GYPSY ASSY 10MM ISO VX2/3 ST/ST	4(1), 5(2), 7(1), 9(1), 16(1)

# I. Windlasses

## RX Parts list

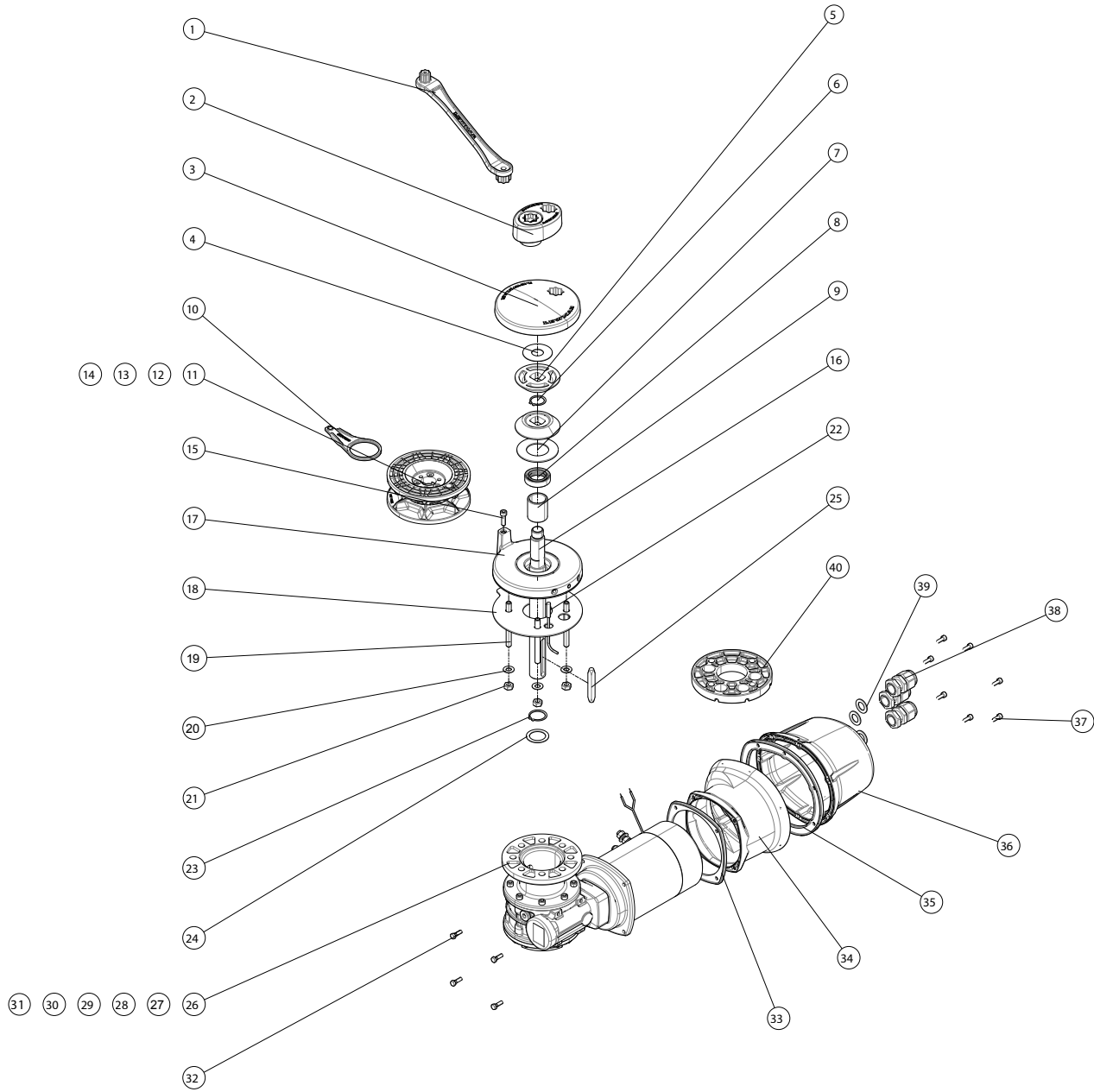

KIT NO.	KIT DESCRIPTION	ITEMS INCLUDED (QTY.)
66000799	WINDLASS HANDLE	1(1)
66100143	VX THIN DECK SPACER	40(1)
66120001	VX2/3 GO TOP CAP REPLACEMENT	3(1)
66120006	VX2/3 GYPSY ONLY DRIVE KIT	3(1), 6(1), 16(1), 23(1), 24(1), 25(1)
66120009	VX2/3 GO MANUAL RECOVERY RETILA KIT	2(1)
66120011	VX2/3 STRIPPER RING REPLACEMENT	10(1)
66120012	RMU50 IP COVER KIT	32(4), 33(1), 34(1), 35(1), 36(1), 37(7), 38(3), 39(3)
66120013	RX DECK UNIT KIT	8(1), 9(1), 15(1), 17(1), 22(1)
66120014	RX MANUAL AND KIT	1(1), 18(1), 19(4), 20(4), 21(4)
68120031	VX2 MOTOR G/BOX 700W 12V SZ50 IP ASSY	26(1), 32(4), 33(1), 34(1), 35(1), 36(1), 37(7), 38(3), 39(3)
68120032	VX2 MOTOR G/BOX 900W 24V SZ50 IP ASSY	27(1), 32(4), 33(1), 34(1), 35(1), 36(1), 37(7), 38(3), 39(3)
68120033	VX2+ MOTOR G/BOX 1000W 24V SZ50 IP ASSY	28(1), 32(4), 33(1), 34(1), 35(1), 36(1), 37(7), 38(3), 39(3)
68120034	VX2+ MOTOR G/BOX 1000W 12V SZ50 IP ASSY	29(1), 32(4), 33(1), 34(1), 35(1), 36(1), 37(7), 38(3), 39(3)
68120035	VX3 MOTOR G/BOX 1500W 12V SZ50 IP ASSY	30(1), 32(4), 33(1), 34(1), 35(1), 36(1), 37(7), 38(3), 39(3)
68120036	VX3 MOTOR G/BOX 1500W 24V SZ50 IP ASSY	31(1), 32(4), 33(1), 34(1), 35(1), 36(1), 37(7), 38(3), 39(3)
68120040	GYPSY ASSY 6/7MM VX2/3 ST/ST	4(1), 5(2), 7(1), 10(1), 11(1)
68120041	GYPSY ASSY 8MM VX2/3 ST/ST	4(1), 5(2), 7(1), 10(1), 12(1)
68120042	GYPSY ASSY 10MM DIN VX2/3 ST/ST	4(1), 5(2), 7(1), 10(1), 13(1)
68120043	GYPSY ASSY 10MM ISO VX2/3 ST/ST	4(1), 5(2), 7(1), 10(1), 14(1)



CPX0 Parts list

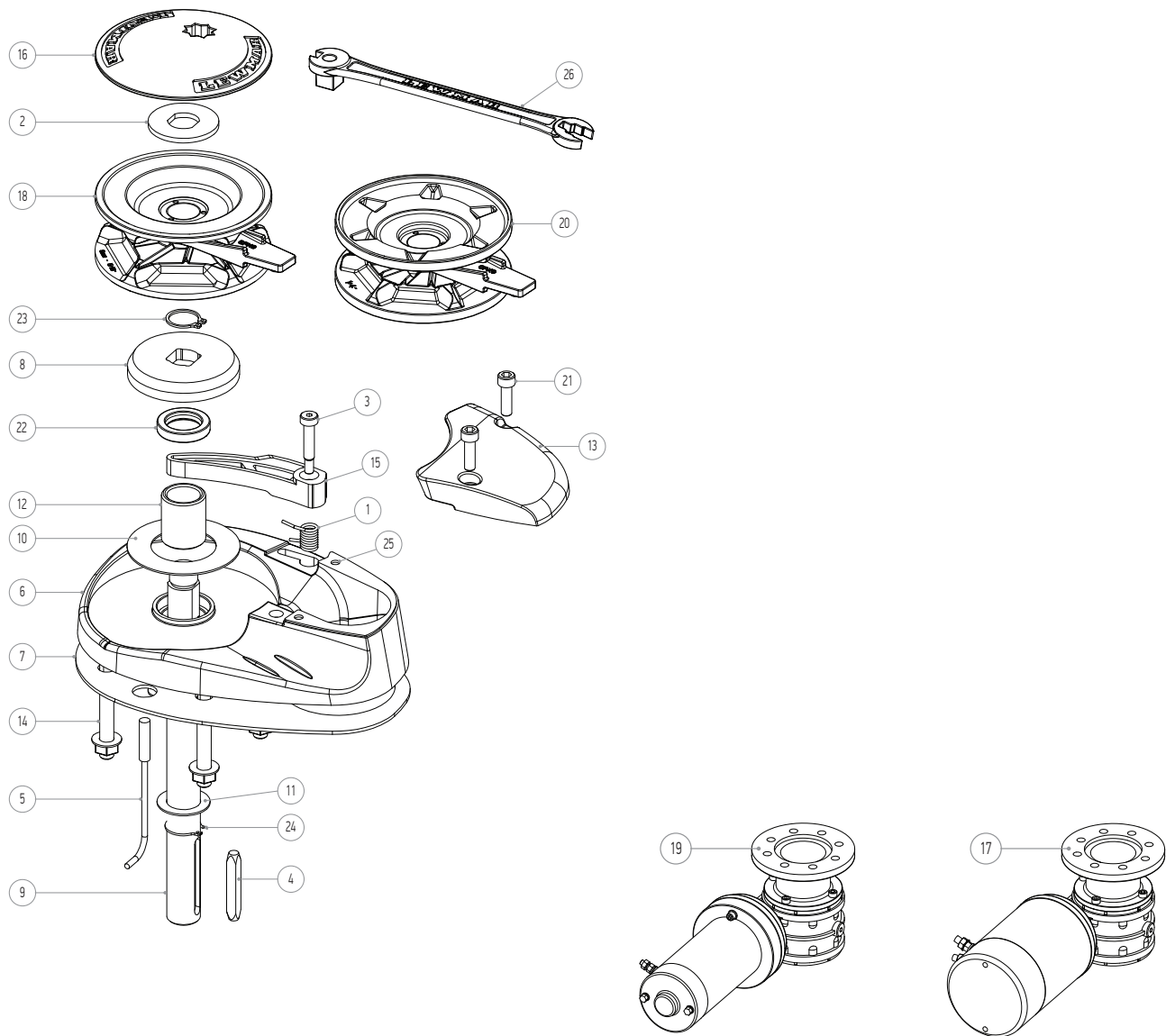

KIT NO	DESCRIPTION	ITEMS INCLUDED (QTY)
66000770	BASE KIT	6(1), 12(1), 22(1), 25(2)
66000771	CHAIN COVER KIT	13(1), 21(2)
66000601	GYPSY CAP KIT	2(1), 16(1)
66000772	CONE AND WASHER KIT	2(1), 8(1), 10(1)
66000600	CONTROL ARM KIT	1(1), 3(1), 15(1)
66000773	MOUNTING KIT	7(1), 14(1)
66000774	DRIVESHAFT KIT	4(1), 9(1), 11(1), 23(1), 24(1)
68001123	8MM - 5/16" GYPSY AND STRIPPER KIT	18(1)
68001126	6MM - 7MM - 1/4" GYPSY AND STRIPPER KIT	20(1)
68001125	12V, 500W MGB AND CONTACTOR	19(1)
68001035	12V, 700W MGB AND CONTACTOR	17(1)
66000805	CLUTCH LEVER	26(1)

# I. Windlasses

CPXI Parts list

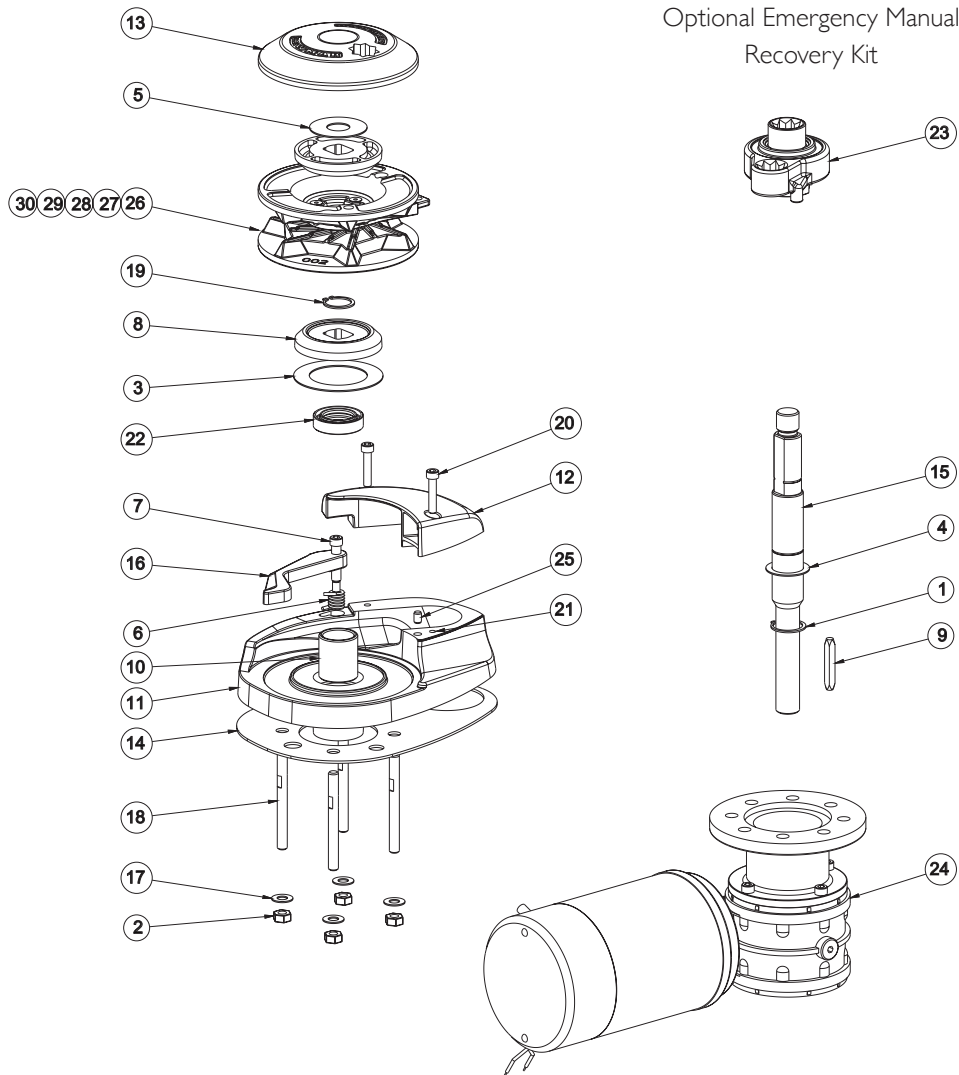

KIT NO.	KIT DESCRIPTION	ITEMS INCLUDED (QTY.)
66000791	BASE KIT	3(1), 6(1), 7(1), 10(1), 11(1), 12(1), 16(1), 20(2), 21(2), 22(1), 25(1)
66000792	CHAIN COVER KIT	12(1), 20(2)
66000741	GYPSY ONLY TOP NUT KIT	5(1), 13(1)
66000720	CONES & WASHER KIT	3(1), 5(1), 8(2)
66810030	CONTROL ARM KIT	6(1), 7(1), 16(1)
66000793	MOUNTING KIT	2(4), 14(1), 17(4), 18(4)
66000743	DRIVESHAFT KIT	1(1), 4(1), 9(1), 15(1), 19(1)
68001042	12V MOTOR GEARBOX & CONTACTOR	24(1)
66840084	GYPSY ONLY EMERGENCY KIT	23(1)
68001047	GYPSY & STRIPPER KIT (006)	26(1)
68001048	GYPSY & STRIPPER KIT (000)	27(1)
68001049	GYPSY & STRIPPER KIT (001)	28(1)
68001050	GYPSY & STRIPPER KIT (002)	29(1)
68001051	GYPSY & STRIPPER KIT (003)	30(1)

CPX2/3 Parts list

Optional GO Emergency Manual Recovery Kit

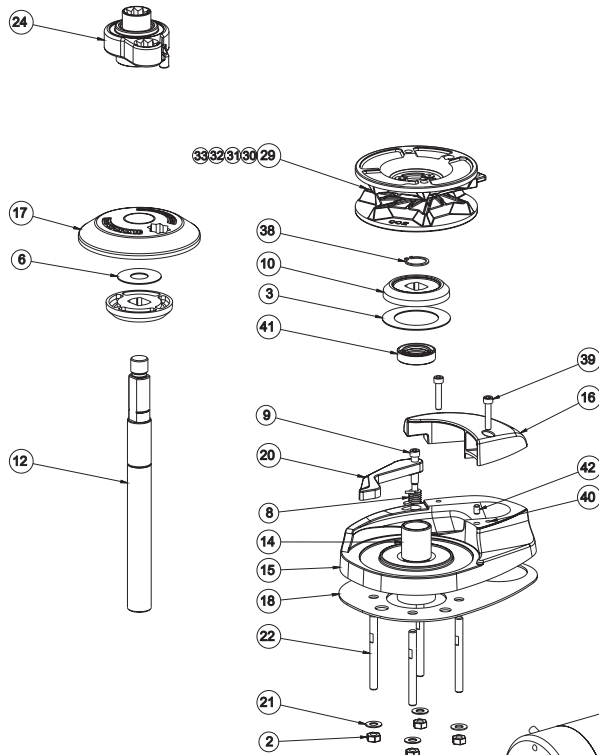

Optional GD Emergency Manual Recovery Kit

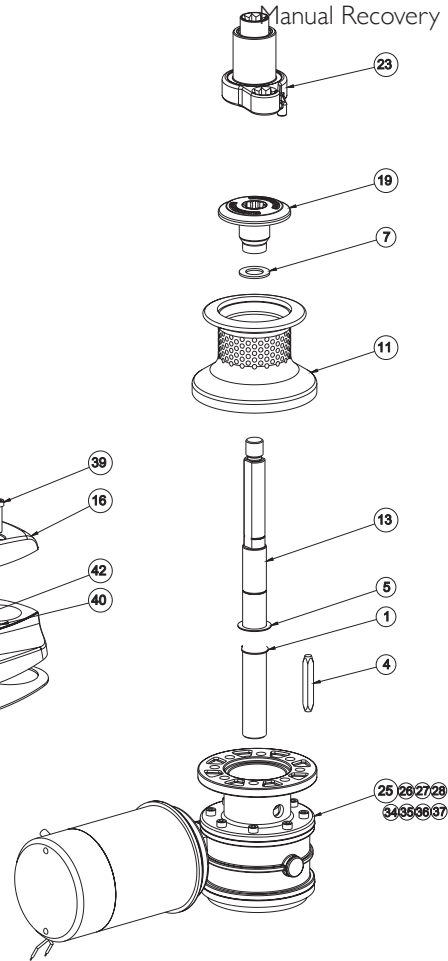

KIT NO.	KIT DESCRIPTION	ITEMS INCLUDED (QTY.)
66000791	BASE KIT	3(1), 8(1), 9(1), 14(1), 15(1), 16(1), 20(1), 39(2), 40(2), 41(1), 42(1)
66000792	CHAIN COVER KIT	16(1), 39(2)
66000741	GYPSY ONLY TOP NUT KIT	6(1), 17(1)
66000744	GYPSY/DRUM TOP NUT KIT	7(1), 19(1)
66000745	DRUM KIT	7(1), 11(1), 19(1)
66000720	CONES & WASHER	3(1), 6(1), 10(2)
66810030	CONTROL ARM KIT	8(1), 9(1), 20(1)
66000713	MOUNTING KIT	2(4), 18(1), 21(4), 22(4)
66000746	GYPSY ONLY DRIVESHAFT KIT	1(1), 4(1), 5(1), 12(1), 38(1)
66000747	GYPSY/DRUM DRIVESHAFT KIT	1(1), 4(1), 5(1), 13(1), 38(1)
66840056	GYPSY/DRUM EMERGENCY KIT	23(1)
66840084	GYPSY ONLY EMERGENCY KIT	24(1)
68001048	GYPSY & STRIPPER KIT (000)	30(1)
68001049	GYPSY & STRIPPER KIT (001)	31(1)
68001050	GYPSY & STRIPPER KIT (002)	32(1)
68001051	GYPSY & STRIPPER KIT (003)	33(1)
68001047	GYPSY & STRIPPER KIT (006)	29(1)
68001043	CPX2 12V MOTOR GEARBOX & CONTACTOR	25(1)
68001044	CPX2 24V MOTOR GEARBOX & CONTACTOR	26(1)
68001045	CPX3 12V MOTOR GEARBOX & CONTACTOR	27(1)
68001046	CPX3 24V MOTOR GEARBOX & CONTACTOR	28(1)
68001073	CPX2 12V IP68 MGB - NO CABLES	34(1)
68001074	CPX2 24V IP68 MGB - NO CABLES	35(1)
68001075	CPX3 12V IP68 MGB - NO CABLES	36(1)
68001076	CPX3 24V IP68 MGB - NO CABLES	37(1)

# I. Windlasses

## CPX4/5 Parts list

### Optional GO Emergency Manual Recovery Kit

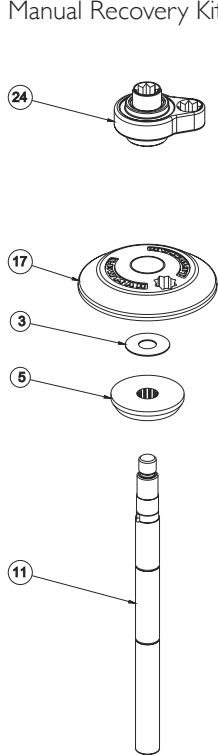

### Optional GO Emergency Manual Recovery Kit

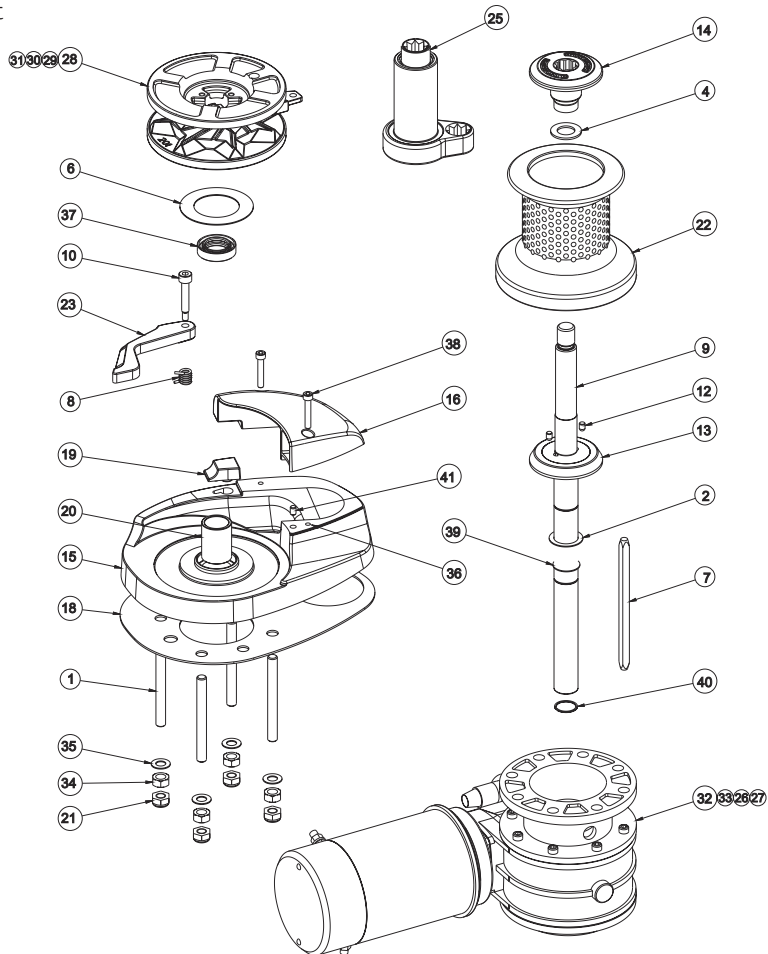

KIT NO.	KIT DESCRIPTION	ITEMS INCLUDED (QTY.)
66000794	BASE KIT	15(1), 16(1), 19(1), 20(1), 36(2), 37(1), 38(2), 41(1).
66000795	CHAIN COVER KIT	16(1), 38(2)
66000750	TOP NUT KIT GYPSY ONLY	3(1), 17(1)
66000744	TOP NUT KIT GUPSY DRUM	4(1), 14(1)
66000751	DRUM KIT	4(1), 14(1), 22(1)
66000752	CONES & WASHER	3(1), 5(1), 6(1), 12(2), 13(1)
66810031	CONTROL ARM KIT	8(1), 10(1), 23(1)
66000796	MOUNTING KIT	1(4), 18(1), 21(4), 34(4), 35(4)
66000754	DRIVESHAFT KIT GYPSY ONLY	2(1), 7(1), 11(1), 12(2), 13(1), 39(1), 40(1)
66000755	DRIVESHAFT KIT GUPSY DRUM	2(1), 7(1), 9(1), 12(2), 13(1), 39(1), 40(1)
66840003	EMERGENCY KIT GYPSY ONLY	24(1)
66840005	EMERGENCY KIT GUPSY DRUM	25(1)
68001063	GYPSY & STRIPPER KIT (201)	28(1)
68001064	GYPSY & STRIPPER KIT (202)	29(1)
68001065	GYPSY & STRIPPER KIT (203)	30(1)
68001066	GYPSY & STRIPPER KIT (204)	31(1)
68001077	CPX4 12V MGB	32(1)
68010878	CPX4 24V MGB	33(1)

V700 Parts list

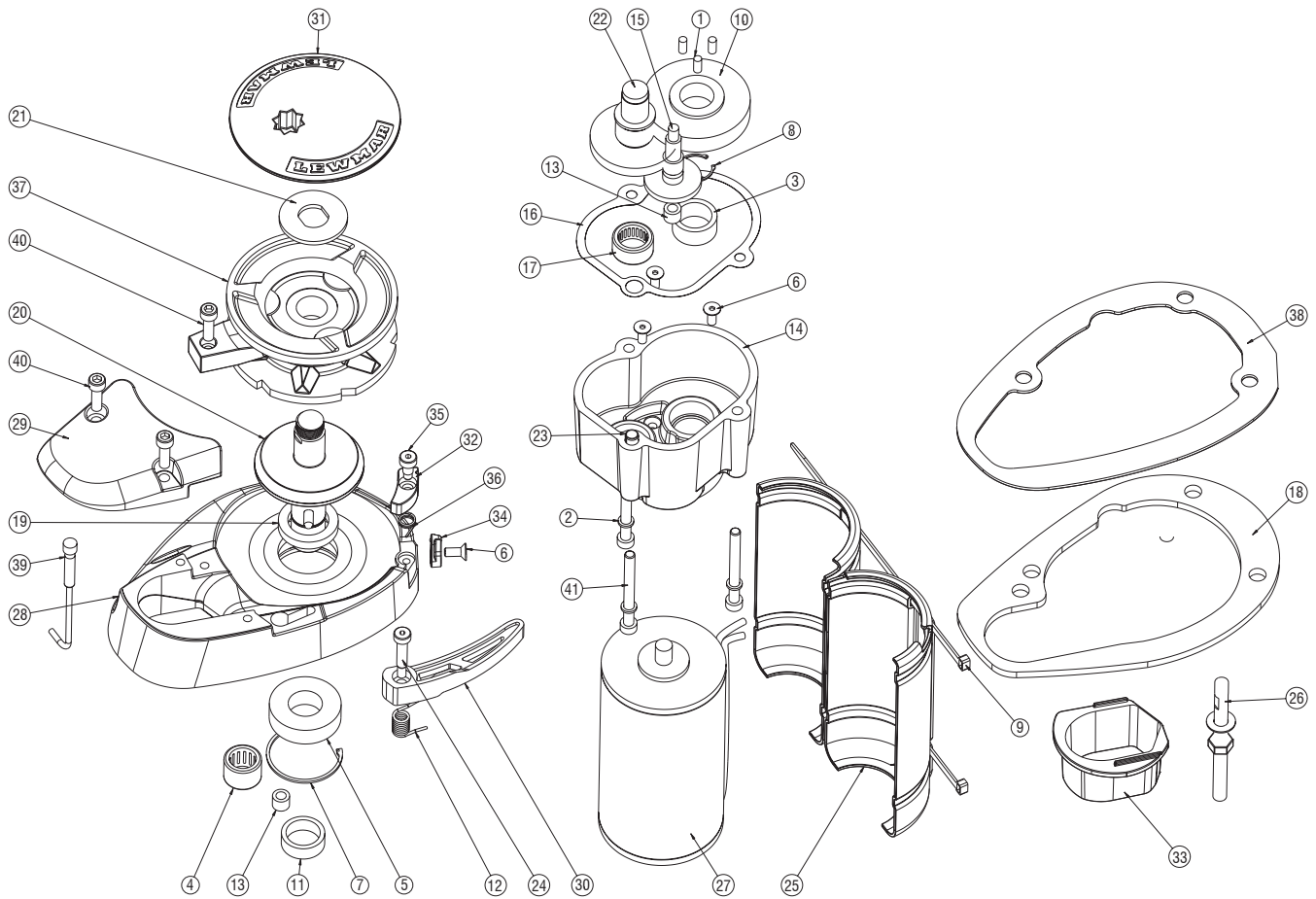

KIT NO.	KIT DESCRIPTION	ITEMS INCLUDED (QTY.)
66000099	CLUTCH LEVER	CLUTCH LEVER (1)
66000600	CONTROL ARM KIT	12(1), 24(1), 30(1)
66000601	GYPSY CAP KIT	21(1), 31(1)
66000602	MOUNTING KIT 5/16" USA	18(1), 26A(1), 33(1), 38(1)
68001024	GYPSY RC 1/4"64 @ 7MM KIT	37A(1), 40(1)
68001024	GYPSY RC 6 MM DIN 766 KIT	37B(1), 40(1)
66000605	MOUNTING KIT METRIC	18(1), 26B(1), 33(1), 38(1)
66000606	CHAIN PIPE COVER	29(1), 40(2)
66000607	FALL SAFE KIT	6(1), 32(1), 34(1), 35(1), 36(1)
66000608	BEARING/SEAL KIT	3(1), 4(1), 5(1), 7(1), 13(2), 16(1), 17(1), 19(1)
66000609	DRIVESHAFT KIT	1(3), 8(1), 11(1), 16(1), 20(1), 21(1)
66000610	MOTOR KIT	6(3), 9(2), 16(1), 25(1), 27(1)
66000611	GEARCASE COMPLETE	2(3), 3(1), 13(1), 14(1), 16(1), 17(1), 23(1), 41(3)
66000612	GEAR SET	1(3), 8(1), 10(1), 15(1), 16(1), 22(1)
66000613	COMPOUND GEAR ASSY.	16(1), 22(1)
66000614	1ST COMPOUND GEAR	15(1), 16(1)
66000615	MAGNET @ SENSOR KIT	39(1)

# I. Windlasses

## VI Parts list

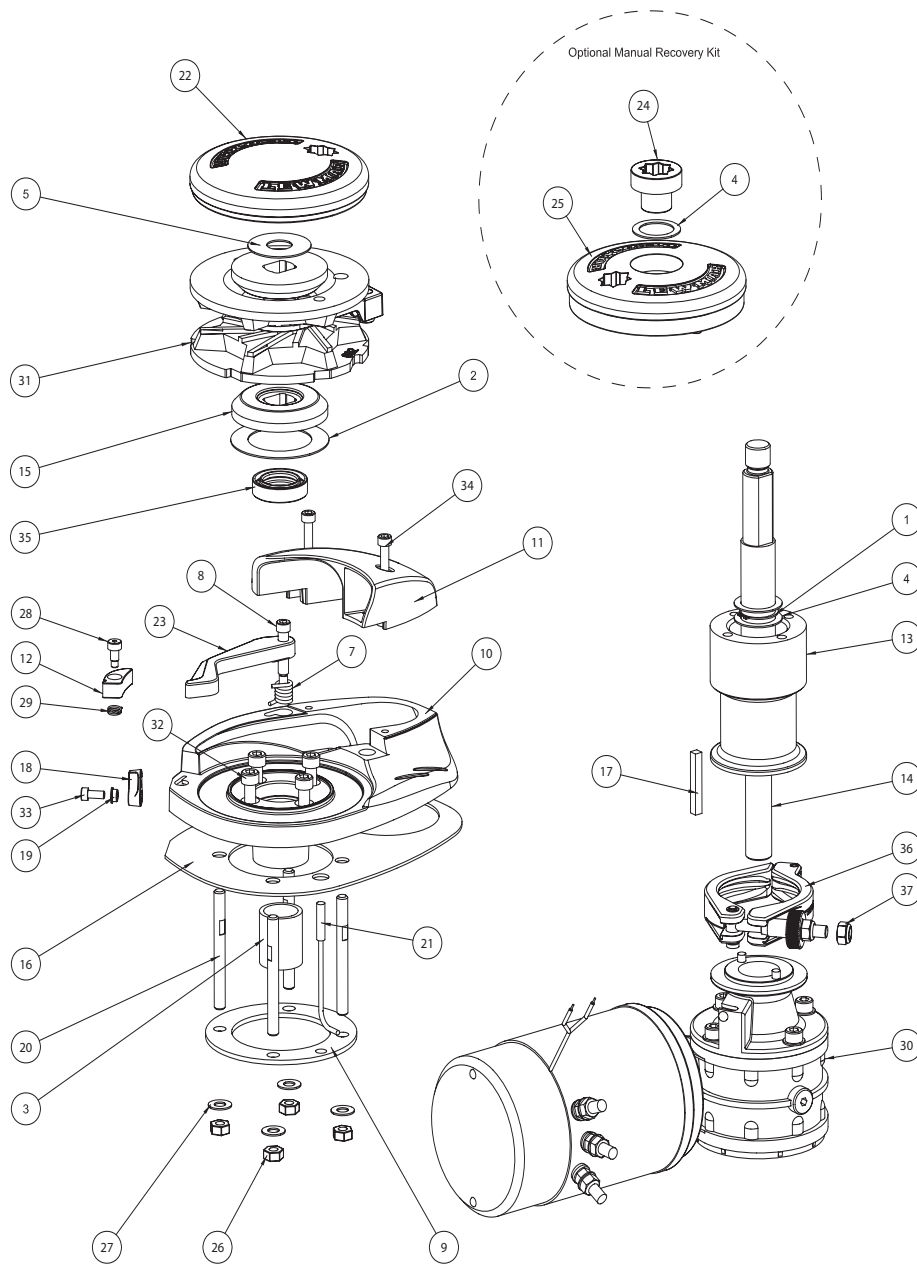

KIT NO.	KIT DESCRIPTION	ITEMS INCLUDED (QTY.)
6600060	CAP KIT	22(1)
66000624	V1/2/3 BASE	3(1), 10(1), 34(1)
66000625	CHAIN PIPE COVER	11(1), 35(2)
66000626	FASTENER KIT	1(1), 2(1), 4(3), 5(1), 8(1), 17(1), 28(1), 33(1), 34(2)
66000627	DRIVE KIT	1(1), 2(1), 3(1), 4(3), 5(1), 14(1), 15(2), 17(1), 35(1)
66000628	MANUAL RECOVERY PAWL KIT (FALL SAFE)	11(1), 17(1), 18(1), 27(1), 28(1), 32(1)
66000629	MOTOR GEARBOX	30(1)
66000631	MOUNTING KIT (METRIC)	9(1), 16(1), 20(1), 26(4), 27(4)
66000632	FAST FIT ASSEMBLY.	36(1), 37(1)
66000633	DECK SPACER KIT	13(1), 32(4)
66200076	SENSOR & MAGNET KIT	21(1), MAGNET(1)
66810030	CONTROL ARM KIT	7(1), 8(1), 23(1)
66810065	MOTOR GEARBOX KIT	17(1), 30(1), 36(1), 37(1)
66840054	MANUAL RECOVERY KIT	4(1), 24(1), 25(1)
68000360	V RANGE GYPSY & STRIPPER KIT (000)	31(1), MAGNET(1)
68000361	V RANGE GYPSY & STRIPPER KIT (001)	31A(1), MAGNET(1)
68000362	V RANGE GYPSY & STRIPPER KIT (002)	31B(1), MAGNET(1)
68000840	V RANGE GYPSY & STRIPPER KIT (006)	31C(1), MAGNET(1)

V2/3 Parts list

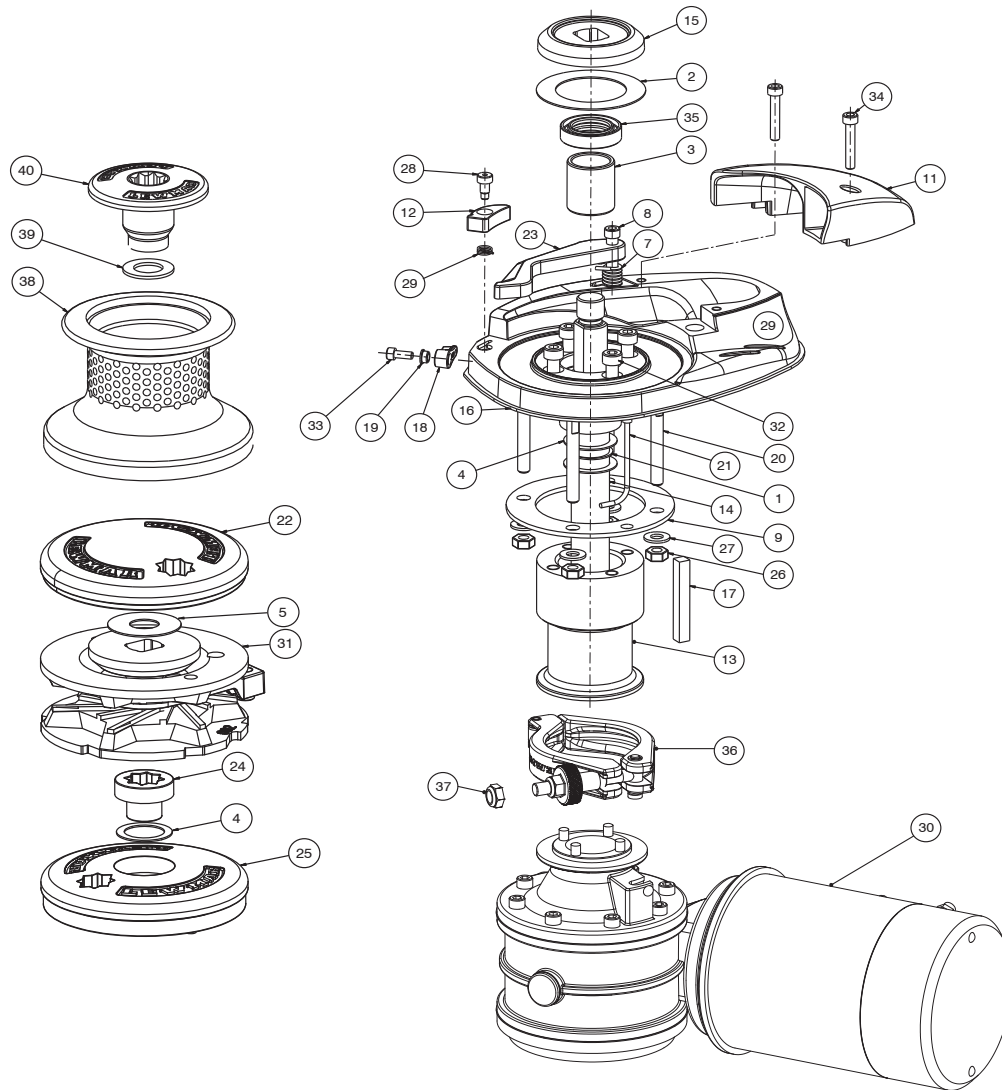

KIT NO.	DESCRIPTION	ITEMS INCLUDED (QTY.)
6600060	CAP KIT	22(1), 5(1)
66000624	V1/V2/V3 BASE	3(1), 10(1), 35(1)
66000625	CHAIN PIPE COVER	11(1), 34(2)
66000626	FASTENER KIT	1(1), 2(1), 4(3), 5(1), 6(1), 8(1), 17(1), 28(1), 33(1), 34(2)
66000641	DRIVE KIT V2/V3 GYPSY ONLY	1(1), 2(1), 3(1), 4(3), 5(1), 14(1), 15(2), 17(1), 35(1)
66000628	MANUAL RECOVERY PAWL KIT (FALL SAFE)	12(1), 18(1), 19(1), 28(1), 29(1), 33(1)
66000640	DRUM KIT V2/V3 FAST FIT	38(1), 39(1), 40(1)
6600065	DRUM TOP NUT	39(1), 40(1)
66000642	DRIVE KIT V2/V3 GYPSY DRUM	1(1), 2(1), 3(1), 4(3), 5(1), 14(1), 15(2), 17(1), 35(1)
66000631	MOUNTING KIT (METRIC)	9(1), 16(1), 20(1), 26(4), 27(4)
66000632	FAST FIT ASSEMBLY	36(1), 37(1)
66000633	DECK SPACER KIT	13(1), 32(4)
66200076	SENSOR & MAGNET KIT	21(1), MAGNET(1)
66810030	CONTROL ARM KIT	7(1), 8(1), 23(1)
66840054	MANUAL RECOVERY KIT (GYPSY ONLY)	4(1), 24(1), 25(1)
68000360	V RANGE GYPSY & STRIPPER KIT (000)	31(1), MAGNET(1)
68000361	V RANGE GYPSY & STRIPPER KIT (001)	31(1), MAGNET(1)
68000362	V RANGE GYPSY & STRIPPER KIT (002)	31(1), MAGNET(1)
68000363	V RANGE GYPSY & STRIPPER KIT (003)	31(1), MAGNET(1)
68000813	12V V2 FAST-FIT MOTOR GEARBOX ASSEMBLY	30(1), 36(1), 37(1)
68000814	24V V2 FAST-FIT MOTOR GEARBOX ASSEMBLY	30(1), 36(1), 37(1)
68000815	12V V3 FAST-FIT MOTOR GEARBOX ASSEMBLY	30(1), 36(1), 37(1)
68000816	24V V3 FAST-FIT MOTOR GEARBOX ASSEMBLY	30(1), 36(1), 37(1)
68000527	12V V2 NON - FAST-FIT MOTOR GEARBOX ASSEMBLY	30(1), 36(1), 37(1)
68000538	24V V2 NON - FAST-FIT MOTOR GEARBOX ASSEMBLY	30(1), 36(1), 37(1)
66810007	12V V3 NON - FAST-FIT MOTOR GEARBOX ASSEMBLY	30(1), 36(1), 37(1)
66810008	24V V3 NON - FAST-FIT MOTOR GEARBOX ASSEMBLY	30(1), 36(1), 37(1)
66840056	V2/V3 GYPSY/DRUM MANUAL RECOVERY KIT	NOT SHOWN

# I. Windlasses

V4/5 Parts list

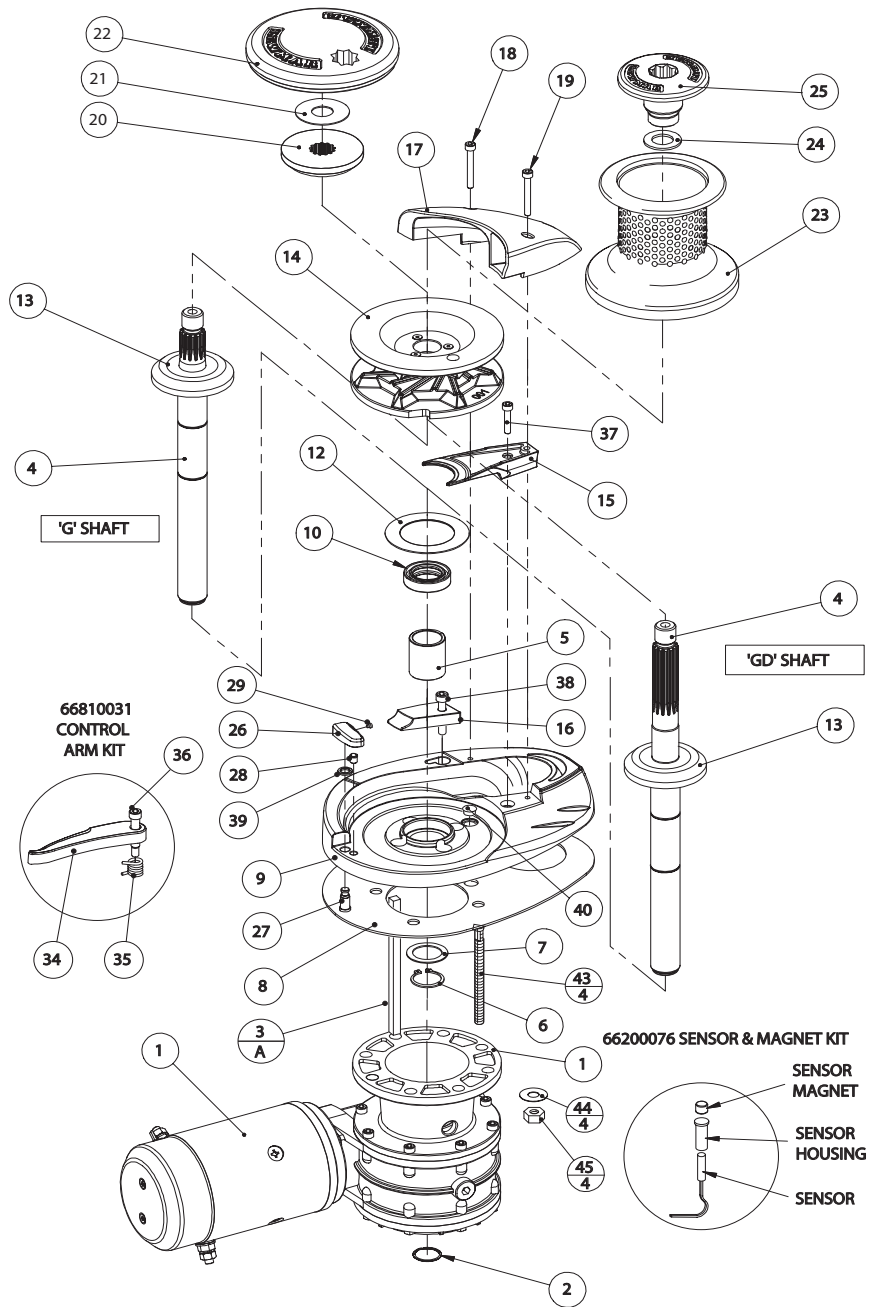

KIT NO.	KIT DESCRIPTION	ITEMS INCLUDED (QTY.)
66000065	DRUM TOP NUT	24(1), 25(1)
66000070	FASTENER/DRIVE	2(1), 3A(1), 3B(1), 6(1), 7(1), 18(1), 19(1), 21(1), 24(1), 28(1), 29(1), 32(4), 33(8), 37(1), 38(1), 40(5), 43(4), 44(4), 45(4), HEX KEYS 2, 4, 5 & 6 MM
66000071	MAINSHAFT ASSEMBLY, GYPSY/DRUM	4A(1), 13(1)
66000072	MAINSHAFT ASSEMBLY, GYPSY ONLY	4B(1), 13(1)
66000073	BEARING/SEAL	5(1), 8(1), 12(1), 12A(1)
66000075	STRIPPER/PAWL	15(1), 16(1), 26(1), 28(1), 29(1), 37(1), 38(1), 39(1), HEX KEYS 2, 4, 5 & 6 MM
66000076	BASE	5(1), 9(1)
66000077	CHAIN PIPE COVER	17(1), 18(1), 19(1), HEX KEY 5 MM
66000079	SPACER	3B(1), 30(1), 31(1), 32(4), 33(8)
66810031	CONTROL ARM KIT	34(1), 35(1), 36(1), HEX KEYS 4, 5 & 6 MM
66200076	OPTIONAL SENSOR & MAGNET	SENSOR(1), MAGNET(1) & HOUSING(1)



V6 Parts list

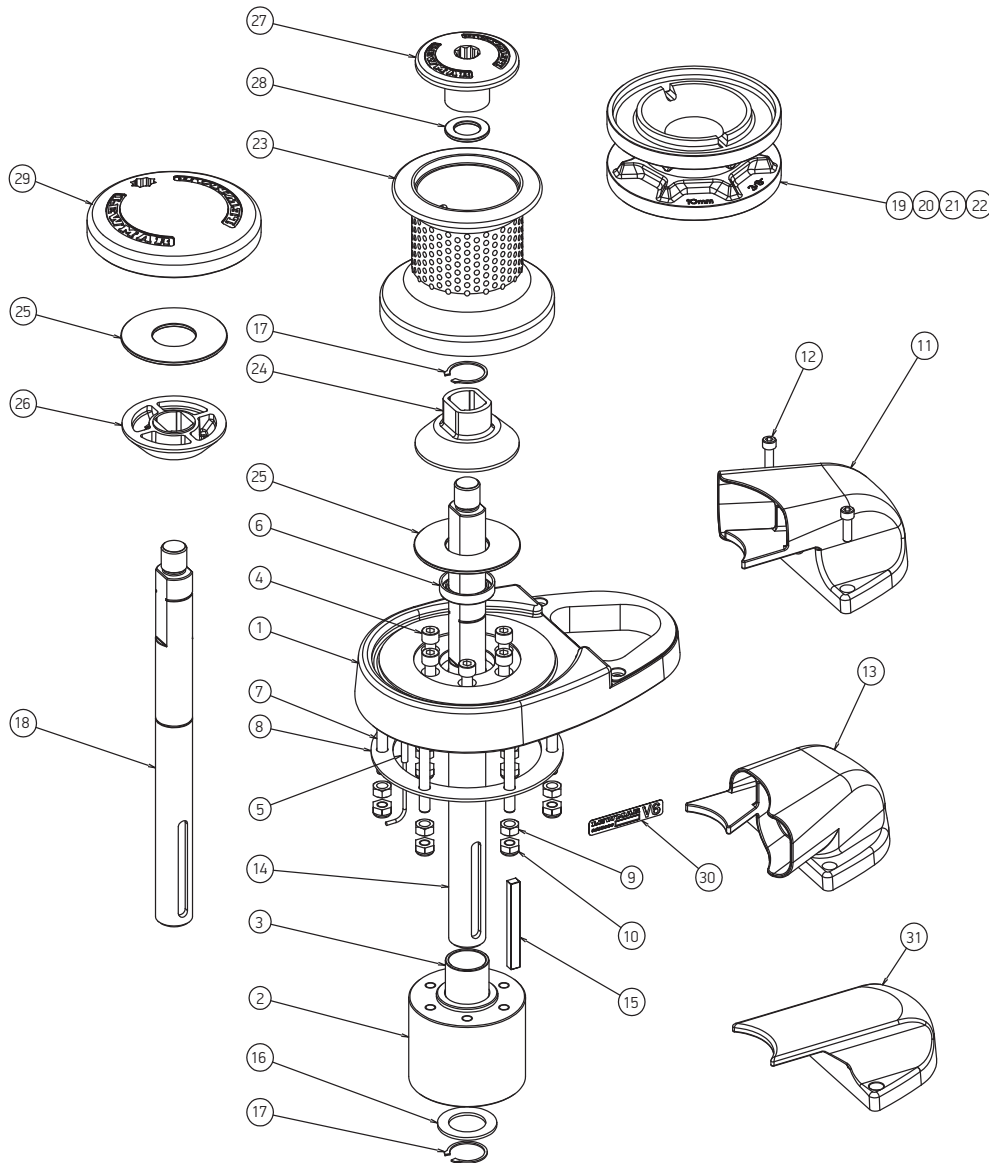

KIT NO.	KIT DESCRIPTION	ITEMS INCLUDED (QTY.)
66000692	BLANK COVER WITH STRIPPER	31(1), 12(2)
66000688	TOP CAP (GYPSY ONLY)	29(1), 25(1)
66000687	TOP NUT (GYPSY/DRUM)	27(1), 28(1)
66000686	CONE (GYPSY ONLY)	24(1), 25(2), 26(1)
66000685	CONE (GYPSY DRUM)	24(1), 25(1)
66000684	DRUM	23(1)
66000683	14 MM GYPSY	22(1)
66000682	1/2" GYPSY	21(1)
66000681	12 MM GYPSY	20(1)
66000680	10 MM GYPSY	19(1)
66000679	MAINSHAFT (GYPSY ONLY)	18(1), 15(1), 16(1), 17(2)
66000678	MAINSHAFT (GYPSY/DRUM)	14(1), 15(1), 16(1), 17(2)
66000677	R/H CHAIN COVER	13(1), 12(2)
66000676	L/H CHAIN COVER	11(1), 12(2)
66000675	MOUNTING	7(6), 8(1), 9(6), 10(6)
66000674	BASE	1(1), 2(1), 3(1), 4(6), 5(1), 6(1)

# I. Windlasses

HX1 Parts list

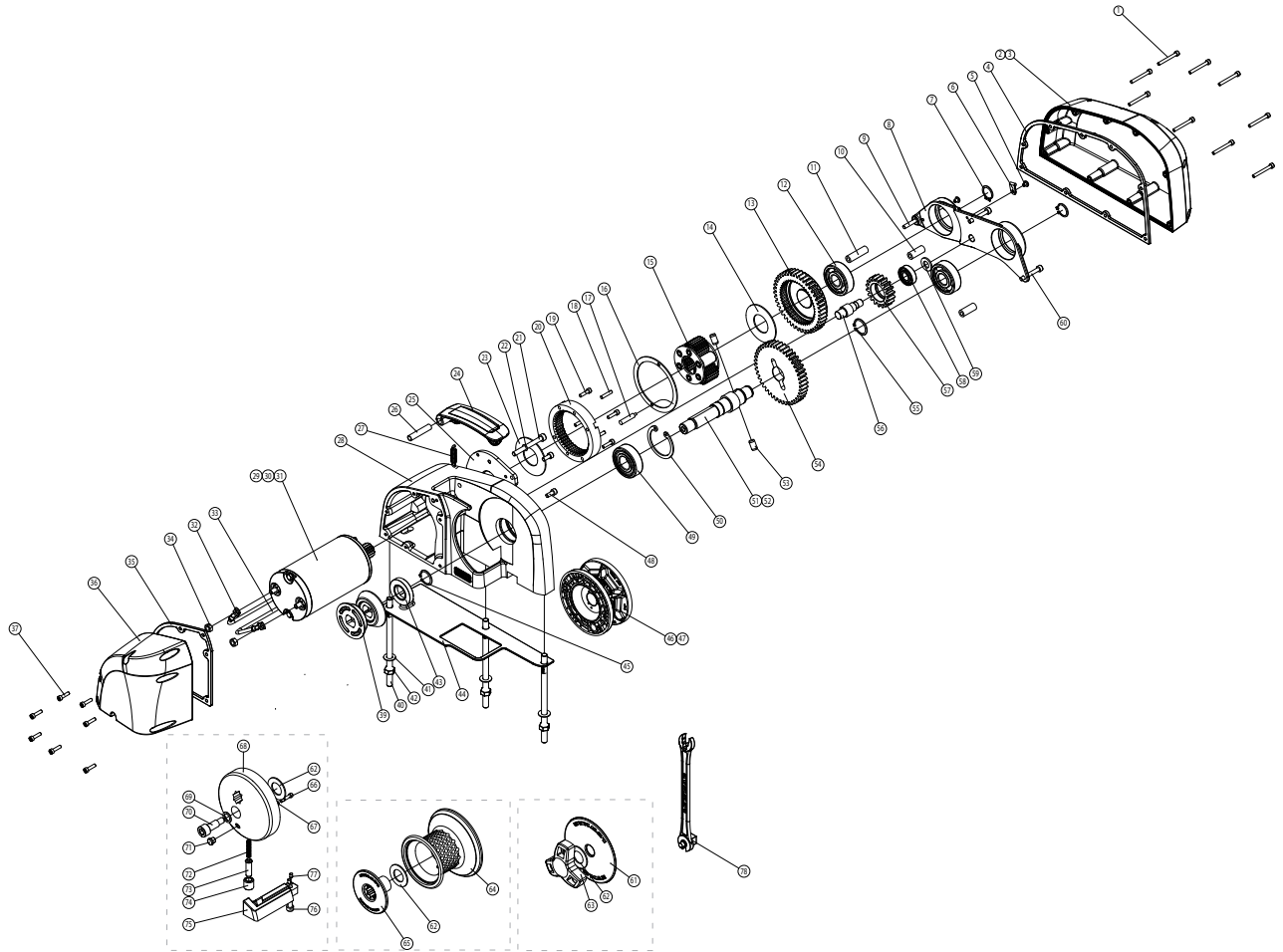

KIT NO	DESCRIPTION	ITEMS INCLUDED (QTY)
66100124	VX1 DRUM KIT	62(1), 63(1), 64(1),
66100139	VX1L/HX1 12V 500 MOTOR ASSY	29(1)
66100141	VX1L/HX1 12V 800 MOTOR ASSY	29(1)
66100142	VX1L/HX1 24V 800 MOTOR ASSY	31(1)
66140001	HX1 GASKET KIT	4(1), 35(1), 43(1)
66140002	HX1 DRIVE GO/GF KIT	12(1), 45(1), 49(1), 50(1), 51(1), 53(2), 54(1), 55(1),
66140003	HX1 DRIVE GD KIT	12(1), 45(1), 49(1), 50(1), 52(1), 53(2), 54(1), 55(1),
66140004	HX1 GEAR TRAIN ASSY 500W 12V	7(2), 8(1), 9(1), 10(2), 11(1), 12(1), 13(1), 14(1), 15(1), 16(1), 18(2), 19(4), 20(1), 23(1), 25(1), 29(1), 32(1), 33(1), 34(2), 56(1), 57(1), 58(1), 59(1), 60(2)
66140005	HX1 GEAR TRAIN ASSY 800W 12V	7(2), 8(1), 9(1), 10(2), 11(1), 12(1), 13(1), 14(1), 15(1), 16(1), 18(2), 19(4), 20(1), 23(1), 25(1), 30(1), 32(1), 33(1), 34(2), 56(1), 57(1), 58(1), 59(1), 60(2)
66140006	HX1 GEAR TRAIN ASSY 800W 24V	7(2), 8(1), 9(1), 10(2), 11(1), 12(1), 13(1), 14(1), 15(1), 16(1), 18(2), 19(4), 20(1), 23(1), 25(1), 31(1), 32(1), 33(1), 34(2), 56(1), 57(1), 58(1), 59(1), 60(2)
66140007	HX1 GYPSY CAP KIT	61(1), 62(1), 63(1)
66140008	HX1 FISH KIT	62(1), 66(1), 67(1), 68(1), 69(1), 70(1), 71(1), 72(1), 73(1), 74(1), 75(1), 76(1), 77(2)
66140009	HX1 CONTROL ARM KIT	21(1), 22(1), 24(1), 26(1)
66140010	HX1 POLYMER COVER KIT	2(1), 4(1), 35(1), 36(1)
66140011	HX1 ALLOY COVER KIT	3(1), 4(1), 35(1), 37(1)
66140012	HX1 BASE MATT ® KIT	40(3), 41(3), 42(3), 44(1), 78(1),
68140009	HX1 6/7MM 1/4" GYPSY ASSY	39(2), 46(1)
68140009	HX1 8MM GYPSY ASSY	39(2), 47(1)

Pro - Series/Fish Parts list

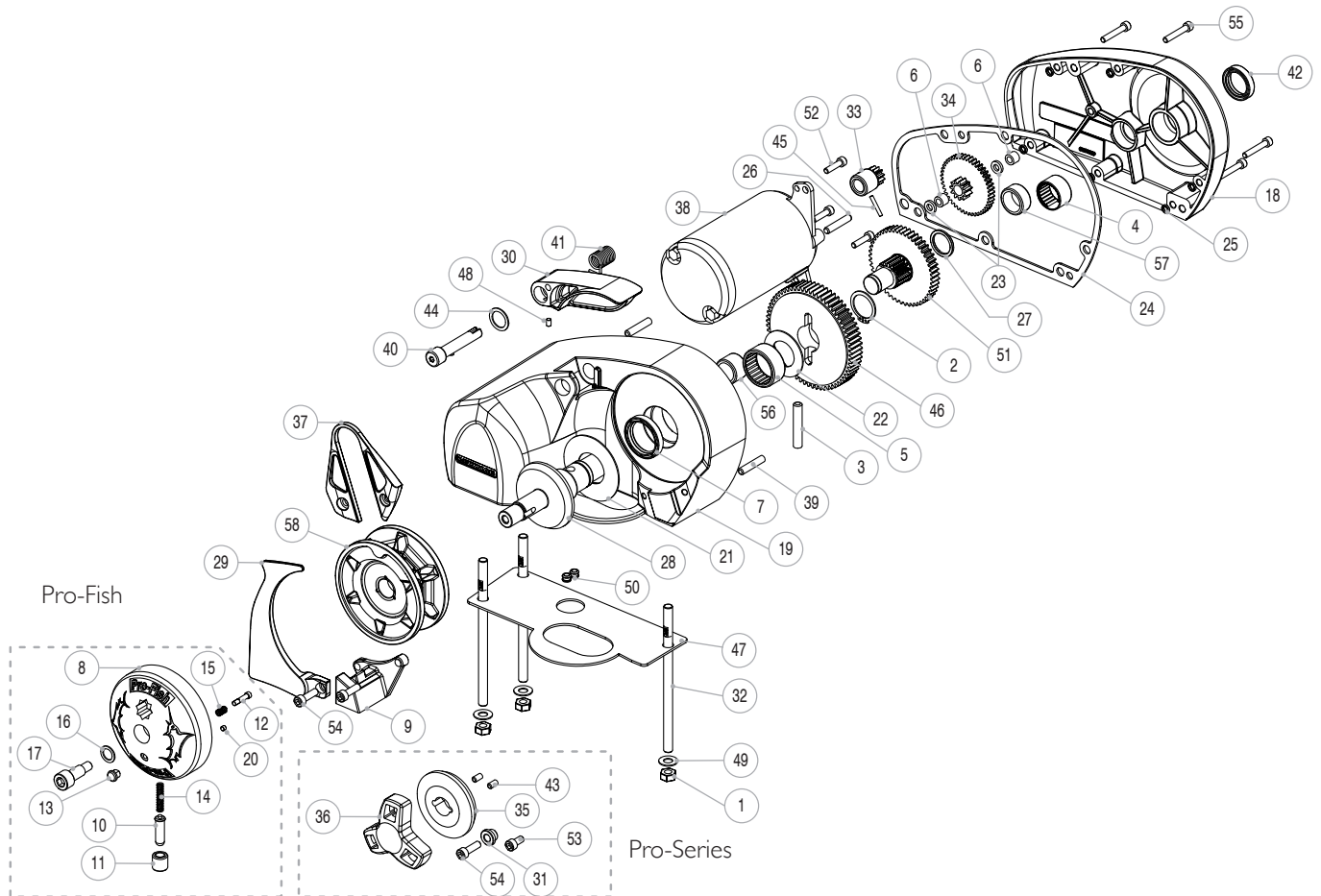

KIT NO	DESCRIPTION	ITEMS INCLUDED (QTY)
66000096	PRO-SERIES STRIPPER ARM KIT	37(1), 53(1), 54(2)
66000098	PRO-SERIES CLUTCH NUT & CONE KIT	35(1), 36(1), 43(2)
66000099	CLUTCH LEVER	CLUTCH LEVER (NOT SHOWN)
66000101	504 GYPSY RC 8MM (5/16")	58A(1)
66000102	516 GYPSY RC 5/16" G4	58B(1)
66000768	PB GYPSY (14-16MM LEADED LINE)	58C(1)
66000769	DUAL GYPSY RC 6MM - 7MM - 1/4"	58(1)
66000634	BEARING KIT	2(1), 4(1), 5(1), 6(2), 56(1), 57(1)
66000616	PRO-FISH CONVERSION KIT	8(1), 9(1), 10(1), 11(1), 12(1), 13(1), 14(1), 15(1), 16(1), 17(1), 20(1), 54(2)
66000617	PRO-FISH STOPPER KIT	9(3), 54(2)
66000620	PRO-FISH DRIVE CAP ASSEMBLY KIT	8(1), 10(1), 11(1), 12(1), 13(1), 14(1), 15(1), 16(1), 17(1), 20(1)
66000758	PRO-SERIES WASHER KIT	21(1), 22(1), 23(2), 27(1)
66000759	PRO-SERIES GASKET KIT	24(1), 25(6)
66000760	PRO-SERIES COUMPOUND GEAR KIT	5(1)
66000761	PRO-SERIES GEARS & SHAFT KIT	2(1), 3(1), 6(2), 23(2), 28(1), 33(1), 34(1), 45(1), 46(1), 51(1)
66000762	PRO-SERIES GEAR TRAIN COVER KIT	4(1), 18(1), 24(1), 25(6), 42(1), 55(6), 57(1)
66000763	PRO-SERIES 12V MOTOR KIT	26(1), 33(1), 38(1), 45(1), 50(2), 52(3)
66000764	PRO-SERIES SEALS & SCREW KIT	2(1), 3(1), 7(1), 24(1), 25(6), 26(1), 39(2), 42(1), 43(2), 45(1), 52(3), 53(2), 54(3), 55(6)
66000766	PRO-GUARD / CONTROL ARM KIT	29(1), 30(1), 31(1), 41(1), 44(1), 48(1), 54(3)

# I. Windlasses

## Pro-Sport Parts list

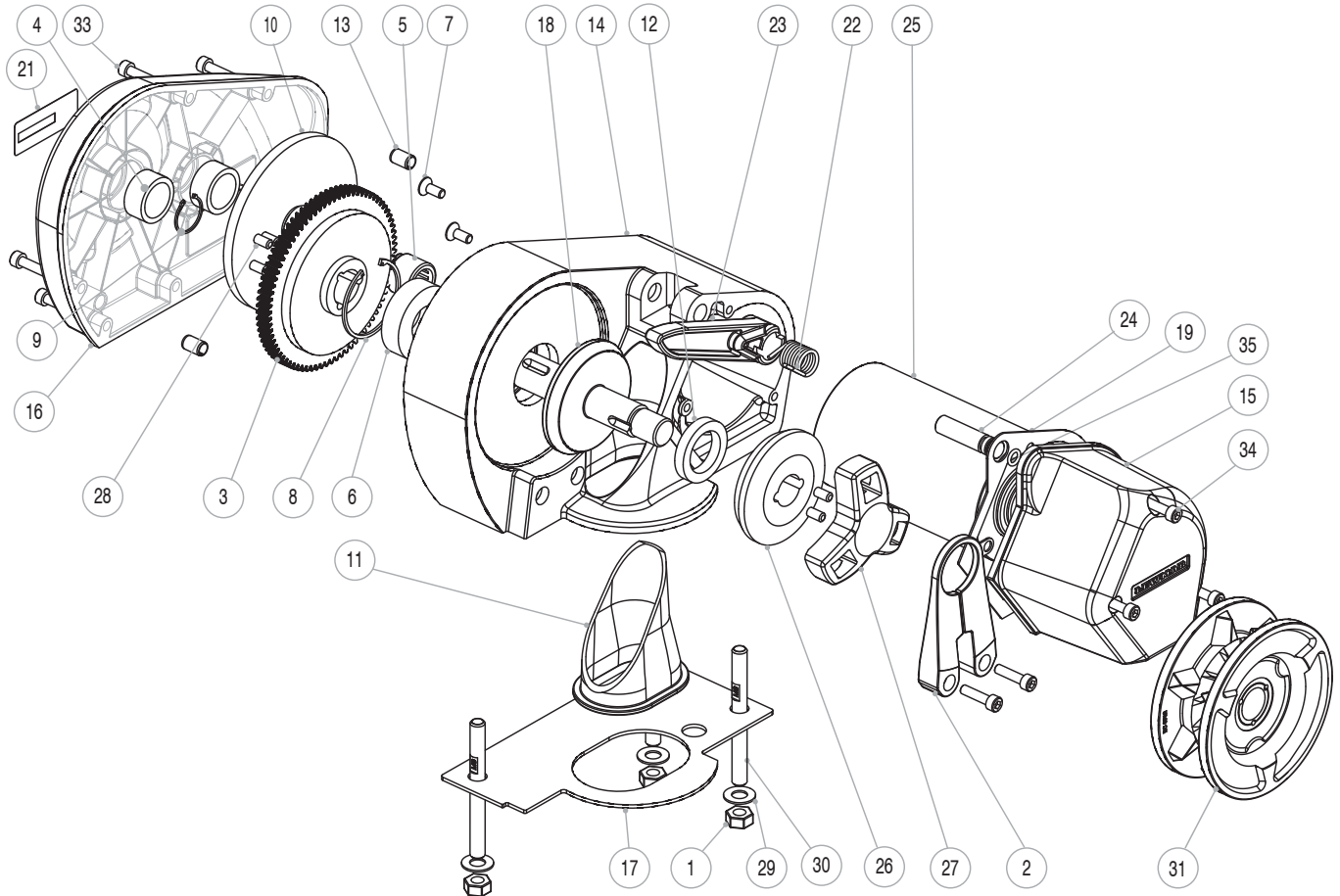

KIT NO	DESCRIPTION	ITEMS INCLUDED (QTY)
66000098	CLUTCH NUT & CONE KIT	26(1), 27(1), 28(2)
66000099	CLUTCH LEVER KIT	CLUTCH LEVER (NOT SHOWN)
66000769	GYPSY DUAL	31(1)
6052907	FLEMING, ROPE / CHAIN	2(1)
6052904	12V / 150W ELECTRIC MOTOR	25(1), 7(3)
6052945	COMPOUND GEAR ASSEMBLY	10(1)
66000643	P-SPORT FASTNER KIT	1(3), 7(3), 8(1), 9(1), 13(2), 24(1), 33(8), 34(3)
66000644	P-SPORT MOUNTING KIT	1(3), 17(1), 29(3), 30(3)
66000645	P-SPORT BEARING & SEAL KIT	4(2), 5(1), 6(1), 12(1), 35(1)
66000646	P-SPORT MAIN SHAFT KIT	9(1), 18(1), 28(5)
66000647	P-SPORT GEAR CASE KIT	4(2), 16(1)
66000648	P-SPORT MOTOR COVER KIT	15(1), 19(1)
66000649	CONTROL ARM KIT	22(1), 23(1), 24(1), 35(1)
66000650	P-SPORT GEAR KIT	3(1), 10(1), 28(3)
66000651	P-SPORT MAIN CASE	5(1), 6(1), 8(1), 12(1), 14(1),
529-075	CHAIN PIPE SLEEVE	11(1)

H2/H3 Parts list

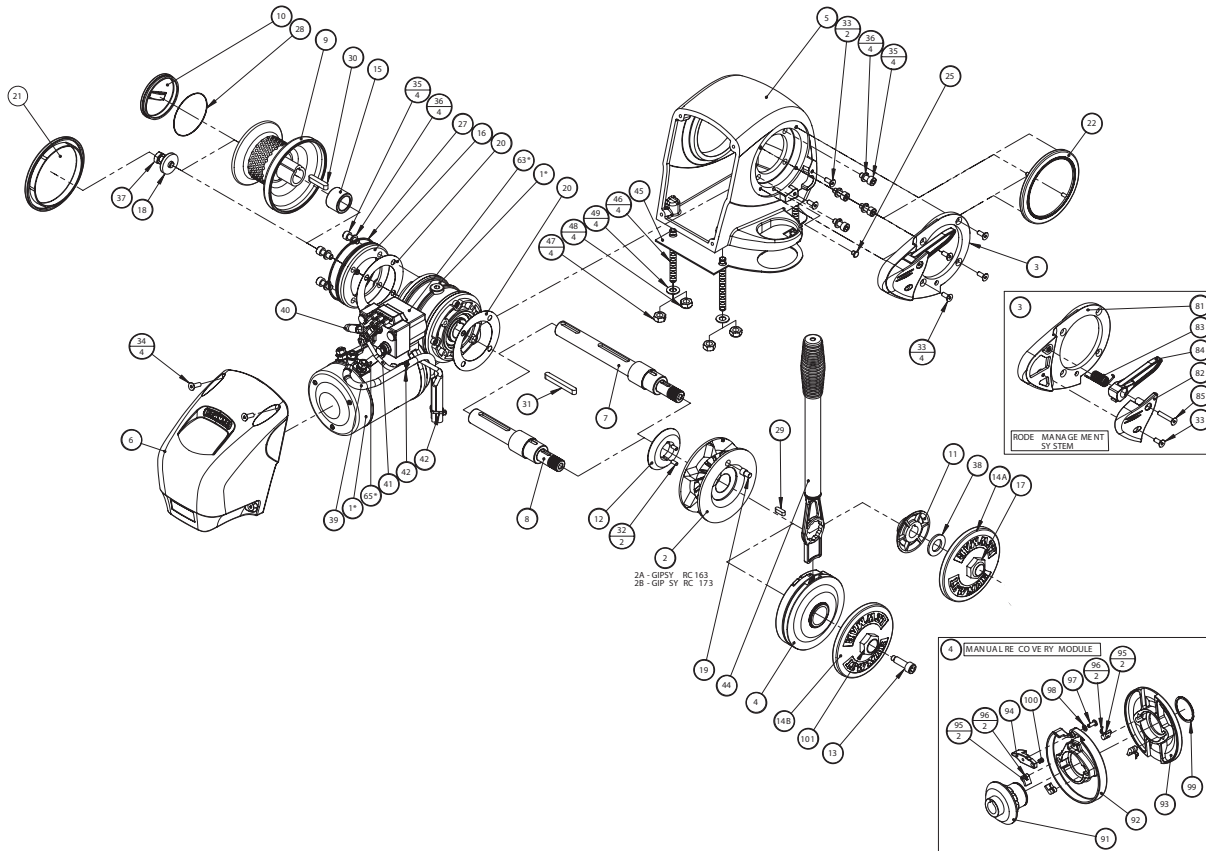

KIT NO	DESCRIPTION	ITEMS INCLUDED (QTY)
66000002	MOTOR/GEARBOX 12V H2 ASSEMBLY	1A, 68 (3), 69 (3)
66000003	MOTOR/GEARBOX 24V H2 ASSEMBLY 1B,	1B, 68 (3), 69 (3)
66000004	MOTOR/GEARBOX 12V H3 ASSEMBLY	1C, 68 (3), 69 (3)
66000005	MOTOR/GEARBOX 24V H3 ASSEMBLY	1D, 68 (3), 69 (3)
66000006	RC 10MM GYPSY ASSEMBLY (RC163)	2A
66000007	RC 8MM GYPSY ASSEMBLY (RC173)	2B
66000008	RMS MODULE	33 (5), 81, 82, 83, 84, 85
66000009	MANUAL RECOVERY MODULE	91, 92, 93, 94, 95 (4), 96 (4), 97, 98, 99, 100
66000010	FRONT CASE KIT	5, 45
66000011	REAR CASE	6
66000012	MAINSHAFT, GYPSY/DRUM	7
66000013	MAINSHAFT, GYPSY ONLY	8
66000014	DRUM	9
66000015	DRUM CAP	10
66000016	DRIVE CONE KIT	11, 12
66000017	GYPSY CAP & CLUTCH NUT ASSEMBLY, STANDARD	14A, 17
66000018	GYPSY CAP & CLUTCH NUT ASSEMBLY, MANUAL RECOVERY VERSION	14B, 101
66000019	GEARBOX SUPPORT	16
66000020	COVERPLATE KIT	21, 22
66000021	MANUAL RECOVERY OPERATING HANDLE	44
66000022	CONTACTOR KIT 12V	63A, 64
66000023	CONTACTOR KIT 24V	63B, 64
66000024	LINK SET KIT	64, 65A (PR), 65B (PR)
66000025	CONTROL ARM KIT	33, 83, 84, 85
66840045	MANUAL RECOVERY DRIVE KIT	13, 19, 94, 95 (4), 96 (4), 97, 98, 99, 100
66000027	FASTENER KIT	18, 33 (7), 34 (4), 35 (8), 36 (8), 37, 38, 45, 46 (4), 47 (4), 48 (4), 49 (4), 68 (3), 69 (3), 85
66000028	DRIVE KEY KIT	15, 29, 30, 31, 32 (2)
66000029	SEAL KIT	20 (2), 25, 27, 28
66000030	CABLE KIT	39, 40, 41, 42 (3)
OPTIONAL UPGRADE KIT TO ADD MANUAL RECOVERY		
66840045	MANUAL RECOVERY UPGRADE KIT	4, 13, 14B, 19, 44,

# I. Windlasses

S900/S2000 Parts list

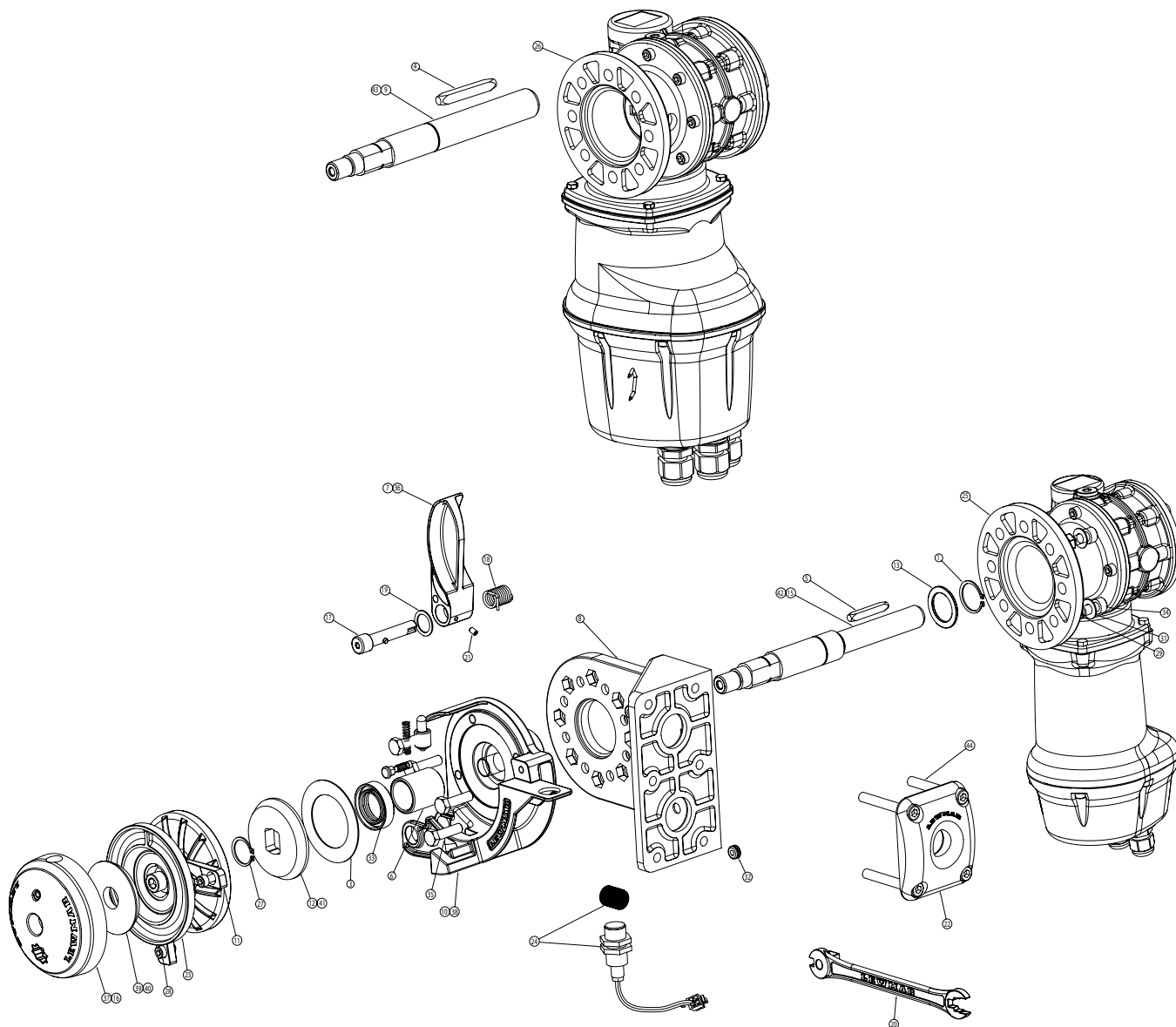

KIT NO	DESCRIPTION	ITEMS INCLUDED (QTY)
6600842	GEN 2 PORT CONTROL ARM KIT	7(1), 17(1), 18(1), 19(1), 21(1)
66000843	GEN 2 STBD CONTROL ARM KIT	36(1), 17(1), 18(1), 19(1), 21(1)
6600099	CLUTCH LEVER	20(1)
66000833	GEN 2 PORT DRIVE CAP	16(1)
66000832	GEN 2 STBD DRIVE CAP	37(1)
66000834	GEN 2 BULKHEAD UNIT	22(1), 44(4)
66000835	GEN 2 MOUNTING BRACKET KIT	8(1), 32(2), 35(4)
66000844	GEN 2 PORT STOPPER CAM/ ROPE GUIDE KIT	6(1), 10(1), 33(1), 35(4)
66000845	GEN 2 STBD STOPPER CAM/ ROPE GUIDE KIT	38(1), 6(1), 33(1), 35(4)
66000810	GYPSY	23(1)
66000811	STRIPPER KIT	11(1), 28(2)
66000836	GEN 2 PORT DRIVE CONE KIT	3(1), 12(1), 27(1), 39(1)
66000837	GEN 2 STBD DRIVE CONE KIT	40(1), 41(1), 3(1), 27(1)
66000839	S900 PORT DRIVESHAFT KIT	1(1), 5(1), 13(1), 15(1)
66000838	S900 STBD DRIVESHAFT KIT	42(1), 1(1), 5(1), 13(1)
66000841	S2000 PORT DRIVESHAFT KIT	1(1), 4(1), 43(1), 13(1)
66000840	S2000 STBD DRIVESHAFT KIT	4(1), 9(1), 1(1), 13(1)
66001190	AUTOSTOP	24(1)
66000816	S900 MOTOR/ GEARBOX	25(1), 35(4), 29(4), 31(4), 34(4)
66000817	S2000 MOTOR/GEARBOX	26(1), 35(4), 29(4), 31(4), 34(4)



## 2. Anchoring



With many years of anchoring experience and knowledge, Lewmar have developed anchors that ensure easy setting in a variety of seabed types. Extensive design, testing and development ensure the boater has peace of mind while at anchor.

With a wide range styles available, Lewmar anchors cater for all boat types including power and sail from 18ft – 250ft. Smaller boats can utilise our folding designs for ease of storage; larger vessels can fit an integrated Lewmar anchor and bow roller solution.

## 2. Anchoring



### The Lewmar Anchor Range

#### Page 82 Epsilon Anchor



Lewmar's new Epsilon anchor builds upon the iconic Delta® anchor's robust design and overall quality. Available in both manganese steel for the galvanised version and 316/2205 duplex steel combination for the stainless version. This new anchor is fully compatible with Lewmar bow rollers and is available in a range of sizes.

#### Page 84 LFX Anchor



The new LFX anchor has been developed to complement our existing range of anchors, offering a stylish and practical design. The LFX features large alloy flukes to ensure high holding power at a greatly reduced weight.

Foldable for easy stowage, the LFX is an ideal solution for smaller vessels.

#### Page 86 Delta® Anchor



The Delta® anchor is constructed of high-grade manganese steel and duplex stainless steel for maximum tensile strength. Its unique shank profile and ballasted tip make it self-launching, and its low centre of gravity and self-righting geometry ensure that it will set immediately.

Consistent and reliable in performance, the Delta® anchor is guaranteed for life against breakage<sup>1</sup>, is Lloyd's Register, high holding power approved<sup>2</sup> and is specified as the primary anchor used by numerous National Lifeboat organizations.

#### Page 88 DTX anchor



Lewmar's DTX anchor fills the gap between the galvanised and stainless Delta® anchors, allowing boat owners to choose a stainless anchor:

The DTX brings the improved aesthetics and anti-corrosion qualities of stainless steel anchors to the mass market.



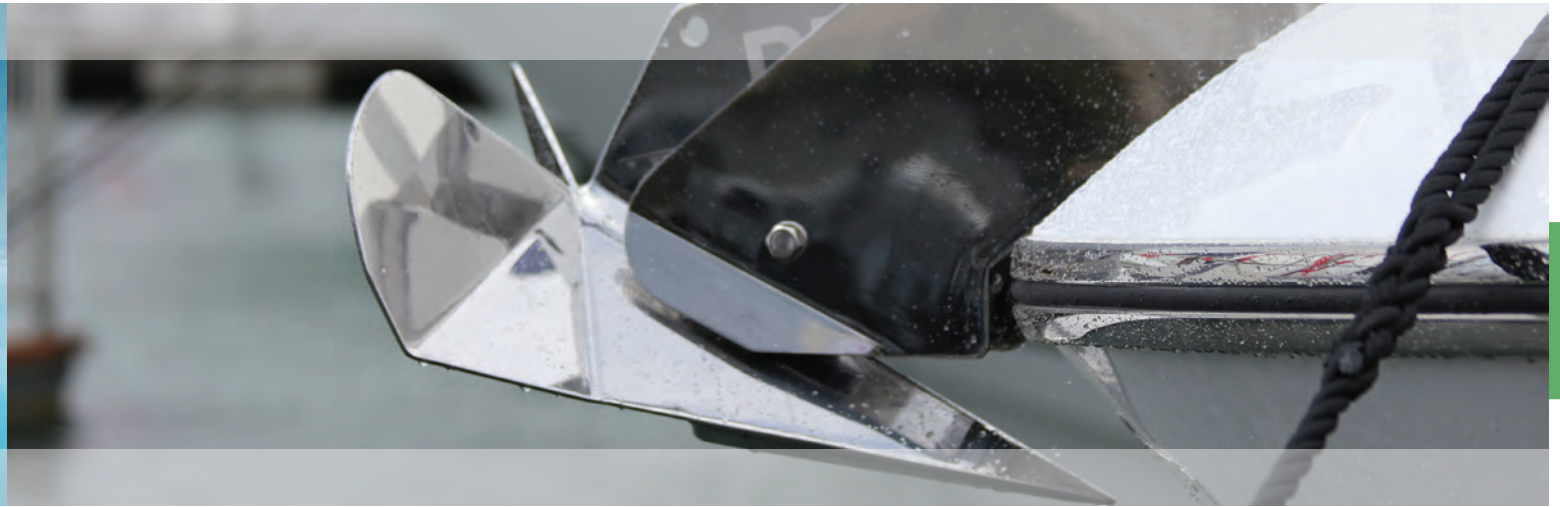

### Page 90 CQR® Anchor

The CQR® anchor has gained an industry-leading reputation for its superior performance. The original drop-forged construction of the CQR® anchor increases its strength and reliability under load. Its hinged shank delivers consistent setting and holding even in the very worst conditions. The CQR® anchor is guaranteed for life against breakage<sup>1</sup> and is Lloyd's Register, high holding power approved<sup>2</sup>.



### Page 92 Claw Anchor

Design based on anchors used to secure oil rigs in the North Sea. The Claw anchor is constructed of high-grade galvanised or stainless steel cast in a single piece. It sets effortlessly, holds in a variety of seabeds and stows easily on the bow roller of most boats.



### Page 94 LFF Anchor

Being a lightweight simple anchor, the LFF anchor is a strong secondary anchor to have on-board. A folding design provides simple stowage and different anchoring possibilities.



### Page 96 Kedge Anchor

Our Lewmar Kedge anchors are available in a range of sizes and galvanised or stainless steel. For larger yachts, the Kedge anchor is seen in twin, through-hull installations.

<sup>1</sup> Damage by deformation or bending is not covered by this guarantee.  
<sup>2</sup> Lloyd's Test Certificate is available for individual anchors by arrangement.

## 2. Anchoring



### Epsilon Anchor

The Epsilon super-high holding power anchor builds upon the legendary Delta<sup>®</sup> anchor's robustness and quality. Its concave fluke and ballast keel ensure market-leading holding power and rapid setting, while maintaining self-launching characteristics with Lewmar bow rollers and retaining the same shank geometry as the original Delta<sup>®</sup>.

Time-proven materials are used throughout the range: manganese steel or 316 stainless steel for maximum strength.

- Super-High Holding Power
- Galvanised and stainless steel versions
- Anti-snagging design
- Optional roll bar for sailboat application
- Full range from 6kg – 63kg
- Ballasted tip for fast setting
- Fully compatible with Lewmar bow rollers
- ABS and Lloyds approved



Stainless Steel  
Epsilon Anchor



Galvanized  
Epsilon Anchor



Optional roll bar



<sup>1</sup>Damage by deformation or bending is not covered by this guarantee

<sup>2</sup>Lloyd's Test Certificate available of individual Epsilon anchors by arrangement – please speak to your Lewmar representative



### Selection guide

ANCHOR WEIGHT		BOAT LENGTH OVERALL									
KG	LB	6 M 20 FT	9.2 M 30 FT	12.2 M 40 FT	15.2 M 50 FT	18.3 M 60 FT	21.3 M 70 FT	24.4 M 80 FT	27.4 M 90 FT		
6	14										
10	22										
16	35										
20	44										
25	55										
32	70										
40	88										
50	110										
63	140										

Lighter shading represents the upper limit of model. If in doubt, move up a model.  
This information is for guidance only, please consult the relevant Classification Society for specific certification requirements.

### Dimensions Diagram

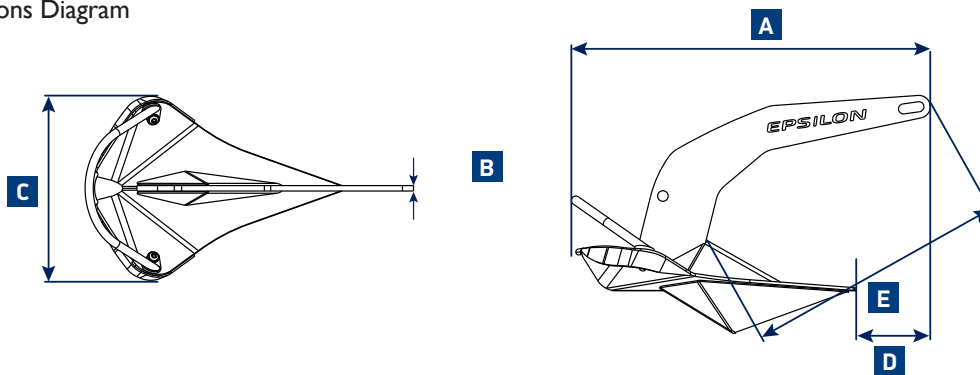

### Epsilon™ Anchor Specifications

GALVANIZED	STAINLESS	ANCHOR WEIGHT		RECOMMENDED CHAIN SIZE		A		B		C		D		E	
		KG	LB	MM	IN	MM	IN	MM	IN	MM	IN	MM	IN	MM	IN
0057606	0057506	6	14	6-7	1/4	483	19	8	5/16	271	10 2/3	258	10 1/6	337	13 1/4
0057610	0057510	10	22	8	5/16	573	22 5/8	10	3/8	332	13	306	12	401	15 4/5
0057616	0057516	16	35	8	5/16	670	26 3/8	12	1/2	376	14 4/5	358	14	469	18 1/2
0057620	0057520	20	44	10	3/8	720	28 1/3	12	1/2	406	16	387	15 1/4	505	19 7/8
0057625	0057525	25	55	10	3/8	778	30 5/8	16	5/8	438	17 1/4	417	16 3/7	545	21 1/2
0057632	0057532	32	70	10	3/8	839	33	16	5/8	474	18 2/3	452	17 4/5	590	23 2/5
0057640	0057540	40	88	10	3/8	907	35 5/7	20	3/4	512	20 1/6	486	19 1/7	636	25
0057650	0057550	50	110	12	1/2	974	38 1/3	20	3/4	550	21 2/3	519	20 3/7	680	26 7/5
0057663	0057563	63	140	12	1/2	1049	41 2/7	22	7/8	595	23 3/7	562	22 1/8	736	29

Dimensions may subject to change

## 2. Anchoring

# LFX

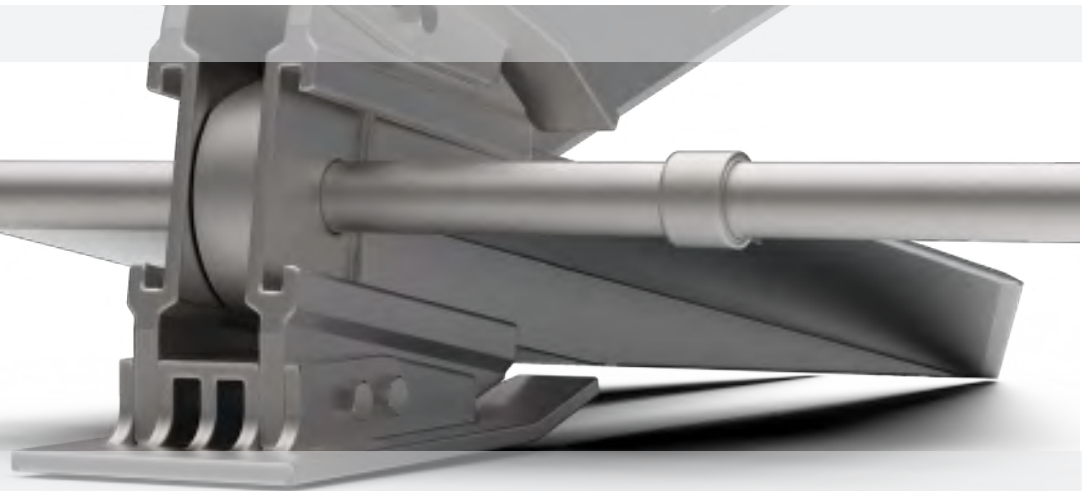

### LFX Anchor

The new LFX anchor has been developed to complement our existing range, offering style with practicality. Made from high-grade anodised aluminium, the LFX anchor demonstrates exceptional anti-corrosion performance with enhanced aesthetics. The large flukes perform superbly under high loads while being extremely lightweight, making the LFX easy to handle and use. The anchor has the additional feature of being simple to disassemble and store in a locker.

- Made from lightweight and strong, high-grade aluminium alloy
- Tough, durable and corrosion-resistant anodised finish
- Performs at its best in mud and sand environments
- Super high holding power
- Adjustable fluke angle for different conditions
- Easily detachable for locker storage (minimal tools required)
- Weight range – 4lb, 7lb, 10lb, 15lb and 21lb
- ABS and Lloyds approved

PART NO.	DESCRIPTION
0058102	LFX-4 1.8KG/4LBS
0058103	LFX-7 3.2KG/7LBS
0058105	LFX-10 4.5KG/10LBS
0058107	LFX-15 6.8KG/15LBS
0058110	LFX-21 9.5KG/21LBS



#### Certification:

Type approved with the ABS (American Bureau of Shipping).





### Selection guide

ANCHOR WEIGHT		BOAT LENGTH OVERALL					
KG	LB	5 M 16 FT	8 M 28 FT	10 M 33 FT	12 M 39 FT	14 M 46 FT	16 M 52 FT
1.8	4						
3.2	7						
4.5	10						
6.8	15						
9.5	21						

Lighter shading represents the upper limit of model. If in doubt, move up a model.

This information is for guidance only, please consult the relevant Classification Society for specific certification requirements.

### Dimensions Diagram

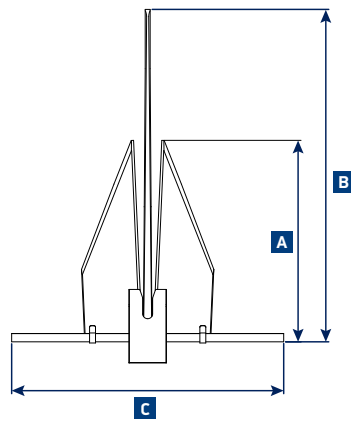

### LFX Anchor Specifications

PART NUMBER	BAG PARTO NUMBER	ANCHOR WEIGHT		RECOMMENDED CHAIN SIZE		A		B		C	
		KG	LB	MM	IN	MM	IN	MM	IN	MM	IN
0058102	0058302	1.8	4	6	1/4	342	13 1/2	565	22 1/4	462	18 1/5
0058103	0058303	3.2	7	6 TO 7	1/4	407	16	672	26 4/9	550	21 2/3
0058105	0058305	4.5	10	8	5/16	452	17 4/5	746	29 3/8	610	24
0058107	0058307	6.8	15	10	3/8	517	20 1/3	853	33 4/7	699	27 1/2
0058110	0058310	9.5	21	10	3/8	579	22 4/5	954	37 4/7	781	30 3/4

Dimensions subject to +/- 5% tolerance

## 2. Anchoring



**DELTA**  
PATENTED DESIGN

### Delta<sup>®</sup> Anchor

The market-leading Delta<sup>®</sup> anchor is constructed of high-grade manganese steel or Duplex stainless steel for maximum strength. Its unique shank profile and ballasted tip make it self-launching, and its low centre of gravity and self-righting geometry ensure that it will set immediately. Consistent and reliable in performance, the Delta<sup>®</sup> anchor is guaranteed for life against breakage<sup>1</sup> along with Lloyd's Register high holding power accreditation<sup>2</sup>.

- Proven performance
- Lead ballasted tip for fast setting
- High Holding Power
- Suited to a wide range of sea beds
- Available in Galvanized and Stainless steel
- Full range from 4kg-63kg



Stainless Steel  
Delta<sup>®</sup> Anchor

Galvanized  
Delta<sup>®</sup> Anchor



<sup>1</sup>Damage by deformation or bending is not covered by this guarantee.

<sup>2</sup>Lloyd's Test Certificate is available for individual Delta<sup>®</sup> anchors by arrangement.



### Selection guide

ANCHOR WEIGHT		BOAT LENGTH OVERALL									
KG	LB	6 M 20 FT	9.2 M 30 FT	12.2 M 40 FT	15.2 M 50 FT	18.3 M 60 FT	21.3 M 70 FT	24.4 M 80 FT	27.4 M 90 FT		
4	9	█									
6	14	█									
10	22		█								
16	35		█								
20	44			█							
25	55				█						
32	70				█						
40	88					█					
50	110						█				
63	140							█			

Lighter shading represents the upper limit of model. If in doubt, move up a model.

This information is for guidance only, please consult the relevant Classification Society for specific certification requirements.

### Dimensions Diagram

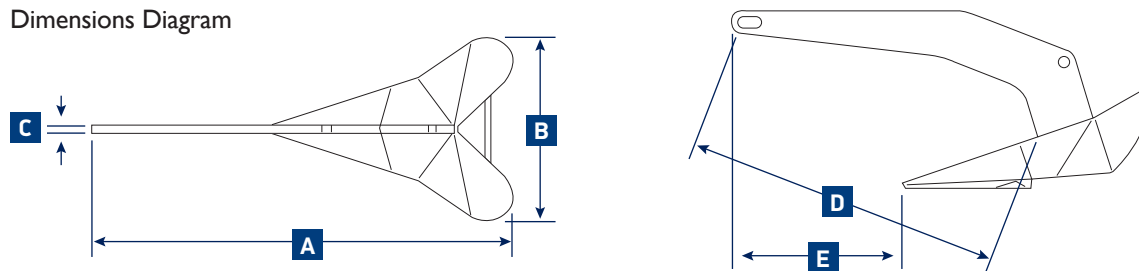

### Delta® Anchor Stainless and Galvanised Specifications

GALVANIZED	STAINLESS	ANCHOR WEIGHT		RECOMMENDED CHAIN SIZE		A		B		C		D		E	
		KG	LB	MM	IN	MM	IN	MM	IN	MM	IN	MM	IN	MM	IN
0057404	-	4	9	6-7	1/4	514	20 1/4	228	9	8	5/16	387	15 1/4	210	8 1/4
0057406	0057306	6	14	6-7	1/4	595	23 3/8	263	10 3/8	10	3/8	450	17 5/8	241	9 1/2
0057410	0057310	10	22	8	5/16	695	27 3/8	308	12 1/8	12	1/2	526	20 5/8	283	11 1/8
0057416	0057316	16	35	8	5/16	812	32	360	14 1/8	12	1/2	614	24 1/8	334	13
0057420	0057320	20	44	10	3/8	877	34 1/2	389	15 1/4	16	5/8	663	26 1/8	361	14 1/4
0057425	0057325	25	55	10	3/8	945	37 1/4	417	16 3/8	16	5/8	713	28	384	15 1/8
0057432	0057332	32	70	10	3/8	1026	40 3/8	455	17 7/8	16	5/8	774	30 1/2	417	16 3/8
0057440	0057340	40	88	10	3/8	1099	43 1/4	489	19 1/4	20	3/4	835	32 7/8	446	17 1/2
0057450	0057350	50	110	12	1/2	1175	46 1/4	520	20 1/2	20	3/4	890	35	479	18 7/8
0057463	0057363	63	140	12	1/2	1278	50 1/4	568	22 3/8	22	7/8	973	38 1/4	518	20 3/8

Dimensions subject to +/- 2% tolerance

## 2. Anchoring



# DTX

### DTX Anchor

The DTX anchor fills the gap between the existing galvanised and stainless Delta<sup>®</sup> anchors, allowing boat owners and builders to specify a more cost-effective stainless steel anchor.

Made from 316 stainless steel, the DTX anchors feature exceptional anti-corrosion performance and enhanced aesthetics. Utilising lead ballast encapsulated within the tip of the anchor to achieve the perfect centre of gravity, the DTX offers the initial bite and holding reliability that users of our Delta<sup>®</sup> anchors have come to expect.

- 316 stainless steel
- Proven performance
- Lead-ballasted tip for fast setting
- 3 year warranty
- Ordinary Holding Power
- Full range from 6kg-63kg



Stainless Steel  
DTX Anchor





### Selection guide

ANCHOR WEIGHT		BOAT LENGTH OVERALL							
KG	LB	6 M 20 FT	9.2 M 30 FT	12.2 M 40 FT	15.2 M 50 FT	18.3 M 60 FT	21.3 M 70 FT	24.4 M 80 FT	27.4 M 90 FT
6	14	■							
10	22	■							
16	35		■						
20	44			■					
25	55				■				
32	70					■			
40	88						■		
50	110							■	
63	140								■

Lighter shading represents the upper limit of model. If in doubt, move up a model.

This information is for guidance only, please consult the relevant Classification Society for specific certification requirements.

### Dimensions Diagram

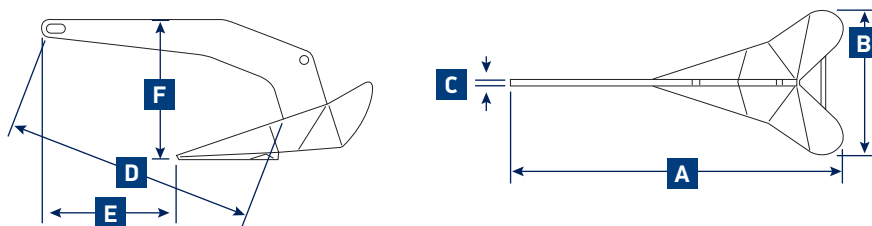

### DTX Anchor Specifications

PART NUMBER	ANCHOR WEIGHT		RECOMMENDED CHAIN SIZE		A		B		C		D		E		F	
	KG	LB	MM	IN	MM	IN	MM	IN	MM	IN	MM	IN	MM	IN	MM	IN
0057206	6	14	6-7	1/4	593	23 3/8	265	10 7/16	10	3/8	450	17 5/8	243	9 1/2	254	10
0057210	10	22	8	5/16	695	27 3/8	310	12 7/32	13	1/2	526	20 5/8	282	11 1/8	292	11 1/2
0057216	16	35	8	5/16	812	32	362	14 1/4	13	1/2	614	24 1/8	328	13	339	13 3/8
0057220	20	44	10	3/8	877	34 1/2	392	15 7/16	16	5/8	663	26 1/8	357	14	368	14 1/2
0057225	25	55	10	3/8	945	37 1/4	415	16 3/8	16	5/8	713	28	387	15 1/4	398	15 5/8
0057232	32	70	10	3/8	1023	40 1/4	453.5	17 7/8	20	3/4	775	30 1/2	425	16 3/4	432	17
0057240	40	88	10	3/8	1103	43 7/16	489	19 1/4	20	3/4	883	32 3/4	437	17 1/4	461	18 1/8
0057250	50	110	12	1/2	1175	46 1/4	523	20 5/8	20	3/4	890	35	479	18 7/8	486	19 1/8
0057263	63	140	12	1/2	1270	50	567	22 5/16	25	1	963	38	508	20	537	21 1/8

Dimensions subject to +/- 2% tolerance

## 2. Anchoring



### CQR® Anchor

The CQR® anchor has gained legendary status for its superior performance. The construction of the CQR® anchor increases its strength and reliability under load – a genuine CQR® anchor will not break. Its hinged shank delivers consistent setting and holding even in the very worst conditions. The CQR® anchor is guaranteed for life against breakage<sup>1</sup> and has Lloyd's Register General Approval of an Anchor Design<sup>2</sup> as a High Holding Power anchor.



Galvanized  
CQR® Anchor

Stainless Steel  
CQR® Anchor

#### Selection guide

ANCHOR WEIGHT		BOAT LENGTH OVERALL				
KG	LB	6 M 20 FT	12.2 M 40 FT	18.3 M 60 FT	24.4 M 80 FT	30.5 M 100 FT
7	15	█				
9	20		█			
11	25		█			
16	35		█			
20	44		█			
27	60		█			
34	75		█			
48	105		█			
66	140		█			
81	180		█			
108	240		█			
137	300		█			
182	400		█			
227	500		█			
273	600		█			

For larger vessel, Lewmar recommend to follow the recommendation given by the relevant Classification Societies, based on the 'Equipment Number' of the vessel

Lighter shading represents the upper limit of model. If in doubt, move up a model.

This information is for guidance only, please consult the relevant Classification Society for specific certification requirements.



### Dimensions Diagram

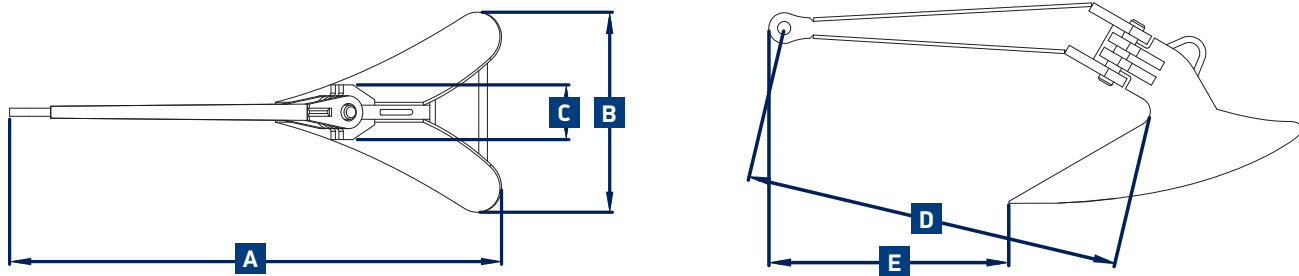

### CQR® Anchor Stainless and Galvanised Specifications

GALVANIZED	STAINLESS	ANCHOR WEIGHT		RECOMMENDED CHAIN SIZE		A		B		C		D		E	
		KG	LB	MM	IN	MM	IN	MM	IN	MM	IN	MM	IN	MM	IN
0056503W	-	7	15	6	1/4	626	24 5/8	253	10	82	3 1/4	439	17 1/4	287	11 1/4
0056504W	-	9	20	8	5/16	690	27 1/8	279	11	86	3 3/8	484	19	313	12 3/8
0056505W	-	11	25	8	5/16	740	29 1/8	299	11 6/8	90	3 1/2	522	20 1/2	336	13 1/4
0056506W	-	16	35	8	5/16	827	32 1/2	335	13 2/8	94	3 3/4	584	23	373	14 5/8
0056507W	-	20	44	10	3/8	901	35 3/8	366	14 3/8	100	3 7/8	635	25	405	16
0056508W	0056205	27	60	10	3/8	989	38 7/8	402	15 7/8	106	4 1/8	700	27 1/2	445	17 1/2
0056509W	0056206	34	75	11	7/16	1071	42 1/8	435	17 1/8	112	4 3/8	754	29 5/8	481	18 7/8
0056510W	0056207	48	105	11	7/16	1196	47	485	19	120	4 3/4	843	33 1/8	530	20 7/8
0056511W	0056208	63	140	12.5	1/2	1337	52 5/8	537	21 1/8	128	5	933	36 3/4	583	23
0056513W	0056209	81	180	12.5	1/2	1450	57	582	23	138	5 1/2	1010	39 3/4	634	25
0056515W	0056210	108	240	14	9/16	1560	61 1/2	641	25 1/4	146	5 3/4	1105	43 1/2	694	27 3/8
0056530W	0056211	137	300	14	9/16	1682	66 1/4	693	27 1/4	154	6	1194	47	746	29 3/8
0056540W	-	182	400	16	5/8	1865	73 1/2	763	30	164	6 1/2	1319	52	828	32 1/2
0056550W	-	227	500	17.5	11/16	2109	83	825	32 1/2	174	6 7/8	1430	56 1/4	875	34 1/2
0056560W	-	273	600	17.5	11/16	2138	84 1/8	870	34 1/4	184	7 1/4	1511	59 1/2	949	37 3/8

Dimensions subject to +/- 2% tolerance

<sup>1</sup>Damage by deformation or bending is not covered by this guarantee

<sup>2</sup>Lloyd's Test Certificate available of individual CQR anchors by arrangement – please speak to your Lewmar representative

## 2. Anchoring



### Claw Anchor

Design based on anchors used to secure oil rigs in the North Sea. The Claw anchor is constructed of high-grade steel cast in a single piece. It sets effortlessly, holds in a variety of seabeds and stows easily on the bow roller of most boats. Also ideal for twin-stacked installations.



Galvanised  
Claw



Stainless Steel  
Claw

#### Selection guide

ANCHOR WEIGHT		BOAT LENGTH OVERALL							
KG	LB	6 M 20 FT	9.2 M 30 FT	12.2 M 40 FT	15.2 M 50 FT	18.3 M 60 FT	21.3 M 70 FT	24.4 M 80 FT	27.4 M 90 FT
1	2.2	■							
2	4.4	■							
5	11		■						
7.5	16.5		■						
10	22		■						
15	33			■					
20	44			■					
30	66				■				
50	110					■			
80	176						■		

LIGHTER SHADING REPRESENTS THE UPPER LIMIT OF MODEL. IF IN DOUBT, MOVE UP A MODEL.  
THIS INFORMATION IS FOR GUIDANCE ONLY, PLEASE CONSULT THE RELEVANT CLASSIFICATION SOCIETY FOR SPECIFIC CERTIFICATION REQUIREMENTS.



### Dimensions Diagram

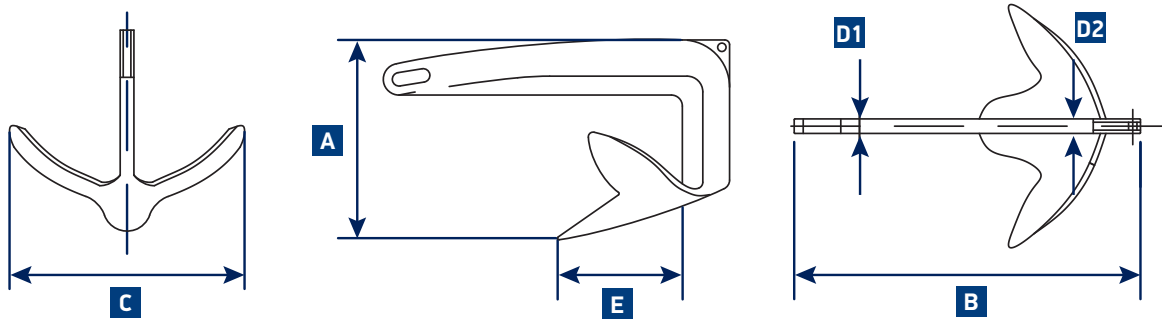

### Claw Anchor Galvanised Specifications

GALVANIZED PART NO.	ANCHOR WEIGHT		RECOMMENDED CHAIN SIZE		A		B		C		D1		E	
	KG	LB	MM	IN	MM	IN	MM	IN	MM	IN	MM	IN	MM	IN
0057901	1	2.2	5	3/16	133 ±8	5 1/4	295 ±4	11 5/8	182 ±8	7 3/16	7.5 ±2	5/16	95 ±6	3 3/4
0057902	2	4.4	5	3/16	182 ±8	7 3/16	361 ±4	14 3/16	240 ±8	9 7/16	9 ±2	3/8	123 ±6	4 13/16
0057905	5	11	5	3/16	227 ±10	8 15/16	468 ±5	18 7/16	295 ±8	11 5/8	12 ±3	1/2	150 ±6	5 7/8
0057907	7.5	16.5	6	1/4	263 ±10	10 3/8	499 ±5	19 5/8	324 ±10	12 3/4	15 ±3	9/16	151 ±8	5 15/16
0057910	10	22	8	5/16	282 ±10	11 1/8	540 ±6	21 1/4	360 ±10	14 3/16	15 ±4	9/16	182 ±8	7 3/16
0057915	15	33	8	5/16	342 ±12	13 7/16	630 ±6	24 13/16	435 ±10	17 1/8	16.5 ±4	10/16	206 ±12	8 1/8
0057920	20	44	10	3/8	343 ±12	13 1/2	703 ±8	27 11/16	452 ±12	17 13/16	25 ±5	1	238 ±12	9 3/8
0057930	30	66	10	3/8	397 ±12	15 5/8	812 ±8	31 15/16	515 ±12	20 1/4	24 ±5	5/16	283 ±12	11 1/8
0057950	50	110	12	1/2	465 ±12	18 5/16	943 ±10	37 1/8	625 ±12	24 5/8	25.5 ±5	1	313 ±12	12 3/16
0057980	80	176	12	1/2	528 ±12	20 13/16	1074 ±10	42 5/16	699 ±12	27 1/2	26 ±5	1	365 ±12	14 3/8

### Claw Anchor Stainless Specifications

STAINLESS STEEL PART NO.	ANCHOR WEIGHT		RECOMMENDED CHAIN SIZE		A		B		C		D1		D2		E	
	KG	LB	MM	IN	MM	IN	MM	IN	MM	IN	MM	IN	MM	IN	MM	IN
0058901	1	2.2	5	3/16	135 ±8	5 5/16	292 ±4	11 1/2	195 ±8	7 11/16	8 ±	5/16	10 ±2	1/2	106 ±6	4 3/16
0058902	2	4.4	5	3/16	177 ±8	6 15/16	358 ±4	14	240 ±8	9 7/16	7 ±2	1/4	9.5 ±2	3/8	127 ±6	5
0058905	5	11	5	3/16	230 ±10	9 1/16	453 ±5	17 7/8	305 ±8	12	9 ±3	1/4	14.5 ±3	5/8	146 ±6	5 3/4
0058907	7.5	16.5	6	1/4	267 ±10	10 1/2	481 ±5	18 15/16	345 ±10	13 9/16	12.5 ±3	1/2	18 ±3	11/16	138 ±8	5 7/16
0058910	10	22	8	5/16	288 ±10	11 5/16	540 ±6	21 1/4	377 ±10	14 13/16	13 ±4	1/2	19 ±4	3/4	165 ±8	6 1/2
0058915	15	33	8	5/16	332 ±12	13 1/16	625 ±6	24 5/8	448 ±10	17 3/4	15 ±4	9/16	22 ±4	14/16	203 ±12	8
0058920	20	44	10	3/8	357 ±12	14 1/16	661 ±8	26	465 ±12	18 5/16	17 ±5	3/4	25 ±5	1	220 ±12	8 11/16
0058930	30	66	10	3/8	405 ±12	15 15/16	782 ±8	30 3/16	540 ±12	21 1/4	18 ±5	11/16	26 ±5	1	265 ±12	10 7/16
0058950	50	110	12	1/2	454	17 7/8	950	37 2/5	607	23 7/8	25	1	45	1 3/4	325	12 13/16
0058980	80	176	12	1/2	545	21 7/16	1080	42 1/2	740	29 1/8	25	1	45	1 3/4	356	14

## 2. Anchoring



### LFF Anchor

For smaller yachts, the LFF anchor is ideally used as a secondary anchor as it provides great holding power, easy stowage and can be used in a number of mooring applications.

The Lewmar LFF anchor is a simple design which folds flat. It is mainly used as a secondary or stern anchor, manufactured from galvanised materials. Sizes ranging from 6 – 25kg.

- Folds flat for easy stowage
- Proven performance
- Mainly used as a secondary anchor
- Ordinary Holding Power
- Full range from 6kg - 25kg





### Selection guide

ANCHOR WEIGHT		BOAT LENGTH OVERALL					
KG	LB	6M 20 FT	9.2 M 30 FT	12.2 M 40 FT	15.2 M 50 FT	18.3 M 60 FT	
6	2.2						
8	4.4						
10	11						
12	16.5						
14	22						
16	33						
20	44						
25	66						

Lighter shading represents the upper limit of model. If in doubt, move up a model.

This information is for guidance only, please consult the relevant Classification Society for specific certification requirements.

### Dimensions Diagram

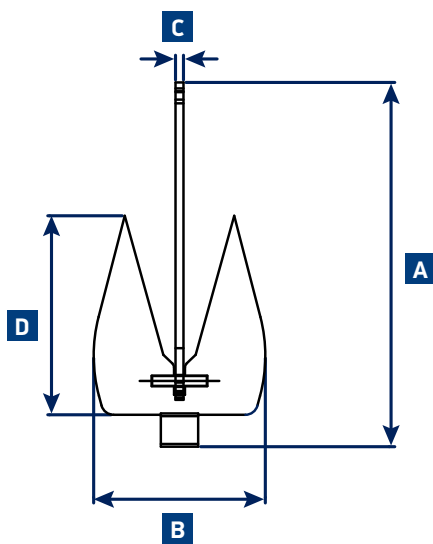

### LFF Anchor Specifications

PART NUMBER	ANCHOR WEIGHT		A		B		C		D	
	KG	LB	MM	IN	MM	IN	MM	IN	MM	IN
0057806	6	13.2	548	21 9/16	271	10 11/16	14	9/16	310	
0057808	8	17.6	645	25 3/8	312	12 5/16	14	9/16	360	
0057810	10	22	732	28 13/16	348	13 11/16	16	5/8	400	
0057812	12	26.4	785	30 7/8	348	13 11/16	18	11/16	395	
0057814	14	30.8	788	31	369	14 1/2	18	11/16	425	
0057816	16	35.2	840	33 1/16	369	14 1/2	20	13/16	420	
0057820	20	44	910	35 13/16	414	16 5/16	22	7/8	460	
0057825	25	55.1	972	38 1/4	451	17 3/4	22	7/8	495	

Dimensions subject to +/- 2% tolerance



## 2. Anchoring



### Kedge Anchor

Our Lewmar Kedge anchors are available in a variety of sizes and can be used in a number of ways. For larger yachts, the Kedge anchor is used on bow pocket installations primarily seen on superyachts. When bow anchoring the two anchors can be deployed in a Y pattern to form dual holding performance. They can also be stowed away in the bow anchor pocket, flush against the hull.

- Available in sizes 105kg – 280kg
- Proven performance
- Galvanised or stainless steel available
- Good Holding Power
- Can be used in a variety of sea beds
- Able to stow away in the bow neatly







### Selection guide

ANCHOR WEIGHT	
KG	LB
105	232
125	276
150	331
160	353
180	397
210	463
230	507
280	617

Lewmar recommend to follow the relevant Classification Societies' specifications, based on the Equipment Number of the vessel

### Dimensions Diagram

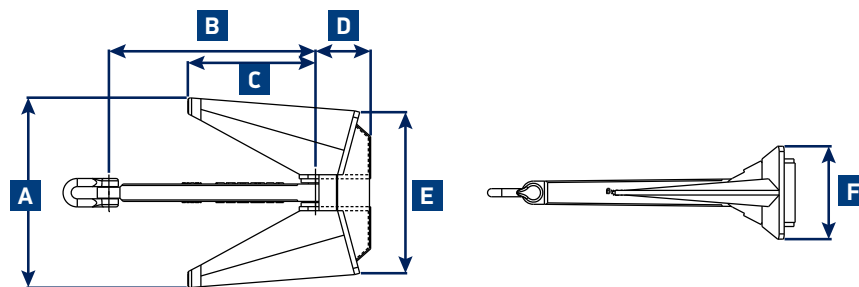

### Kedge Anchor Stainless and Galvanised Specifications

GALVANIZED PART NO.	STAINLESS PART NO.	ANCHOR WEIGHT		RECOMMENDED CHAIN SIZE		A		B		C		D		E		F	
		KG	LB	MM	IN	MM	IN	MM	IN	MM	IN	MM	IN	MM	IN	MM	IN
69000544	69000545	105	232	14	9/16	655	25 13/16	712	28 1/16	440	17 5/16	190	7 1/2	555	21 7/8	320	12 5/8
69000560	69000561	125	276	14	9/16	705	27 3/4	766	30 3/16	472	18 9/16	204	8 1/16	598	23 9/16	345	13 9/16
69000546	69000547	150	331	16	5/8	760	29 15/16	830	32 11/16	510	20 1/16	220	8 11/16	645	25 3/8	365	14 3/8
69000548	69000549	160	353	16	5/8	765	30 1/8	835	32 7/8	516	20 5/16	223	8 3/4	650	25 9/16	370	14 9/16
69000550	69000551	180	397	16	5/8	795	31 5/16	860	33 7/8	536	21 1/8	230	9 1/16	675	26 9/16	385	15 3/16
69000585	69000586	210	463	17.5	11/16	838	33	899	35 3/8	554	21 13/16	238	9 3/8	711	28	406	16
69000552	69000553	230	507	17.5	11/16	856	33 11/16	923	36 5/16	569	22 3/8	246	9 11/16	724	28 1/2	415	16 5/16

Dimensions subject to +/- 2% tolerance

## 2. Anchoring



### Devil's Claw Chain Stoppers

The Devil's Claw Chain Stopper units are designed to be used with Lewmar V8 to V12 windlass range.

- Paddles hold the load of the anchor and chain when at anchor, taking the load off the windlass
- Devil's Claw is used for tensioning the anchor chain when the anchor is stowed, preventing it from moving when under way.
- Required by classification societies at 80%, Lewmar exceed the breaking load of these units which is calculated at 125% of the breaking load of the chain.
- Stopper paddles made from high tensile 17-4PH Stainless Steel, and the main bodies are made from 316 Stainless Steel, combined with an integral high tensile 17-4PH Stainless Steel stopper block.
- Available in horizontal & vertical configurations and a wide range of chain size from 12.5 to 22mm.
- Vertical units have the Devil's Claw operating vertically, while horizontal units have the Devil's Claw operating horizontally.
- The height of chain operation is designated by windlass size. For example, it is possible to use a V8 size unit with a V9 windlass if the Devil's Claw is mounted on a plinth to raise it to the correct height.
- Custom options available. Contact [custom@lewmar.com](mailto:custom@lewmar.com) for more information.



#### Devil's Claw Horizontal

PART NO.	DESCRIPTION
69000506	16MM STUDLINK VERTICAL DCRS (V9)
69000515	16MM STUDLINK HORIZONTAL DCRS (V9 / V10 / V12)
69000504	17,5MM STUDLINK HORIZONTAL DCRS (V9 / V10 / V12)
69000510	19MM STUDLINK HORIZONTAL DCRS (V10 / V12)
69000509	22MM HORIZONTAL DCRS (V12)

#### Devil's Claw Vertical

PART NO.	DESCRIPTION
69000499	12.5MM STUDLINK VERTICAL DCRS (V8)
69000412	14MM SHORTLINK VERTICAL DCRS (V8)
69000507	14MM STUDLINK VERTICAL DCRS (V8)
69000508	14MM STUDLINK VERTICAL DCRS (V9)
69000500	16MM STUDLINK VERTICAL DCRS (V8)

### Anchor Safety Straps

- Lewmar recommends securing the anchor to the boat when not in use
- Prevents the anchor from deploying unintentionally
- Simply clipped on the chain, shackle, or anchor
- The windlass is not designed to hold the anchor to the boat when not in use

PART NUMBER (NON PVC COATED)	DESCRIPTION	SAFE WORKING LOAD	
		KG	LB
66840027	ANCHOR SAFETY STRAP 3MM WIRE	70	154
66840028	ANCHOR SAFETY STRAP 4MM WIRE	140	309

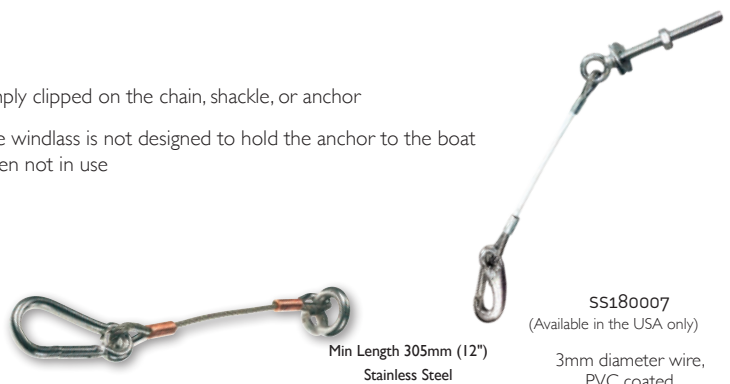



### Standard Chain Stoppers

- A stylish range of cast stainless chain stoppers
- Made from 316 stainless steel
- Windlasses are not designed to hold high loads while a boat is at anchor
- When the windlass is not in use and the boat is at anchor, the chain should be secured using a chain stopper, or the rope rode should be attached to a load-bearing point such as a cleat
- Perfect for sleep-filled nights and lazy lunches



66840079

### Dimensions Diagram

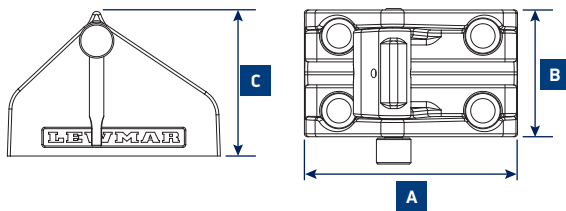

### Chain Stoppers with Claw



### Chain Stopper Specifications

PART NUMBER	CHAIN SIZE		A		B		C	
	MM	IN	MM	IN	MM	IN	MM	IN
66840077	8	5/16	110	4 5/16	65	2 1/2	79	3 1/8
66840079	10	3/8	110	4 5/16	65	2 1/2	79	3 1/8
66840080	12-13	1/2	148	5 7/8	88	3 1/2	101	4
66840081	13-14	9/16	160	6 5/16	100	3 15/16	106	4 3/16
66840083	16	5/8	184	7 1/4	116	4 9/16	122	4 13/16
66840069 <sup>1</sup>	6-10	1/4-3/8	79	3 1/8	60	2 3/8	57	2 1/4

<sup>1</sup>STAINLESS STEEL DELUXE ANCHOR SAFETY DEVICE (USA ONLY)

PART NUMBER	CHAIN SIZE		A		B		C	
	MM	IN	MM	IN	MM	IN	MM	IN
69000608	8	5/16	110	4.3	65	2.5	95	3.75
69000609	10	3/8	110	4.3	65	2.5	95	3.75
69000610	12	1/2	148	5.8	88	3.5	124	4.8

### Swivels

- Heavy-duty anchor rode swivel
- Attach between line and chain or between chain and anchor
- Material: 316 Stainless Steel
- Stainless steel screw pins



PART NUMBER	DESCRIPTION
66840329	ANCHOR SWIVEL (8MM CHAIN)
66840078	ANCHOR SWIVEL (10MM CHAIN)
66840082	ANCHOR SWIVEL (12MM CHAIN)
65003097	ANCHOR SWIVEL (14MM CHAIN)
66840111	ANCHOR SWIVEL (16MM CHAIN)
SWIVEL6*	ANCHOR SWIVEL (6MM CHAIN)
SWIVEL312F*	ANCHOR SWIVEL (FIXED 1/4" & 5/16" CHAIN)
SWIVEL500F*	ANCHOR SWIVEL (FIXED 3/8", 1/2, 7/16" CHAIN)

\*USA ONLY

# 2. Anchoring

## Anchor Accessories

### Anchor Rodes

- Designed to complement the rope-chain gypsies fitted to all Lewmar windlasses
- Calibrated for even pitch
- Hot dip galvanised to minimise corrosion
- Welded for high strength
- Smooth rope-to-chain transition
- Helps your windlass operate smoothly
- Hand-sewn whipping guarantees against unravelling



### Premium 3 Strand Rodes (USA only)

PART NUMBER	DESCRIPTION
69000331	5 1/4 G4 X 100 1/2 WITH 5/16 SHACKLE
69000332	10 1/4 G4 X 150 1/2 WITH 5/16 SHACKLE
69000334	15 1/4 G4 X 200 1/2 WITH 5/16 SHACKLE
69000335	15 1/4 G4 X 300 1/2 WITH 5/16 SHACKLE
69000339	20 5/16 G4 X 200 9/16 WITH 3/8 SHACKLE

### Premium 8 Plait Rodes (USA only)

PART NUMBER	DESCRIPTION
HM10HT200PX	10 1/4 G4 - 200 1/2 8PLT WITH SHACKLE
HM15HT300PX	15 1/4 G4 - 300 1/2 8PLT WITH SHACKLE
HM15H300PX	15 5/16 G4 - 300 5/8 8PLT WITH SHACKLE

### Bow Rollers

- Friction-free surface to make dropping and retrieving anchor easier
- Will not damage the deck or topsides
- Allows you to safely stow anchor while cruising and deploy at short notice
- Constructed of 304 stainless steel
- Range of rollers to fit the most common combinations of anchor; mounting style and boat



### Dimension Diagram

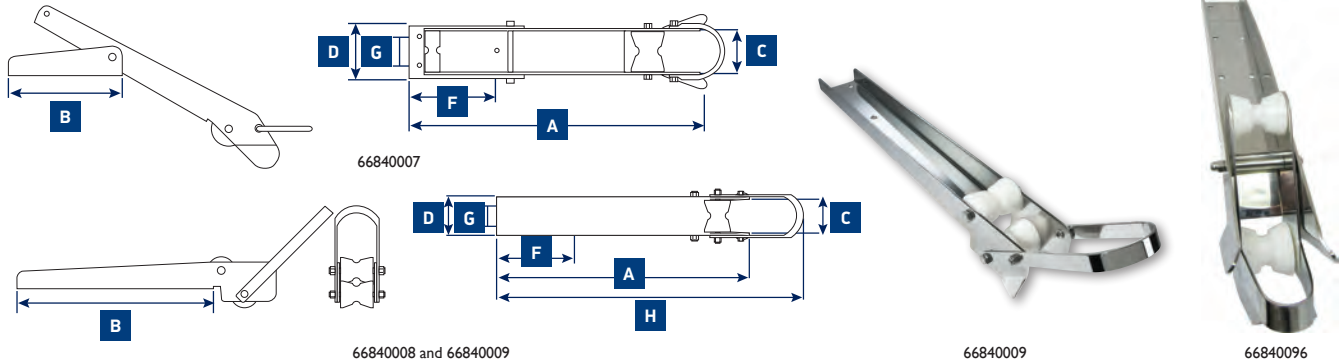

### Bow Rollers Specification

PART NUMBER	WEIGHT		ANCHOR TYPE	A		B		C		D		F		G		H	
	KG	LB		MM	IN	MM	IN	MM	IN	MM	IN	MM	IN	MM	IN	MM	IN
66840007	3.6	8	ANY FLUKE STYLE TO 35LB/16KG	524	20	103	8	76	3	99	3 7/8	153	6	51	2	-	-
66840008	4	9	14, 22 @ 35LB (7, 10 @ 16KG) DELTA® AND DTX ANCHORS	495	19 1/2	376	14 13/16	67	2 5/8	80	3 1/8	153	6	38	1 1/2	602	23 11/16
66840009	4.5	10	14, 22 @ 35LB (7, 10 @ 16KG) DELTA® AND DTX ANCHORS	597	23 1/2	478	18 13/16	67	2 5/8	80	3 1/8	153	6	38	1 1/2	704	27 11/16
66840060	0.5	1	SMALL BOW ROLLER	-	-	102	4	51	2	-	-	-	-	-	-	159	6 1/4
66840085	5	11	22, 35 @ 45LB (10, 16 @ 20KG) DELTA® AND DTX ANCHORS	-	-	400	15 3/4	77	3	80	3 1/7	242	9 1/2	46	1 13/16	577	22 11/16
66840096	8.2	18	35-55DTX/DELTA PIVOTING R1	-	-	510	20 1/16	113	4 7/16	123	4 7/8	466	18 5/16	47	1 6/7	730	28 3/4



### 3. Thruster

Manoeuvring around the dock area can be difficult, but Lewmar's Thrusters make docking simple. The revolutionary design of the Lewmar propeller – the latest in Lewmar's long history of custom thruster solutions – achieves even thrust in both directions for maximum control and manoeuvrability.

All Lewmar Thrusters have been extensively tested, resulting in a smooth, efficient and quiet performance that will have you docking like a pro in no time.

## 3. Thrusters

### The Lewmar Thruster Range



#### Page 104 TT Electric Thruster

- Available from 1.5kW to 15kW (20HP)
- High performance 5-blade propellers give equal thrust in both directions
- No reservoir to install, no leaks, and low maintenance
- Complete range of TT Electric Thruster accessories available



#### Page 110 Retracting Thruster

- Electronic box with waterproof connectors
- Strong actuator with safety shear pin for rapid deployment
- Unique 'low-pivot' mechanism enables deeper immersion while inhabiting a smaller space
- Customised boat-specific flange versions available for volume requirement
- Dual propellers on 185 & 250 models as standard



#### Page 112 Lewmar Proportional Thrusters

- Limitless running - the only restriction is your battery capacity
- Ultimate control - proportional throttling allows delicate manoeuvring
- Zero maintenance - longer life without a need for servicing.
- Retro-fit kits compatible with existing thrusters



#### Page 116 TT Hydraulic Thruster

- Enables significant flexibility of vessel movement
- Increased thrust over equivalent DC Electric version
- 250 and 300 models available with bronze or aluminium hub



#### Page 118 Custom Thrusters

- Unique Swing and Vertical Retracting Hydraulic Thruster offers a completely fair hull section
- Available with bronze or aluminium legs



#### Page 120 Accessories and Spares

- Thruster Tunnels
- Stern Kits
- Support brackets
- Anodes
- Propellers

## How to choose the right thruster for your boat

The boat's wind area, the 'lateral wind draft area', and the thruster's tunnel position in the hull determine the thruster's performance on a boat. By knowing these factors we can calculate the wind pressure on the boat and the centre point of this wind pressure. From these calculations we can determine what thrust is needed to counter the wind pressure with the given thruster position. To gain total control of your boat, install both a bow and stern thruster, leaving the main engines to propel the boat forward and backward.

The main factors that decide correct thruster sizing are:

### 1 Position of the thruster

The actual position of the thruster will depend on the internal & external construction of the vessel.

For optimal performance the thruster should be mounted within the following parameters:

- As far forward as possible to maximise the lever effect. (Fig 1)
- $1 \times \varnothing$  (0.75  $\times$   $\varnothing$  minimum) below the waterline to prevent air being sucked into the tunnel. (Fig. 2).  $\varnothing$ =Tunnel Diameter.
- Minimum suggested tunnel length  $2 \times \varnothing$ .

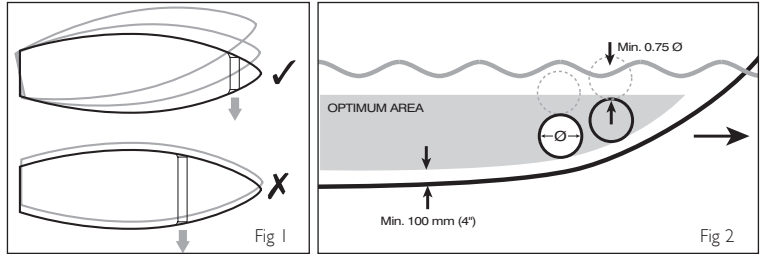

### 2 Boat size, type and shape



Light displacement / low windage

Light control / light displacement



Medium displacement / Medium windage

Medium control / medium displacement

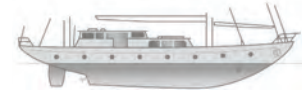

Heavy displacement / High windage

High control / Heavy boat

### Boat length overall

	M FT	9 M 30 FT	11 M 35 FT	12 M 40 FT	14 M 45 FT	21 M 50 FT	17 M 55 FT	18 M 60 FT	20 M 65 FT	21 M 70 FT	23 M 75 FT	24 M 80 FT	26 M 85 FT	27 M 90 FT
110TT 1.5														
125TT 2.0														
140TT 2.0														
140TT 2.2														
185TT 3.0														
185TT 4.0														
185TT 5.0														
185TT 6.0														
250TT 8.0														
300TT 10.8 250TT HVD														
300TT 15.0														
300TT HVD														

### Vertical Retracting and Swing Thrusters Size Guide

	10 M 35 FT	12 M 40 FT	15 M 50 FT	18 M 60 FT	21 M 70 FT	24 M 80 FT	27 M 90 FT	30 M 100 FT	33 M 110 FT	36 M 120 FT	39 M 130 FT	42 M 140 FT	45 M 150 FT	48 M 160 FT
250 20HP														
300 30HP														
400 60HP														
500 80HP														
600 100HP														

### 3. Thrusters

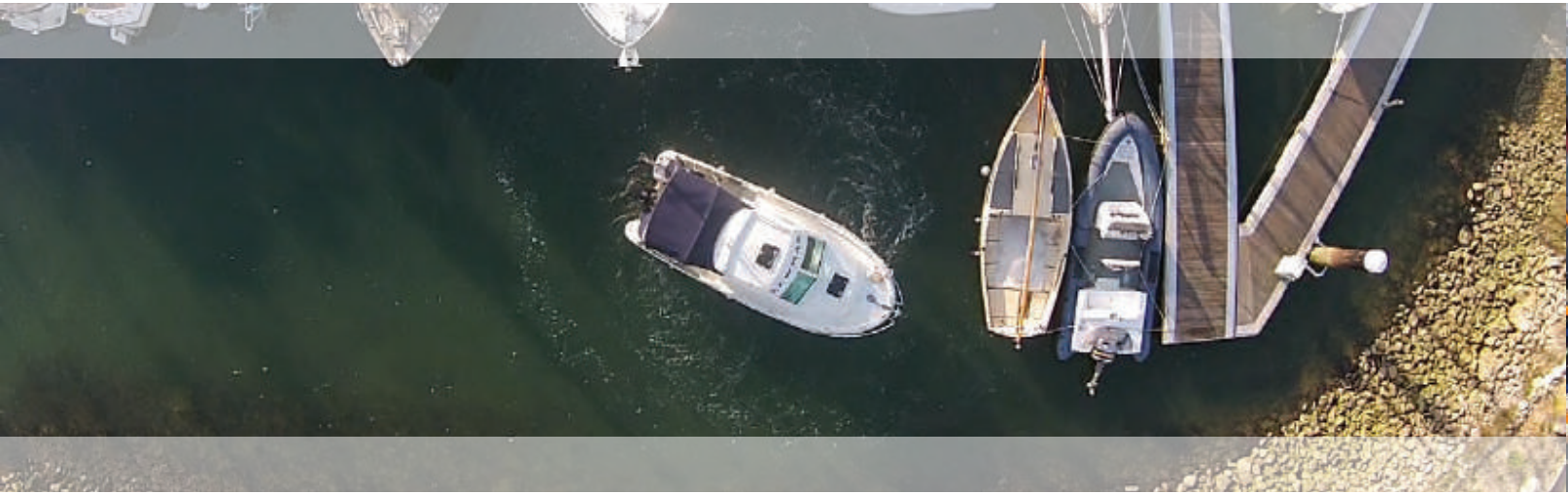

### Lewmar TT Thrusters

Great care and attention to detail goes into the design and manufacture of every Lewmar thruster. High performance, ease-of-use and reliability are our priorities. In order to achieve that, every thruster we make includes the features below.

Custom-made to Lewmar specifications, the motors are highly reliable and high performance. Replacement brushes are available.

Easy, plug-together switch connections

Lewmar cassette seal gives excellent protection and better sealing than standard lip seal. This enables Lewmar TT thrusters to be installed without the need for a top-up reservoir and its associated maintenance.

Hardened and ground spiral bevel gears for maximum efficiency and quiet power transmission

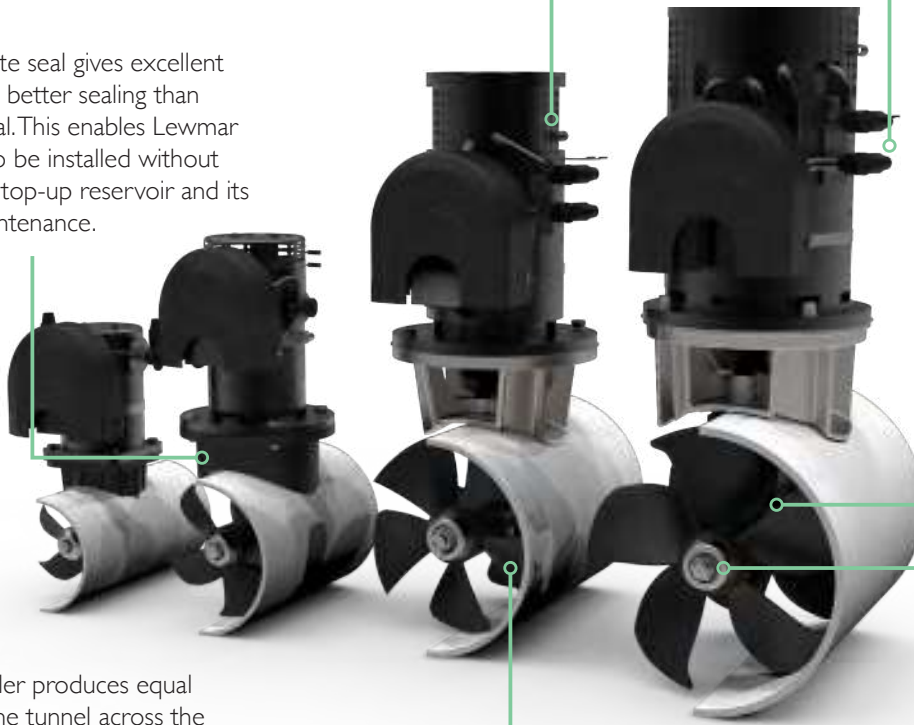

5-blade propeller produces equal thrust out of the tunnel across the full 110-185 range from a single propeller. The 250 & 300 utilise twin counter rotating props to get the best performance from larger tunnels and higher power outputs.

The Lewmar TT anode has a specially designed stainless steel sheath for optimal retention. Secured with a large nut, it is simple to replace.





## Small Boat TT Electric Thruster

The I10TT, I25TT and I40TT 2.0kW are also available without a blue box ICU. The simplified system provides a flexible and easy installation solution, without compromising on performance.

Simple System on its own



### I10TT, I25TT and I40TT 2.0 kW Thruster Specifications

PART NO	DESCRIPTION	TUNNEL SIZE (MM)	POWER		MOTOR VOLTAGE	GEARBOX MATERIAL	PROPELLER	THRUST		WEIGHT		CURRENT DRAW AMPS	FUSE		FUSE HOLDER	
			KW	HP				KG	LBS	KG	LBS		RATING	PART NUMBER	T1 - 589006	T2 - 589013
591101	TT 110 1.5KW 12V	110	1.5	2.0	12V	COMPOSITE	SINGLE 5 BLADE	28	62	10	22	230	200A	589012	√	√
591251	TT 125 2.0KW 12V	125	2.0	2.7	12V	COMPOSITE	SINGLE 5 BLADE	35	77	12	26	-	-	-	-	-
591482	TT 140 2.0KW 12V	140	2.0	2.7	12V	COMPOSITE	SINGLE 5 BLADE	37	82	13	29	270	200A	589012	√	√

### I10TT, I25TT and I40TT 2.0 kW Simple Joystick

- Ideal entry level control of thrusters
- Features On/Off illumination
- Easy installation connection
- Auto-Shut off not available
- For use with 591101 and 591482 only



589094

### Simple Joystick Connecting Leads and Y Connectors

- Simply measure the distance from the thruster to the panel to choose the suitable lead
- For connecting an additional panel, order an extra control loom for the distance to the extra panel
- If you are installing a second or third panel, use a Y Connector to divert power back to the thruster
- Not compatible with GEN 2 systems

### Cable Specifications

4-WIRE CABLE	LENGTH
589021	2M
589016	7M
589017	10M
589018	14M
589019	18M
589206	'Y' CONNECTOR

# 3. Thrusters



## GEN 2 TT Electric Thruster

### TT Thruster Specifications

PART NO		DESCRIPTION	TUNNEL SIZE		POWER		MOTOR VOLTAGE	GEARBOX MATERIAL	PROPELLER	THRUST		WEIGHT		FUSE		FUSE HOLDER	
STANDARD	IP RATED		(MM)	(MM)	KW	HP				KG	LBS	KG	LBS	RATING	PART NUMBER	T1 - 589006	T2 - 589013
590000	590001	TT 110 12V	110	1.5	2.0	12V	COMPOSITE	SINGLE 5 BLADE	28	62	10	22	200A	589012	✓	✓	
590101	590102	TT 125 2.0KW 12V	125	2.0	2.7	12V	COMPOSITE	SINGLE 5 BLADE	35	77	12	26	-	-	-	-	
590002	590004	TT 140 2.0KW 12V	140	2.0	2.7	12V	COMPOSITE	SINGLE 5 BLADE	37	82	13	29	200A	589012	✓	✓	
590003	590005	TT 140 2.2KW 12V	140	2.2	3.0	12V	COMPOSITE	SINGLE 5 BLADE	42	93	13	29	200A	589012	✓	✓	
590006	590014	TT 185 3.0KW 12V	185	3.0	4.0	12V	ST/ST	SINGLE 5 BLADE	58	128	20	43	250	589008	✓	✓	
590007	590015	TT 185 3.0KW 24V	185	3.0	4.0	24V	ST/ST	SINGLE 5 BLADE	58	128	20	43	130A	589007	✓	✓	
590008	590016	TT 185 4.0KW 12V	185	4.0	5.4	12V	ST/ST	SINGLE 5 BLADE	65	143	20	43	400A	589010		✓	
590009	590017	TT 185 4.0KW 24V	185	4.0	5.4	24V	ST/ST	SINGLE 5 BLADE	65	143	20	43	130A	589007	✓	✓w	
590010	590018	TT 185 5.0KW 12V	185	5.0	6.7	12V	ST/ST	SINGLE 5 BLADE	82	181	27	59	400A	589010		✓	
590011	590019	TT 185 5.0KW 24V	185	5.0	6.7	24V	ST/ST	SINGLE 5 BLADE	82	181	27	59	130A	589007	✓	✓	
590012	590020	TT 185 6.0KW 12V	185	6.0	8.0	12V	ST/ST	SINGLE 5 BLADE	97	214	27	59	500A	589011		✓	
590013	590021	TT 185 6.0KW 24V	185	6.0	8.0	24V	ST/ST	SINGLE 5 BLADE	97	214	27	59	325A	589009	✓	✓	
590022		TT 250 8.0KW 24V AL	250	8.0	10.8	24V	ALUMINIUM	TWIN CR 5 BLADE	140	308	46	206	400A	589010		✓	
590024		TT 250 8.0KW 24V	250	8.0	10.8	24V	BRONZE	TWIN CR 5 BLADE	140	308	46	206	400A	589010		✓	
590030		TT 300 10.8KW 24V AL	300	10.8	14.5	24V	ALUMINIUM	TWIN CR 5 BLADE	250	550	65	143	500A	589011		✓	
590031		TT 300 15.0KW 48V AL	300	15.0	20.0	24V	ALUMINIUM	TWIN CR 5 BLADE	280	616	68	150	400A	589010		✓	
590032		TT 300 17.0KW 48V AL	300	17.0	22.7	48V	ALUMINIUM	TWIN CR 5 BLADE	235				400A	589011		✓	
590033		TT 300 10.8KW 24V	300	10.8	14.5	24V	BRONZE	TWIN CR 5 BLADE	250	550	65	143	500A	589011		✓	
590034		TT 300 15.0KW 48V	300	15.0	20.0	24V	BRONZE	TWIN CR 5 BLADE	280	616	38	150	400A	589011		✓	
590035		TT 300 17.0KW 48V	300	17.0	22.7	48V	BRONZE	TWIN CR 5 BLADE	235	518	87	192	400A	589011		✓	

CR = COUNTER ROTATING

### TT Dimensions

MODEL	A		B		C		D	
	MM	IN	MM	IN	MM	IN	MM	IN
110TT 1.5	123	4 5/8	208	8 3/16	110	4 1/3	64	2 1/2
125TT 2.0	123	4 5/8	209	8 1/4	125	5	71	2 1/2
140TT 2.0	123	4 5/8	213	8 3/8	140	5 1/2	71	2 13/16
140TT 2.2	123	4 5/8	235	9 1/4	140	5 1/2	71	2 13/16
185TT 3.0 / 185TT 4.0	148	5 7/8	293	11 1/2	185	7 5/16	83	3 1/4
185TT 5.0	162	6 3/8	315	12 3/8	185	7 5/16	83	3 1/4
185TT 6.0	161	6 3/8	343	13 1/2	185	7 5/16	83	3 1/4
185TT 6.0	161	6 3/8	343	13 1/2	185	7 5/16	83	3 1/4
250TT 8.0	165	6 1/2	422	16 5/8	250	9 13/16	256	10 1/16
300TT 10.8 / 300TT 15	203	8	450	17 11/16	300	11 13/16	320	12 7/8

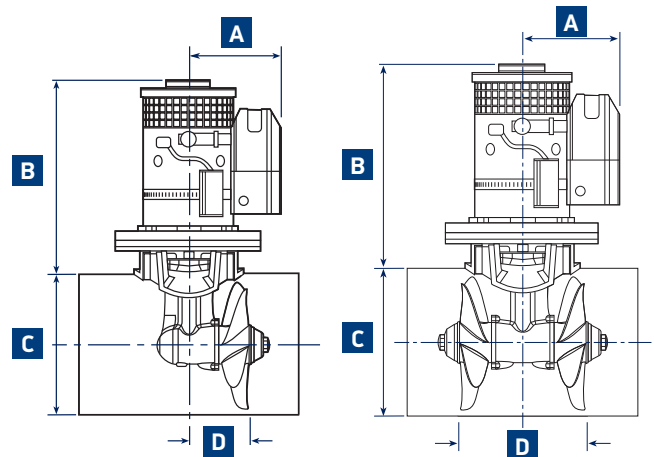

110TT, 140TT & 185TT

250TT & 300TT



### IP Thruster Dimensions

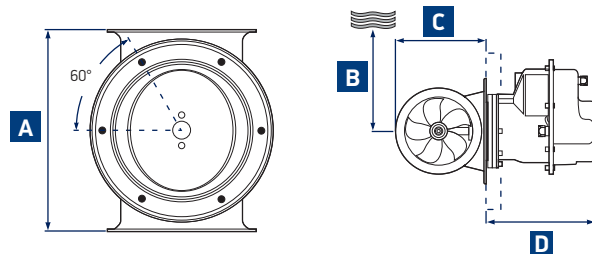

MODEL	A		B		C		D	
	MM	IN	MM	IN	MM	IN	MM	IN
140 IP THRUSTER	225	8 7/8	210	8 1/4	190	7 1/2	273	10 3/4
185 IP THRUSTER	320	12 5/8	278	10 15/16	248	9 3/4	298	11 3/4

### Blue Box Systems

The Lewmar blue box system is the new design of ICU in our next-generation thruster system. The main electronic components of the system have been completely redesigned to increase reliability and functionality.

The configuration has been designed to be as simple and reliable as possible while incorporating today's technological trends. The blue box system is used on all Gen 2 thrusters from 110 to 300TT.



- Health-check LED and on-board fuse
- Powers and provides logic for panel controller
- Phoenix contact for power and neutral
- One ICU per thruster
- Compatible with ABS and power switches

PART NUMBER	DESCRIPTION
589274	TT THRUSTER ICU
589296	RT THRUSTER ICU

### 3. Thrusters



#### Thruster Control Panels

Lewmar's new range of thruster control panels provide superior tactile control of single or dual thruster installations.

The panels are designed for all Lewmar TT, RT, SRT & VRT thrusters fitted with a blue box and can be fitted to thrusters fitted with a black-box using a controller adaptor.

The control panels are installed without the need for rear access and feature a snap-on bezel to neatly hide the mounting screws. A cover (Pad only) is also included, providing additional security against accidental use and giving extra environmental protection. If replacing a previous generation touch panel, joystick panel or dual joystick panel, the existing mounting hole can be reused.

- Ergonomic control 'pad' gives tactile feedback
- Membrane switch panel sealed from dust and moisture ingress
- Single and dual controllers available
- Dual controllers give total control of vessel via multi-axis function pad
- 12-24V dual voltage supply
- Multi-function LED indicator displays system deployment, thruster operation, low voltage, motor temperature warnings & fault conditions.
- Upgrade kit allows installation of single or dual controllers into a thruster system with previous generation controllers
- Fit existing cut-out of Lewmar joysticks
- Removable cover on pad controllers





PART NUMBER	DESCRIPTION
589268	SINGLE JOYSTICK
589223	SINGLE PAD
589267	DUAL JOYSTICK
589222	DUAL PAD



### Single/Dual Controller Connecting Leads and Splitter

- Simply measure the distance from the Thruster to the Panel to choose the suitable lead
- If you are installing a second or third panel, use a Y Connector to divert power back to the Thruster
- Y connectors can only be used with like for like panels (Dual with dual / Single with single)

Y LOOM MX	AUX LOOM MX	LENGTH
589800	589801	2M
	589802	7M
	589803	10M
	589804	18M
	589805	22M



### 3. Thrusters



#### Lewmar Retractable Thrusters

Lewmar's range of retractable thrusters have been developed in conjunction with boat owners and their needs. Particular care and attention to the detail of the installation process was taken into consideration while retaining the proven components from the Lewmar TT thruster range. Lewmar thrusters achieve even thrust in both directions for maximum control and manoeuvrability. All Lewmar thrusters have been extensively tested, resulting in a smooth, efficient and reliable operation.

- The patented 'low pivot' mechanism minimises internal space requirements yet permits maximum tunnel immersion
- Flange mounting as standard for easy installation. The universal flange can be adjusted to any given hull shape
- Robust GRP construction
- 140, 185 and 250mm tunnel diameters available
- Auto-retract function after 5 minutes of non-use
- Dual propellers on 185 & 250 models as standard





### RT Thruster Dimensions

THRUSTER	A		B		C		D		E	
	MM	IN	MM	IN	MM	IN	MM	IN	MM	IN
140TT 2.0KW 12V	196	7 23/32	315	12 13/32	612	24 3/32	207	8 5/32	310	12 13/64
140TT 2.2KW 12V	196	7 23/32	315	12 13/32	612	24 3/32	207	8 5/32	310	12 13/64
185TT 4.0KW 12V	220	8 21/32	360	14 11/64	690	27 11/64	242	9 17/32	346	13 5/8
185TT 4.0KW 24V	220	8 21/32	360	14 11/64	690	27 11/64	242	9 17/32	346	13 5/8
185TT 5.0KW 12V	220	8 21/32	385	15 5/32	690	27 11/64	242	9 17/32	346	13 5/8
185TT 5.0KW 24V	220	8 21/32	385	15 5/32	710	27 61/64	242	9 17/32	346	13 5/8
185TT 6.0KW 12V	220	8 21/32	410	16 9/64	710	27 61/64	242	9 17/32	346	13 5/8
185TT 6.0KW 24V	220	8 21/32	410	16 9/64	730	27 61/64	242	9 17/32	346	13 5/8
185TT 7.0KW HYD	220	8 21/32	250	9 27/32	730	27 61/64	242	9 17/32	346	13 5/8
250TT 8.0KW 12V	303	11 59/64	505	19 7/8	940	37 1/64	306	12 3/64	468	18 27/64
250TT 15.0KW HYD	303	11 59/64	310	12 13/64	810	31 57/64	306	12 3/64	468	18 27/64

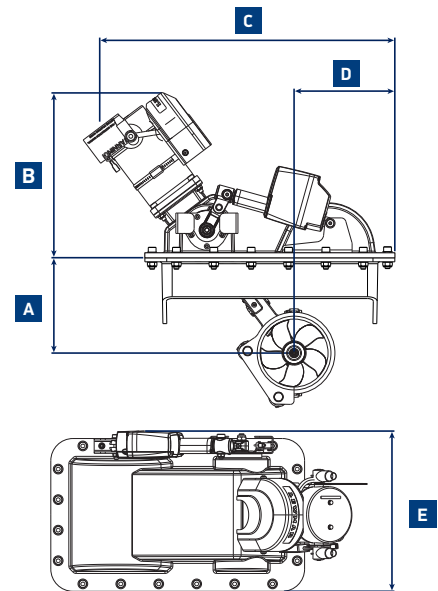

PART NUMBER	IP PART NUMBER	DESCRIPTION	TUNNEL SIZE	ACTUATOR		POWER		MOTOR			POWER SWITCH	GEARBOX MATERIAL	PROPELLER	THRUST		WEIGHT		FUSE		FUSE HOLDER	
				12V	24V	KW	HP	12V	24V	HYD				12 TO 24	KGf	LBS	KG	LBS	RATING	PART NUMBER	T1 - 589006
59111001	59111003	RT140 2.0KW 12V	140	✓		2.0	2.7	✓				COMPOSITE	SINGLE 5 BLADE	37	82	29.2	65	200A	589012	✓	✓
59111002	59111004	RT140 2.2KW 12V	140	✓		2.2	3.0	✓				COMPOSITE	SINGLE 5 BLADE	42	93	29.2	65	200A	589012	✓	✓
59112004	59112019	RT185 4.0KW 12V	185	✓		4.0	5.4	✓				BRASS	DUAL 5 BLADE	65	143	44.8	99	400A	589010		✓
59112005	59112020	RT185 4.0KW 24V/12V	185	✓		4.0	5.4	✓		✓		BRASS	DUAL 5 BLADE	65	143	43	95	130A	589007		✓
59112006	59112021	RT185 4.0KW 24V	185		✓	4.0	5.4	✓				BRASS	DUAL 5 BLADE	65	143	43	95	130A	589007		✓
59112007	59112022	RT185 5.0KW 12V	185	✓		5.0	6.7	✓				BRASS	DUAL 5 BLADE	82	181	53.4	118	400A	589010		✓
59112008	59112023	RT185 5.0KW 24V/12V	185	✓		5.0	6.7	✓		✓		BRASS	DUAL 5 BLADE	82	181	51.4	114	130A	589007	✓	✓
59112009	59112024	RT185 5.0KW 24V	185		✓	5.0	6.7	✓				BRASS	DUAL 5 BLADE	82	181	51.4	114	130A	589007	✓	✓
59112010	59112025	RT185 6.0KW 12V	185	✓		6.0	8.0	✓				BRASS	DUAL 5 BLADE	97	214	53	117	500A	589011		✓
59112011	59112026	RT185 6.0KW 24V/12V	185	✓		6.0	8.0	✓		✓		BRASS	DUAL 5 BLADE	97	214	51.5	114	325A	589009	✓	✓
59112012	59112027	RT185 6.0KW 24V	185		✓	6.0	8.0	✓				BRASS	DUAL 5 BLADE	97	214	51.5	114	325A	589009	✓	✓
59112013		RT185 HYD 12V	185	✓		7.0	10.0		✓			BRASS	DUAL 5 BLADE	100	220	33	73				
59112014		RT185 HYD 24V	185		✓	7.0	10.0		✓			BRASS	DUAL 5 BLADE	100	220	33	73				
59113001		RT250 8.0KW 24V/12V	250	✓		8.0	10.8	✓		✓		BRONZE	TWIN CR 5 BLADE	140	308	107	236	400A	589010		✓
59113002		RT250 8.0KW 24V	250		✓	8.0	10.8	✓				BRONZE	TWIN CR 5 BLADE	140	308	107	236	400A	589010		✓
59113005		RT250 HYD 12V	250	✓		15.0	20.0		✓			BRONZE	TWIN CR 5 BLADE	200	440	74	163				
59113006		RT250 HYD 24V	250		✓	15.0	20.0		✓			BRONZE	TWIN CR 5 BLADE	200	440	74	163				

### 3. Thrusters



#### Lewmar Proportional Thrusters

The new Proportional thrusters from Lewmar have unlimited run-time, are very quiet in use, maintenance free and suitable for 24V installation. The proportional series can be controlled by one of the four new proportional control panels developed for this new type of motor:

The proportional thrusters motor is a nearly silent motor and has unlimited runtime. The induction motor is controlled by the Lewmar Curtis controller. This in-house engineered motor controller can control 24V inputs. With this new system, Brushless motors have been chosen for their efficiency and unlimited runtime, and their ability to withstand tough sailing.

Retrofitting the Lewmar proportional series is also very easy. The proportional thrusters are backwards compatible to replace existing Lewmar bow thruster installations.

- Limitless running - the only restriction is your battery capacity
- Ultimate control - proportional throttling allows delicate maneuvering
- Zero maintenance - longer life without a need for servicing.
- Retro-fit kits compatible with existing thrusters







### Proportional Thrusters Kits

PART NO	DESCRIPTION	TUNNEL SIZE	POWER	SHEAR PIN	AMPS	KGf
24V		(MM)	KW		CURRENT DRAW	THRUST @ 100% THROTTLE KGf
59092000	140 TT 2.2 KW PROPORTIONAL	140	2.2	ST/ST	100	21
59092001	140 TT 2.2 KW PROPORTIONAL BRASS	140	2.2	ST/ST	100	21
59093000	185 TT 3.0KW PROPORTIONAL ST/ST	185	3.0	ST/ST	150	45
59093001	185 TT 3.0KW PROPORTIONAL ALLOY	185	3.0	ST/ST	150	45
59093002	185 TT 4.0KW PROPORTIONAL ST/ST	185	4.0	ST/ST	180	60
59093003	185 TT 4.0KW PROPORTIONAL ALLOY	185	4.0	ST/ST	180	60
59093004	186 TT 5.0KW PROPORTIONAL ST/ST	185	5.0	ST/ST	215	67
59093005	186 TT 5.0KW PROPORTIONAL ALLOY	185	5.0	ST/ST	215	67
59093006	186 TT 6.0KW PROPORTIONAL ST/ST	185	6.0	ST/ST	240	76
59093007	186 TT 6.0KW PROPORTIONAL ALLOY	185	6.0	ST/ST	240	76
59094001	250 TT 8.0KW 24V PROPORTIONAL	250	8.0	ST/ST	360	119

### Retro Fit Proportional Motor Kits

PART NO	DESCRIPTION	TUNNEL SIZE	POWER	MOTOR VOLTAGE	SHEAR PIN	AMPS	KGf
24V		(MM)	KW			CURRENT DRAW	THRUST @ 100% THROTTLE KGf
59092003	140 TT 2.2KW PROPORTIONAL RETRO KIT	140	2.2	24	ST/ST	100	21
59092004	140 TT 2.0KW PROPORTIONAL BRASS RETRO KIT	140	2.2	24	ST/ST	100	21
59093020	185 TT 3.0KW PROPORTIONAL ST/ST RETRO KIT	185	3.0	24	ST/ST	150	45
59093021	185 TT 3.0KW PROPORTIONAL ALLOY RETRO KIT	185	3.0	24	ST/ST	150	45
59093022	185 TT 4.0KW PROPORTIONAL ST/ST RETRO KIT	185	4.0	24	ST/ST	180	60
59093023	185 TT 4.0KW PROPORTIONAL ALLOY RETRO KIT	185	4.0	24	ST/ST	180	60
59093024	186 TT 5.0KW PROPORTIONAL ST/ST RETRO KIT	185	5.0	24	ST/ST	215	67
59093025	186 TT 5.0KW PROPORTIONAL ALLOY RETRO KIT	185	5.0	24	ST/ST	215	67
59093026	186 TT 6.0KW PROPORTIONAL ST/ST RETRO KIT	185	6.0	24	ST/ST	240	76
59093027	186 TT 6.0KW PROPORTIONAL ALLOY RETRO KIT	185	6.0	24	ST/ST	240	76
59094003	250 TT 8.0KW 24V PROPORTIONAL RETRO KIT	250	8.0	24	ST/ST	360	119

### Wiring Loom Kits

The proportional thruster systems and kits DO NOT include loom or control panel. For each install, we RECOMMEND selecting the length of the control panel loom carefully.

Control loom available in 7m, 10m, 14m, 18m, 22m.

PART NUMBER	DESCRIPTION
58090009	CONTROL PANEL LOOM - 7M
58090010	CONTROL PANEL LOOM - 10M
58090011	CONTROL PANEL LOOM - 14M
58090012	CONTROL PANEL LOOM - 18M
58090013	CONTROL PANEL LOOM - 22M
58090019	SPLITTER ASSY

### 3. Thrusters



#### Proportional Retracting Thrusters

The new proportional thrusters from Lewmar are also available for our Retracting thruster range. The proportional thrusters motor is a nearly silent motor and has unlimited runtime. The induction motor is controlled by the Lewmar Curtis controller. This in-house engineered motor controller can control 24V inputs.

Retrofitting the Lewmar proportional motor is also very easy. The proportional motor are backwards compatible to replace existing Lewmar retracting thrusters motors. The retrofit kits also include a pre-wired tunnel actuator:

- Flange mounting as standard for easy installation. The universal flange can be adjusted to any given hull shape and the captive nut allows effortless fastening from the top of the unit only
- Robust GRP construction
- 140, 185 and 250mm tunnel diameters available
- Auto-retract function after 5 minutes of non-use
- Dual propellers on 185 & 250 models as standard



PART NO	DESCRIPTION	TUNNEL SIZE	POWER	MOTOR VOLTAGE	SHEAR PIN	AMPS	KGf
24V		(MM)	KW			CURRENT DRAW	THRUST @ 100% THROTTLE KGf
59092002	140 RT 2.2KW PROPORTIONAL	140	2.2	24	ST/ST	110	18
59093010	185 RT 4.0KW PROPORTIONAL	185	4.0	24	ST/ST	190	50
59093011	185 RT 5.0KW PROPORTIONAL	185	5.0	24	ST/ST	220	60
59093012	185 RT 6.0KW PROPORTIONAL	185	6.0	24	ST/ST	250	72
59094002	250 RT 8.0KW 24V PROPORTIONAL	250	8.0	24	N/A	375	110

PART NO	DESCRIPTION	TUNNEL SIZE	POWER	MOTOR VOLTAGE	SHEAR PIN	AMPS	KGf
STANDARD		(MM)	KW			CURRENT DRAW	THRUST @ 100% THROTTLE KGf
59092005	140 RT 2.2KW PROPORTIONAL RETRO KIT	140	2.2	24	ST/ST	110	18
59093013	185 RT 4.0KW PROPORTIONAL RETRO KIT	185	4.0	24	ST/ST	190	50
59093014	185 RT 5.0KW PROPORTIONAL RETRO KIT	185	5.0	24	ST/ST	220	61
59093015	185 RT 6.0KW PROPORTIONAL RETRO KIT	185	6.0	24	ST/ST	250	72
59094004	250 RT 8.0KW 24V PROPORTIONAL RETRO KIT	250	8.0	24	N/A	375	110



## Proportional Control Thrusters

The combination of Lewmar's DC digital brushless motors and proportional control panels provide ultimate control over your boat.

Designed to mimic the experience of a hydraulic system, an adjustable throttle allows delicate and refined manoeuvring. Brushless motors have been chosen for their efficiency and extended runtime and their ability to withstand tough sea conditions. Lewmar's deep-rooted engineering experience gives you the ability to dock in the most difficult situations.

- Superior runtime over traditional brush motors
- Ultimate control - proportional throttling allows delicate manoeuvring
- Zero maintenance - with no brushes to replace, our new motors have a longer life without a need for servicing
- Control panels available in single and dual arrangements, with composite or high-quality aluminium bezel
- Compatible with existing thruster installations



PART NUMBER	DESCRIPTION
58090000	SINGLE, CONTROL PANEL
58090001	SINGLE ALLOY, CONTROL PANEL
58090002	DUAL, CONTROLER PANEL
58090003	DUAL ALLOY, CONTROL PANEL

### 3. Thrusters



### TT Hydraulic Thrusters

When longer duration is required or weight and space are critical, the hydraulic TT Thrusters are the ideal solution.

- Increased thrust in comparison to equivalent Electric TT Thruster
- Hydraulic thrusters typically powered by main engine or generator PTO pump
- Lewmar offers a custom tailored hydraulic solution
- 250TTH and 300TTH available with bronze or aluminium hub
- Proportional control available



#### TT Hydraulic Thruster Specifications

PART NO	MODEL	TUNNEL	PROPELLER	WEIGHT		POWER		THRUST KGF	GEARBOX	MOTOR SIZE CC/REV	FLOW L/MIN	PRESSURE BAR [DELTA]
				KG	LB	HP	KW					
591820	185TTH	185	SINGLE	8	17.6	10	7		BRONZE	6	25	210
591821	185TTH	185	SINGLE	8	17.6	10	7		BRONZE	5	21	250
592522	250TTH	250	TWIN CR	13	28.6	20	15	200	BRONZE	14	44	230
592521	250TTH	250	TWIN CR	13	28.6	20	15	200	BRONZE	17	53	190
592511	250TTH	250	TWIN CR	13	28.6	20	15	200	ALUMINIUM	17	53	190
592520	250TTH	250	TWIN CR	13	28.6	20	15	200	BRONZE	26	82	122
592510	250TTH	250	TWIN CR	13	28.6	20	15	200	ALUMINIUM	26	82	122
593023	300TTH	300	TWIN CR	17	37.4	30	22.5	300	BRONZE	19	52	290
593022	300TTH	300	TWIN CR	17	37.4	30	22.5	300	BRONZE	22	62	245
593021	300TTH	300	TWIN CR	17	37.4	30	22.5	300	BRONZE	26	72	210
593011	300TTH	300	TWIN CR	17	37.4	30	22.5	300	ALUMINIUM	26	72	210
593020	300TTH	300	TWIN CR	17	37.4	30	22.5	300	BRONZE	30	82	182
593010	300TTH	300	TWIN CR	17	37.4	30	22.5	300	ALUMINIUM	30	82	182

CR = COUNTER ROTATING

#### Dimensions

MODEL	A		B		C		D	
	MM	IN	MM	IN	MM	IN	MM	IN
185TTH	200	7 7/8	202	7 15/16	185	7 9/32	83	3 9/32
250TTH	258	10 5/32	227	8 15/16	250	9 27/32	257	10 1/8
300TTH	258	10 5/32	256	10 1/16	300	11 13/16	320	12 19/32

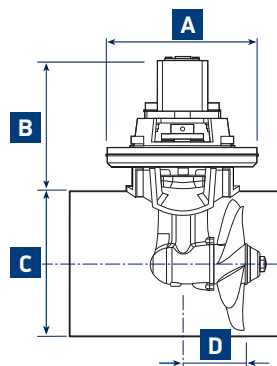

185TTH

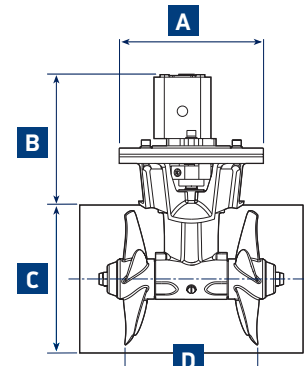

250/300TTH



## Hydraulic Thruster Control Panels

Lewmar's new range of thruster controls provides stylish and reliable control in all situations.

Our hydraulic controllers are designed to be integrated with a full hydraulic solution. They provide simple and dynamic control of Lewmar thruster units and offer a stylish alternative to the standard control panel range. Created to blend with the most advanced yacht consoles, Lewmar hydraulic controllers are robust, sensitive and striking.

- Single and dual controllers available
- Installed as part of a custom Lewmar hydraulic solution
- Stainless steel bezel provides strength and style

PART NUMBER	DESCRIPTION
589845	SINGLE JOYSTICK
589846	DUAL JOYSTICK



# 3. Thrusters

## Custom Thrusters

Manoeuvring larger vessels in the confines of a busy harbour or marina can challenge the most skilled crew. Cross winds and tides can be difficult to overcome with conventional propulsion and steering gear, particularly when mooring 'stern to'.

Lewmar Custom Thrusters can help provide additional control just when you need it, at the touch of a button or the move of a joystick. The Lewmar range of thrusters is suitable for sail or power vessels up to 164ft.

### Vertical Retracting Tunnel Thruster

- Suitable for vessels up to 164ft (50m)
- When not in use, the Thruster retracts into the hull leaving a clean line, so there is no drag
- The 300VRTT Hydraulic is capable of developing more than 30HP
- Bronze or Aluminium hub option
- Custom extended stroke available
- Better thruster immersion
- Can be mounted further forward
- Better performance per HP than standard tunnel Thruster
- Manual override
- 250/300VRTT 24V DC electric raise/lower



### Vertical Retracting Thruster Electric Specifications

PART NO	MODEL	TUNNEL	PROPELLER	WEIGHT		POWER		THRUST	GEARBOX	VOLTAGE
				KG	LB	HP	KW			
59127100	250VRTTE	250	TWIN CR	98	216	10.7	8	160	BRONZE	24VDC
59127110	250VRTTE	250	TWIN CR	102	224.9	13	9.6	170	BRONZE	48VDC

### Vertical Retracting Thruster Hydraulic Specifications

P/N	MODEL	TUNNEL	PROP	WEIGHT		POWER		THRUST	GEARBOX	MOTOR SIZE	FLOW	PRESSURE
				KG	LB	HP	KW					
59127002	250VRTTH	250	TWIN CR	65	143.3	20	15	200	BRONZE	26	82	122
59127004	250VRTTH	250	TWIN CR	65	143.3	20	15	200	BRONZE	17	53	190
59137001	300VRTTH	300	TWIN CR	75	165.3	30	22.5	300	ALUMINIUM	30	82	182
59137002	300VRTTH	300	TWIN CR	75	165.3	30	22.5	300	BRONZE	30	82	182
59137003	300VRTTH	300	TWIN CR	75	165.3	30	22.5	300	ALUMINIUM	26	72	210
59137004	300VRTTH	300	TWIN CR	75	165.3	30	22.5	300	BRONZE	26	72	210

400SVTH/ 500SVTH and 600SVTH available. Contact [custom@lewmar.com](mailto:custom@lewmar.com) for more information

### Dimensions

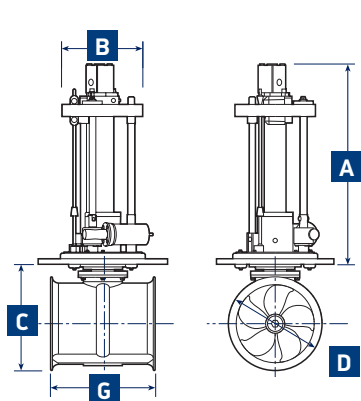

Shroud offset from CL

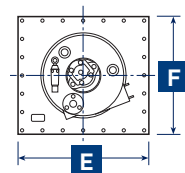

MODEL	A		B		C		D		E		F		G		STANDARD STROKE	
	MM	IN	MM	IN	MM	IN	MM	IN	MM	IN	MM	IN	MM	IN	MM	IN
250VRTTH	721	28 3/8	310	12 7/32	353	13 7/8	300	11 13/16	450	17 23/32	400	15 3/4	350	13 3/4	300	11 13/16
250VRTTE	911	35 7/8	310	12 7/32	353	13 7/8	300	11 13/16	450	17 23/32	400	15 3/4	350	13 3/4	300	11 13/16
300VRTTH	765	30 1/8	310	12 7/32	407	16	360	14 3/16	500	19 11/16	450	17 23/32	400	15 3/4	350	13 3/4
400SVTH	548	21 9/16	400	15 3/4	533	21	430	16 15/16	580	22 27/32	520	20 15/32	340	13 3/8	500	19 11/16
500SVTH	575	22 5/8	400	15 3/4	645	25 3/8	533	21	700	27 9/16	640	25 3/16	480	18 7/8	650	25 19/32
600SVTH	795	31 5/16	480	18 29/32	801	31 9/16	650	25 19/32	850	33 15/32	850	33 15/32	550	21 5/8	700	27 9/16

## Swing Retracting Hydraulic Thruster

- Ideal for higher performance sailing yachts, fast-planing or semi-displacement hulls
- Raised position offers a completely fair hull section causing minimum drag
- No hydraulic motors or hoses are immersed in the water
- Can be mounted further forward in the vessel without additional space intrusion into the forepeak
- Enhanced thrust performance from a lesser power input
- Better performance per HP than standard tunnel Thruster
- Bronze or Aluminium hub
- Manual override
- 500 series has an extended leg section that provides deeper thruster immersion
- 500 series can be mounted further forward than standard model, offering greater manoeuvrability

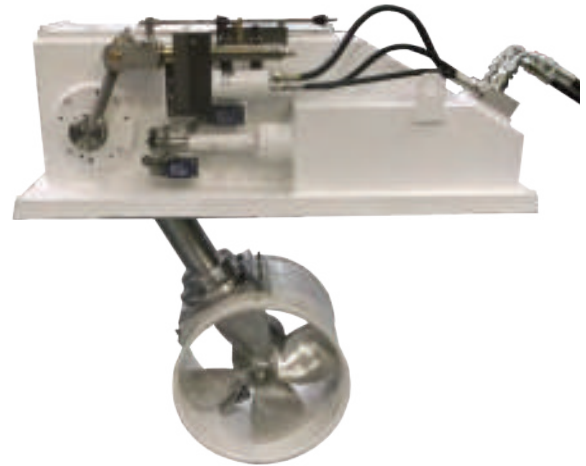

## Swing Retracting Hydraulic Thruster Selection Guide

PART NUMBER	MODEL	MATERIAL	POWER HP	TYPICAL VESSEL SIZE		THRUST
				M	FT	
51000370	400 S SWING RETRACTING HYDRAULIC THRUSTER SERIES	400 SAH	30-60	20-37	65-120	8-10 KG/KW (18-22 LBS/HP)
51000470	500 S SWING RETRACTING HYDRAULIC THRUSTER SERIES	500 SAH	65-75	25-43	80-140	8-10 KG/KW (18-22 LBS/HP)

Contact [custom@lewmar.com](mailto:custom@lewmar.com) for more information

## Dimensions

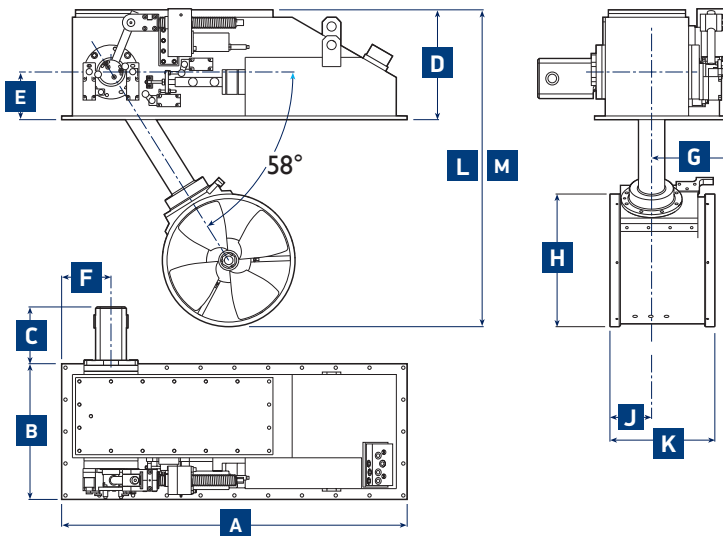

## Dimensions

MODEL	A		B		C		D		E		F		G		H		J		K		L		M	
	MM	INS	MM	INS	MM	INS	MM	INS	MM	INS	MM	INS	MM	INS	MM	INS	MM	INS	MM	INS	MM	INS	MM	INS
400 SWING 40HP	1120	44 1/8	440	17 5/16	184	7 1/4	390	15 3/8	154.5	6 3/32	160	6 5/16	255	10 1/32	430	16 15/16	135	5 5/16	340	13 3/8	603	23 3/4	1027	40 7/16
400 SWING 50HP	1120	44 1/8	440	17 5/16	190	7 15/32	390	15 3/8	154.5	6 3/32	160	6 5/16	255	10 1/32	430	16 15/16	135	5 5/16	340	13 3/8	603	23 3/4	1027	40 7/16
400 SWING 60HP	1120	44 1/8	440	17 5/16	196.5	7 3/4	390	15 3/8	154.5	6 3/32	160	6 5/16	255	10 1/32	430	16 15/16	135	5 5/16	340	13 3/8	603	23 3/4	1027	40 7/16
500 SWING	1255	49 1/2	590	23 1/4	116	4 9/16	438	17 1/4	154.5	6 3/32	160	6 5/16	250	9 27/32	545	21 15/32	285	11 1/32	480	18 29/32	680	26 3/4	1200	47 1/4

# 3. Thrusters

## Electric Thruster Accessories

### Black Box Controller Adaptor

Lewmar's range of thruster controllers provides reliable control of single or dual thruster installations.

The controllers can be fitted to all Lewmar TT thrusters fitted with a blue box and to the previous generation TT thrusters fitted with a black box using a controller converter.

- Upgrade kit allows the retrofit of the new generation controller with original black box systems
- Easy-fitting / Existing boat wiring can be used
- Needs to be installed next to the controller

PART NUMBER	DESCRIPTION
589865	SINGLE PAD
589864	DUAL PAD
589867	SINGLE JOY
589866	DUAL JOY



### Gen 2 Thruster Accessories

#### Single/Dual Controller Connecting Leads and Splitter

- Simply measure the distance from the Thruster to the Panel to choose the suitable lead
- If you are installing a second or third panel, use a Y Connector to divert power back to the Thruster
- Y only to be used on like for like panels (Single with single / Dual with dual)

#### Cable Specifications Gen 2

Y L00M MX	AUX L00M MX	LENGTH
589800	589801	2M
	589802	7M
	589803	10M
	589804	18M
	589805	22M

#### 589006 T1 Fuse Holder

- Designed for ANL fuses
- Comes complete with a polycarbonate safety cover



#### 589013 T2 Fuse Holder

- Higher specification fuse holder for ANL fuses
- Allows for easy fuse replacement
- Cable is clamped independently, so a fuse can be changed without disturbing the cable



#### Automatic Battery Switch

- Compatible with 140TT 2.2kW and above
- Easy to install
- Installed close to the batteries, it will prevent power from reaching the Thruster until the Panel is activated
- Manual override to disable system
- Automatically activates power when Panel is operated

PART NUMBER	DESCRIPTION
589810	GEN2 ABS 12V
589830	GEN2 ABS 24V
58090023	PROPORTIONAL ABS



#### Switch Box

- Enables safe usage of a 24V Thruster on a 12V boat
- Enables safe usage of 48V Thruster on a 24V boat
- Additional batteries required
- For suitability, see selection chart on next page

PART NUMBER	DESCRIPTION
589811	GEN2 PS 24/12V
589813	GEN2 PS 48/24V
559033	GEN2 PS 12/24V HD





Electric Tunnel Thruster Accessories and Spares

Accessories and Spares Selector

DESCRIPTION		110TT	125TT		140TT		185TT						250TT		300TT				
		591101 SIMPLE /590000 1.5 KW 12V	591251 SIMPLE /590002 2.0 KW 12V	590101 /590102 IP - 2.0 KW 12V	591482 SIMPLE /590002 590004 IP - 2.0 KW 12V	590003 /590005 IP - 2.2 KW 12V	590006 /590014 IP - 3.0 KW 12V	590007 /590015 IP - 3.0 KW 24V	590008 /590016 IP - 4.0 KW 12V	590009 /590017 IP - 4.0 KW 24V	590010 /590018 IP - 5.0 KW 12V	590011 /590019 IP - 5.0 KW 24V	590012 /590020 IP - 6.0 KW 12V	590013 /590021 IP - 6.0 KW 24V	590024 - 8.0 KW 24V	590022 - 8.0 KW 24V	590034 - 10.8 KW 24V	590035 - 15 KW 48V	590033 - 16.8 KW 24V
GEARBOX MATE- RIAL	COMPOSITE	•	•	•	•	•													
	BRONZE														•		•	•	
	ALUMINIUM														•				•
	STAINLESS						•	•	•	•	•	•	•						
GEARBOX	589454	•																	
	582010		•																
	589156				•	•													
	583051						•	•											
	83052								•	•	•	•	•						
	589557													•	•				
	559775																•	•	•
FUSE	589007 130A							•											
	589008 250A						•				•								
	589009 325A												•						
	589010 400A									•								•	
	589011 500A											•						•	
	589012 200A	•			•	•													
FUSE HOLDER	589006 T1	•			•	•	•	•			•		•						
	589013 T2	•			•	•	•	•	•	•	•	•	•	•	•	•	•	•	•
CONTROLLER	589223 SINGLE PAD			•	•	•	•	•	•	•	•	•	•	•	•	•	•	•	•
	589222 DUAL PAD			•	•	•	•	•	•	•	•	•	•	•	•	•	•	•	•
	589268 SINGLE JOYSTICK			•	•	•	•	•	•	•	•	•	•	•	•	•	•	•	•
	589267 DUAL JOYSTICK			•	•	•	•	•	•	•	•	•	•	•	•	•	•	•	•
	589094 SIMPLE JOYSTICK	•	•		•														
POWER SWITCH BOX	559036 12V/24V									•			•		•				
	559037 24V/48V																	•	
	559038 12V/24V H																	•	•
SPARE ANODES	589350 185TT ANODE						•	•	•	•	•	•	•						
	589550 250/300TT ANODE													•	•	•	•	•	
SPARE PROPELLERS	589451 110TT PROPELLER	•																	
	589455 125TT PROPELLER		•	•															
	589151 140TT PROPELLER				•	•													
	589351 185TT PROPELLER						•	•	•	•	•	•	•						
	589551 250TT RH PROPELLER													•	•				
	589552 250TT LH PROPELLER													•	•				
	589751 300TT LH PROPELLER																	•	•
	589750 300TT RH PROPELLER																	•	•
SPARE DRIVE PINS	559107 110TT DRIVE PIN	•																	
	559018 125TT DRIVE PIN		•	•															
	559018 140TT DRIVE PIN				•	•													
	559017A 185TT DRIVE PIN						•	•	•	•	•	•	•						
SPARE MOTOR SUPPORT BRACKETS	589096 125TT SUPPORT BKT		•	•	•	•													
	589096 140TT SUPPORT BKT																		
	589064 185TT SUPPORT BKT						•	•	•	•	•	•	•						
	589066 250TT SUPPORT BKT													•	•				
	589065 300TT SUPPORT BKT																	•	•
REPLACEMENT BRUSH KITS	B15279 2.0/2.2KW 12V BRUSH KIT		•	•	•	•													
	B15282 3.0/4.0KW 12V BRUSH KIT						•												
	B15283 3.0/4.0KW 24V BRUSH KIT							•											
	B17198 5.0 / 6.0KW 12V / 24V BRUSH KIT									•	•	•	•						
	B15284 8.0KW 24V BRUSH KIT													•	•				
	B13336 10.8KW 24V BRUSH KIT																	•	•
	B12373 15.0KW 48V BRUSH KIT																	•	•

# 3. Thrusters

## Thruster Accessories and Spares

### Thruster Tunnels

- Range of high-quality filament-wound GRP tunnels
- Available in a variety of cut lengths
- Manufactured to Lewmar specifications
- Limited range of steel tubes available

TUNNEL LENGTH		GRP Ø110mm	GRP Ø125mm	GRP Ø140mm	GRP Ø185mm	STEEL Ø185mm	GRP Ø250mm	GRP Ø300mm
CM	FT	(4 1/3")	(5")	(5 1/2")	(7 2/7")	(7 2/7")	(9 5/6")	(11 4/5")
60	1'12"	589401						
75	2' 6"	589402	589410	589101	589300			
100	3' 3"	589403	589411	589102	589301	589321	589501	589700
150	4' 11"		589412	589103	589302	589321	589502	589701
200	6' 7"				589303		589503	589702
300	9' 10"							589703

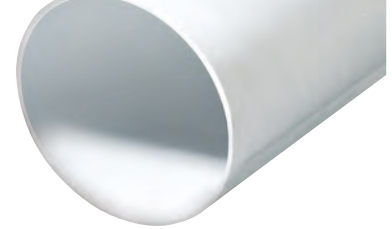

### Stern Kits

To gain total control of your boat, install both a bow and stern thruster, leaving the main engines to propel the boat forward and backward.

- Sturdy stern kits manufactured from durable GRP
- Available to match Lewmar Thrusters, from 140TT to 300TT

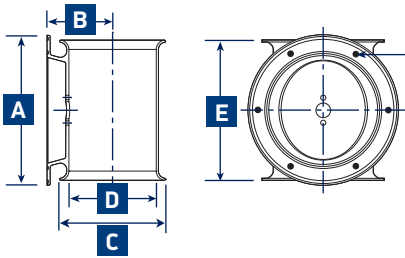

KIT NUMBER	THRUSTER	A		B		C		D		E		NO OF FIXINGS	FIXINGS		FIXING PCD	
		MM	IN	MM	IN	MM	IN	MM	IN	MM	IN		MM	IN		
589110	140TT	240	9 7/16	105	4 1/8	170	6 11/16	140	5 1/2	225	8 7/8	6	M8	206	8 1/8	
589310	185TT	290	11 7/16	130	5 1/8	235	9 1/4	185	7 5/16	320	12 5/8	6	M10	251	9 7/8	
589510	250TT	350	13 3/4	175	6 7/8	310	12 3/16	250	9 13/16	380	14 15/16	6	M10	312	12 5/16	
589710	300TT	384	15 1/8	215	8 7/16	375	14 3/4	300	11 13/16	420	16 9/16	8	M12	334	13 1/8	

### Recommended Spares

	140TT	185TT	250TT/300TT
ANODES	589150	589350	589550

	RT140	RT185	RT250
ANODES	56110026	56110027	56110028

	110TT	125TT	140TT	185TT
DRIVE PINS	559107	559018	559018	559017A

	RT140	RT185	RT250
DRIVE PINS	56110032	56110033	56110034

	140TT	125TT	185TT	250TT	300TT
SUPPORT BRACKETS	589096	589096	589064	589066	589065

	110TT	125TT	140TT/RT	185TT/RT	250TT/RT LH	250TT/RT RH	300TT LH	300TT RH
PROPELLERS	589451	589455	589151	589351	589552	589551	589751	589750

Anode Kit



Propellers



Electric Retractable Thruster Accessories and Spares

Accessories and Spares Selector

DESCRIPTION	RT140		59112004/59112019 IP - 4.0 KW 12V	59112005/59112020 IP - 4.0 KW 12/24V	59112006/59112021 IP - 4.0 KW 24V	59112007/59112022 IP - 5.0 KW 12V	RT185		59112009/59112024 IP - 5.0 KW 24V	59112010/59112025 IP - 6.0 KW 12V	59112011/59112026 IP - 6.0 KW 12/24V	59112012/59112027 IP - 6.0 KW 24V	RT250		
	59111001/59111003 IP - 2.0 KW 12V	59111002/59111004 IP - 2.2 KW 12V					59112008/59112023 IP - 5.0 KW 12/24V	59113001 - 8.0 KW 12/24V					59113002 - 8.0 KW 24V		
FUSE	589007 130A			•	•			•	•						
	589008 250A														
	589009 325A										•	•			
	589010 400A			•			•							•	•
	589011 500A									•					
	589012 200A	•	•												
FUSE HOLDER	589006 T1	•	•		•	•	•	•	•	•	•	•	•	•	•
	589013 T2	•	•	•	•	•	•	•	•	•	•	•	•	•	•
CONTROLLER	589223 SINGLE PAD	•	•	•	•	•	•	•	•	•	•	•	•	•	•
	589222 DUAL PAD	•	•	•	•	•	•	•	•	•	•	•	•	•	•
	589268 SINGLE JOYSTICK	•	•	•	•	•	•	•	•	•	•	•	•	•	•
	589267 DUAL JOYSTICK	•	•	•	•	•	•	•	•	•	•	•	•	•	•
SPARE ANODES	56110026 RT 140 ANODE KIT	•	•												
	56110027 RT 185 ANODE KIT			•	•	•	•	•	•	•	•	•			
	56110028 RT 250 ANODE KIT											•	•	•	
SPARE PROPELLERS	589151 140TT PROPELLER	•	•												
	589351 185TT PROPELLER			•	•	•	•	•	•	•	•	•			
	589551 250TT RH PROPELLER												•	•	
	589552 250TT LH PROPELLER												•	•	
SHEAR PIN KITS	56110032 RT 140 SHEAR PIN KIT	•	•												
	56110033 RT 185 SHEAR PIN KIT			•	•	•	•	•	•	•	•	•			
	56110034 RT 250 PIN & DRIVE KEY												•	•	
TUNNEL AND BRACKET KITS	56110010 RT 140 BKT @ TUNNEL	•	•												
	56110011 RT 185 BKT @ TUNNEL			•	•	•	•	•	•	•	•	•			
	56110012 RT 250 BKT @ TUNNEL												•	•	
DRIVE SHAFT KIT	56110001 RT 140 SHAFT KIT	•	•												
	56110002 RT 185 SHAFT KIT			•	•	•	•	•	•	•	•	•			
	56110003 RT 250 SHAFT KIT												•	•	
GEARBOX	56110004 RT 140 GBOX	•	•												
	56110005 RT 185 GBOX			•	•	•	•	•	•	•	•	•			
	56110006 RT 250 GBOX												•	•	
CAM MECH & LINK	56110007 RT 140 KIT	•	•												
	56110008 RT 185 KIT			•	•	•	•	•	•	•	•	•			
	56110009 RT 250 KIT												•	•	
MICROSWITCH	56110019 RT 140/185 SWITCH KIT	•	•	•	•	•	•	•	•	•	•	•			
	56110020 RT 250 SWITCH KIT												•	•	

### 3. Thrusters

I10TT 1.5kW 12V

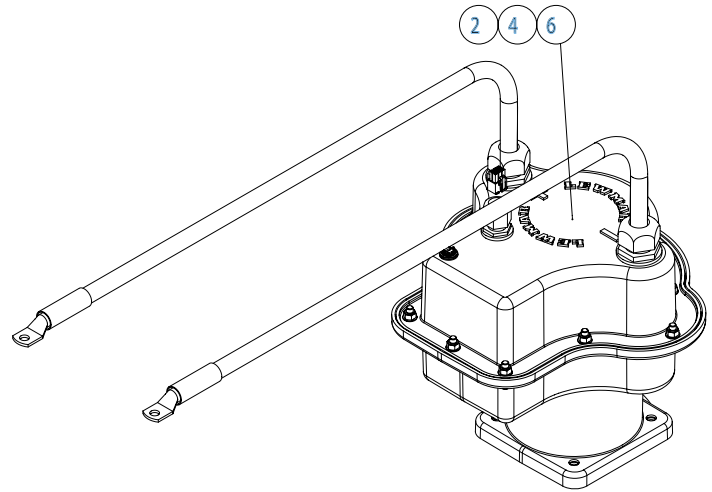
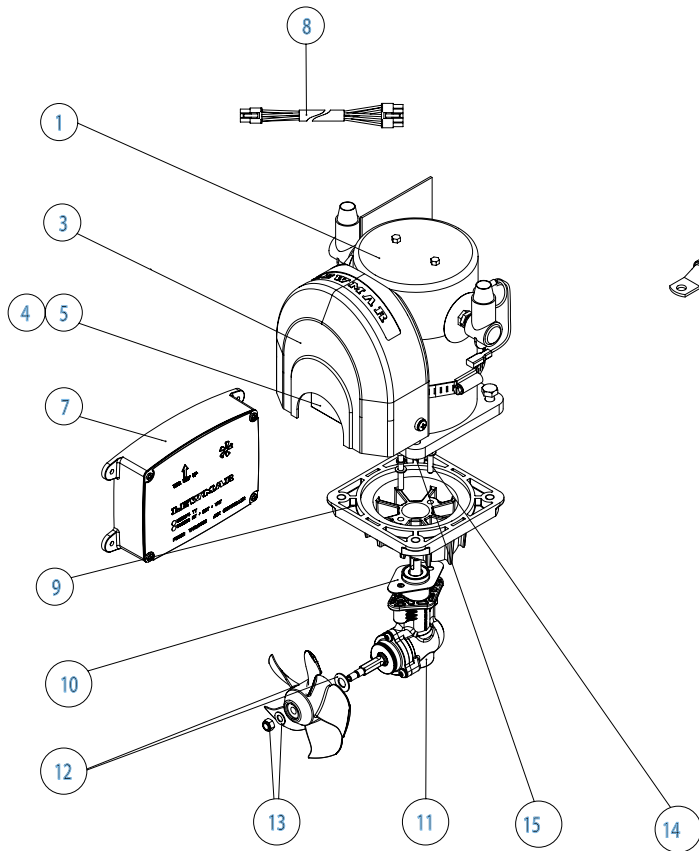

ITEM	PART NO	DESCRIPTION
1	582008	MOTOR ASSY
2	582009	MOTOR ASSY IP
3	553034	COVER, NON-IP
4	812526	SOLENIOD
5	589857	SOLENIOD LOOM, NON-IP
6	589856	SOLENIOD LOOM, IP
7	589274	GEN2 TT ICU
8	589806	2M TT MOTOR LOOM
9	552004	MOUNTING SADDLE
10	552005	TUNNEL GASKET
11	589454	HUB ASSY
12	589451	PROPELLER AND WASHER
13	589453	PROPELLER FIXING KIT
14	589452	INSTALLATION FIXING KIT
15	559107	DRIVE PIN

I25TT 2.0kW 12V

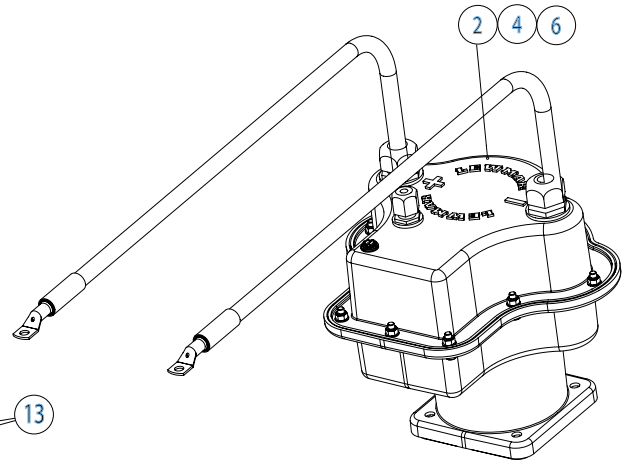
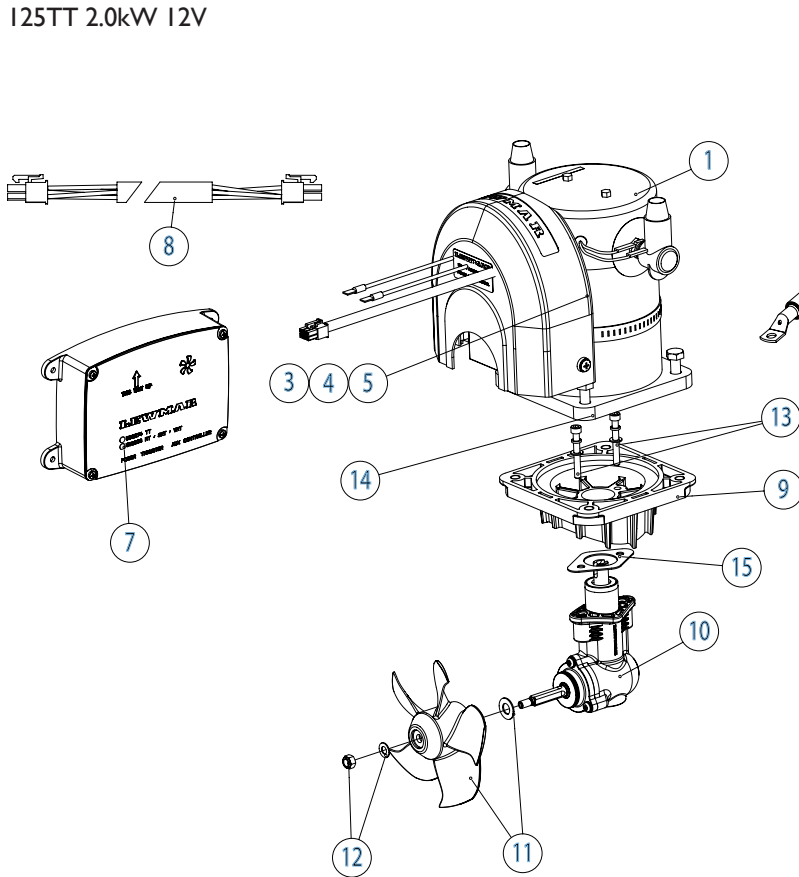

ITEM	PART NO	DESCRIPTION
246	581110	MOTOR ASSY 2.0KW 12V
2	581112	MOTOR ASSY 2.0KW 12V IP
3	553034	COVER NON-IP
4	812526	SOLENIOD 2.0
5	589857	SOLENIOD 2.0 LOOM -NON IP
6	589856	SOLENIOD 2.0 LOOM IP
7	589274	GEN 2 TT ICU
8	589806	2M TT MOTOR LOOM
9	552029	MOUNTING SADDLE
10	582010	HUB ASSY
11	589455	PROPELLER AND WASHER
12	589453	PROPELLER FIXING KIT
13	589452	INSTALLATION FIXING KIT
14	559018	DRIVE PIN
15	552030	TUNNEL GASKET

I40TT 2.2kW 12V

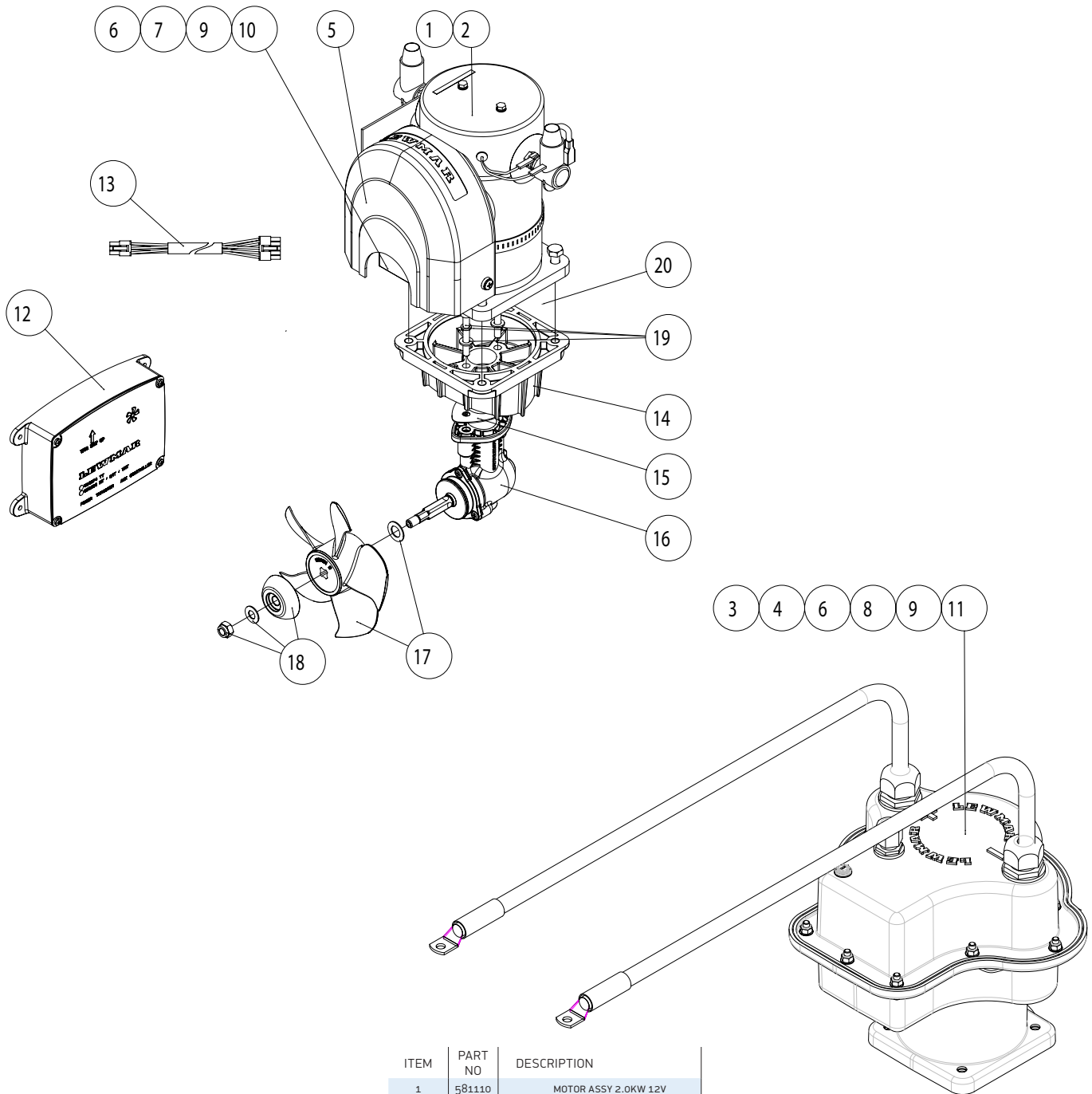

ITEM	PART NO	DESCRIPTION
1	581110	MOTOR ASSY 2.0KW 12V
2	581111	MOTOR ASSY 2.2KW 12V
3	581112	MOTOR ASSY 2.0KW 12V IP
4	581113	MOTOR ASSY 2.2KW 12V IP
5	553034	COVER, NON-IP
6	B12526	SOLENIOD 2.0
7	589857	SOLENIOD 2.0 LOOM, NON-IP
8	589856	SOLENIOD 2.0 LOOM, IP
9	B11126	SOLENIOD 2.2
10	589836	SOLENIOD 2.2 LOOM, NON-IP
11	589844	SOLENIOD 2.2 LOOM, IP
12	589274	GEN2 TT ICU
13	589806	2M TT MOTOR LOOM
14	551052	MOUNTING SADDLE
15	551035	TUNNEL GASKET
16	589156	HUB ASSY
17	589151	PROPELLER AND WASHER
18	589150	PROPELLER ANODE KIT
19	559152	INSTALLATION FIXING KIT
20	559018	DRIVE PIN

# 3. Thrusters

185TT/H - 3.0 to 6.0kW - 12 & 24V

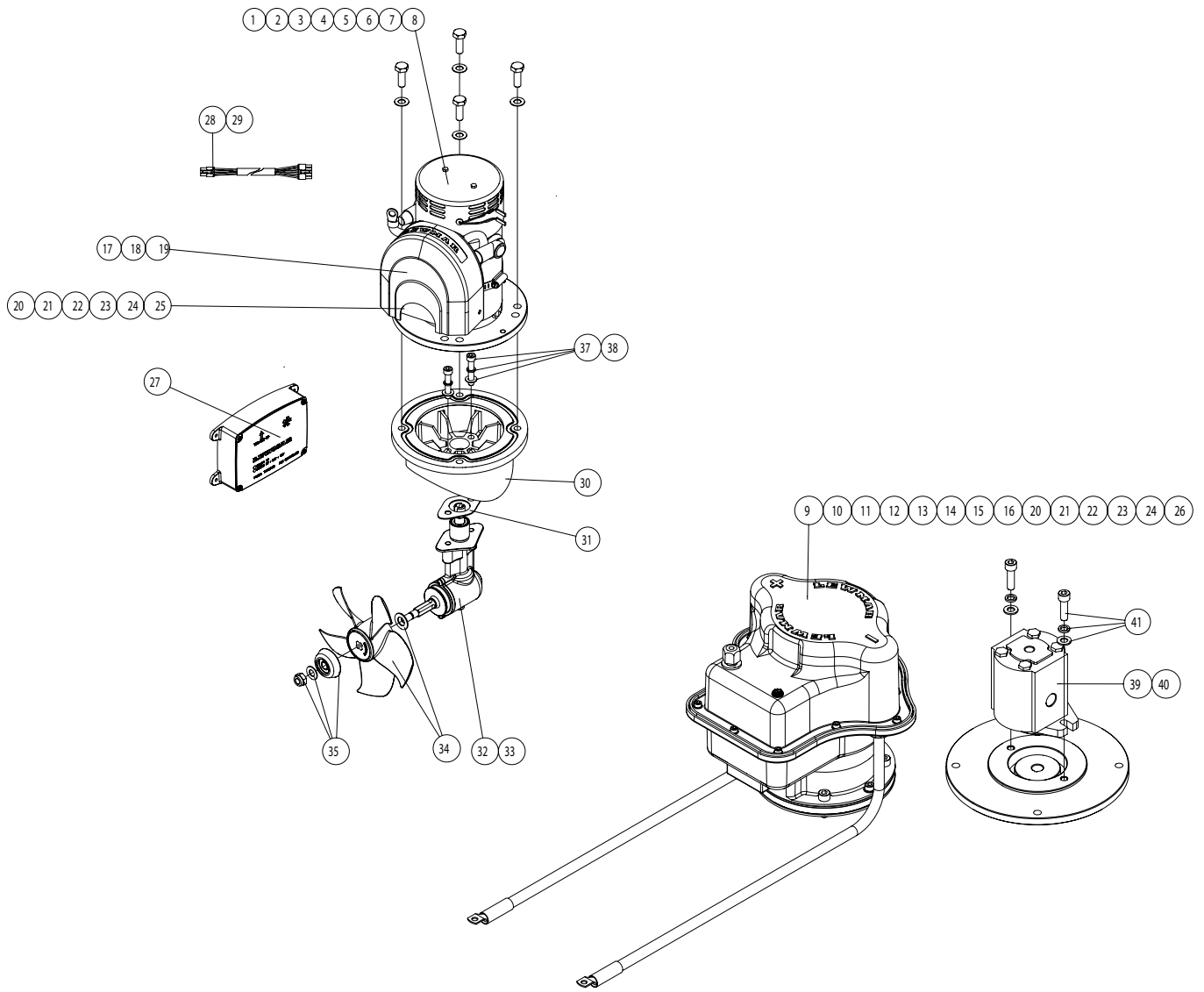

ITEM	PART NO	DESCRIPTION	KW	V
1	583082	185 3.0KW 12V MX	3.0	12
2	583083	185 3.0KW 24V MX	3.0	24
3	583084	185 4.0KW 12V MX	4.0	12
4	583085	185 4.0KW 24V MX	4.0	24
5	583086	185 5.0KW 12V MX	5.0	12
6	583087	185 5.0KW 24V MX	5.0	24
7	583088	185 6.0KW 12V MX	6.0	12
8	583089	185 6.0KW 24V MX	6.0	24
9	583090	185 3.0KW 12V MX IP	3.0	12
10	583091	185 3.0KW 24V MX IP	3.0	24
11	583092	185 4.0KW 12V MX IP	4.0	12
12	583093	185 4.0KW 24V MX IP	4.0	24
13	583094	185 5.0KW 12V MX IP	5.0	12
14	583095	185 5.0KW 24V MX IP	5.0	24
15	583096	185 6.0KW 12V MX IP	6.0	12
16	583097	185 6.0KW 24V MX IP	6.0	24
17	553034	COVER, NON-IP, 3.0	3.0	ALL
18	553036	COVER, NON-IP, 4.0/5.0	4/5.0	ALL
19	555034	COVER, NON-IP, 6.0	6.0	ALL
20	B11126	SOLENIOD 3.0 12V	3.0	12

ITEM	PART NO	DESCRIPTION	KW	V
21	B11127	SOLENIOD 3.0 24V	3.0	24
22	B11128	SOLENIOD 4/5.0 12V	4/5.0	12
23	B11129	SOLENIOD 4/5/6.0 24V	4/5/6.0	24
24	B11130	SOLENIOD 6.0 12V	6.0	12
25	589834	SOLENIOD LOOM		ALL
26	589844	SOLENIOD LOOM IP		ALL
27	589274	GEN2 TT ICU		ALL
28	589806	2M TT MOTOR LOOM		ALL
29	589858	2M TT HYD LOOM (HYDRAULIC ONLY)		ALL
30	553071	MOUNTING SADDLE		ALL
31	553035	TUNNEL GASKET		ALL
32	583051	HUB ASSY 3.0	3.0	ALL
33	583052	HUB ASSY 4/5/6	4/5/6.0	ALL
34	589351	PROPELLER & WASHER		ALL
35	589350	ANODE KIT		ALL
36	559017A	DRIVE PIN		ALL
37	589352	INSTALLATION FIXING KIT	3.0	ALL
38	589355	INSTALLATION FIXING KIT	4/5/6.0	ALL
39	585040	HYD MOTOR 26 CC/REV		5.0CC REV
40	585041	HYD MOTOR 16.8 CC/REV		6.0CC REV
41	589352	INSTALLATION FIXING KIT		ALL

250TT/H - 8.0kW - 24

300TT/H - 10.8 to 15.0kW

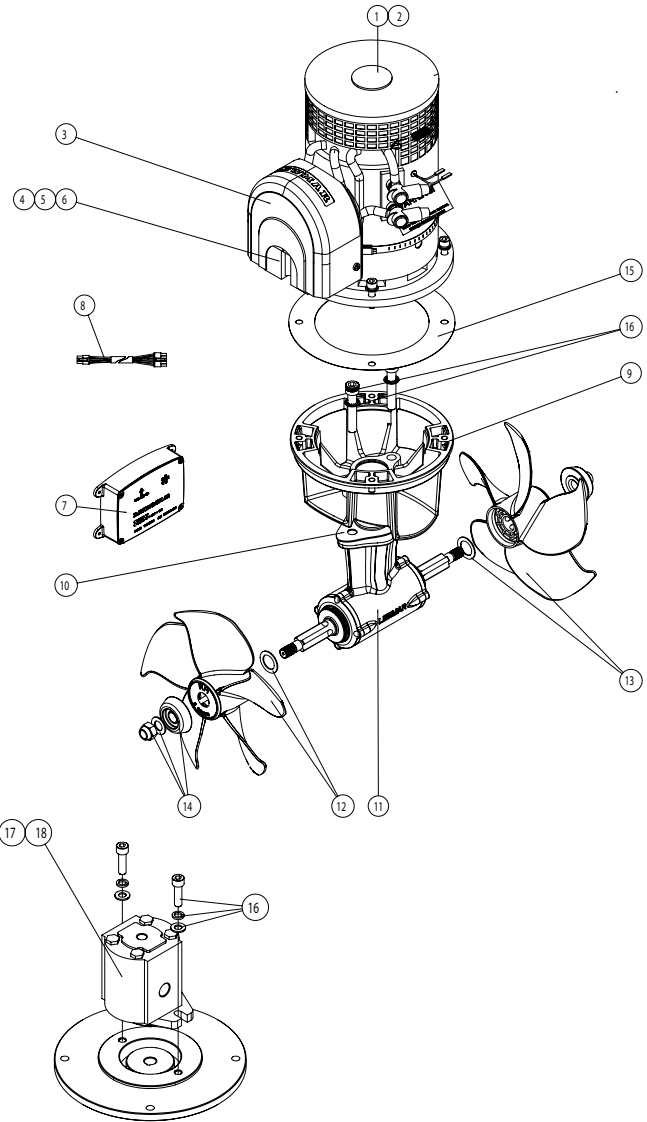
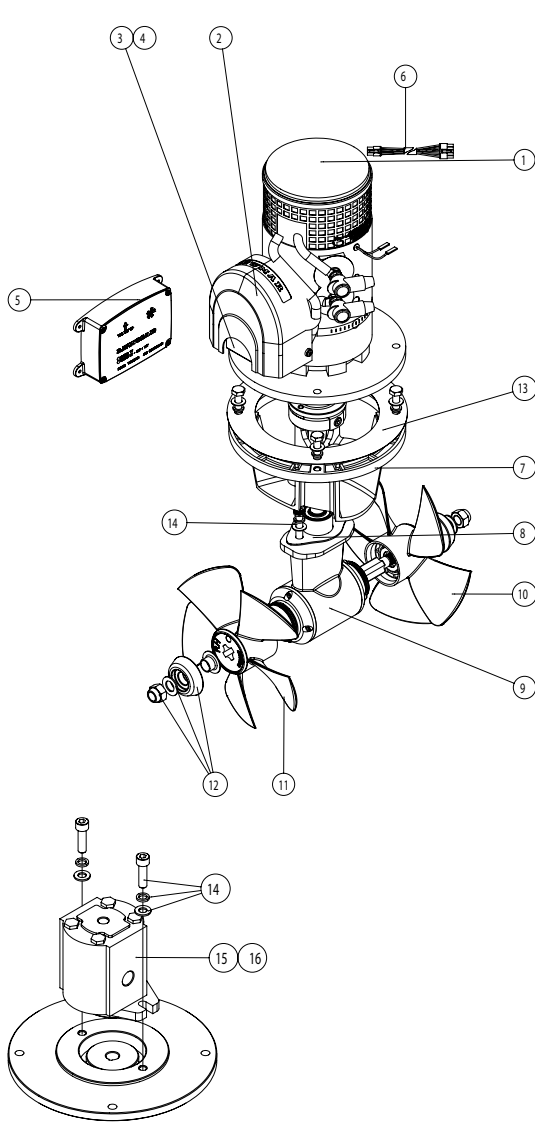

ITEM	PART NO	DESCRIPTION
1	585029	MOTOR ASSY 8.0KW 24V
2	553036	COVER, NON-IP
3	B11129	SOLENIOD 8.0
4	589834	SOLENIOD LOOM
5	589834	GEN2 TT ICU
6	589806	2M TT MOTOR LOOM
7	589858	2M TT HYD LOOM (HYDRAULIC ONLY)
8	555025	MOUNTING SADDLE
9	555035	TUNNEL GASKET
10	589557	HUB ASSY
11	589551	RIGHT HAND PROPELLER & WASHER
12	589552	LEFT HAND PROPELLER & WASHER
13	589150	ANODE KIT
14	555038	PLASTIC WASHER
15	559152	INSTALLATION FIXING KIT
16	585040	HYD MOTOR 26 CC/REV
17	585041	HYD MOTOR 16.8 CC/REV

ITEM	PART NO	DESCRIPTION
1	587032	MOTOR ASSY 10.8KW 24V
2	557030	MOTOR ASSY 15KW 48V
3	555034	COVER, NON-IP
4	B8429	SOLENIOD 10.8KW
5	B11762	SOLENIOD 15KW
6	589834	SOLENIOD LOOM
7	589274	GEN2 TT ICU
8	589806	2M TT MOTOR LOOM
9	589858	2M TT HYD LOOM (HYDRAULIC ONLY)
10	557025	MOUNTING SADDLE
11	557035	TUNNEL GASKET
12	559755	HUB ASSY
13	589750	RIGHT HAND PROPELLER & WASHER
14	589751	LEFT HAND PROPELLER & WASHER
15	589150	ANODE KIT
16	555038	PLASTIC WASHER
17	589752	INSTALLATION FIXING KIT
18	585040	HYD MOTOR 26 CC/REV
19	585041	HYD MOTOR 16.8 CC/REV

# 3. Thrusters

I40RT - 2.0 to 2.2kW - 12V

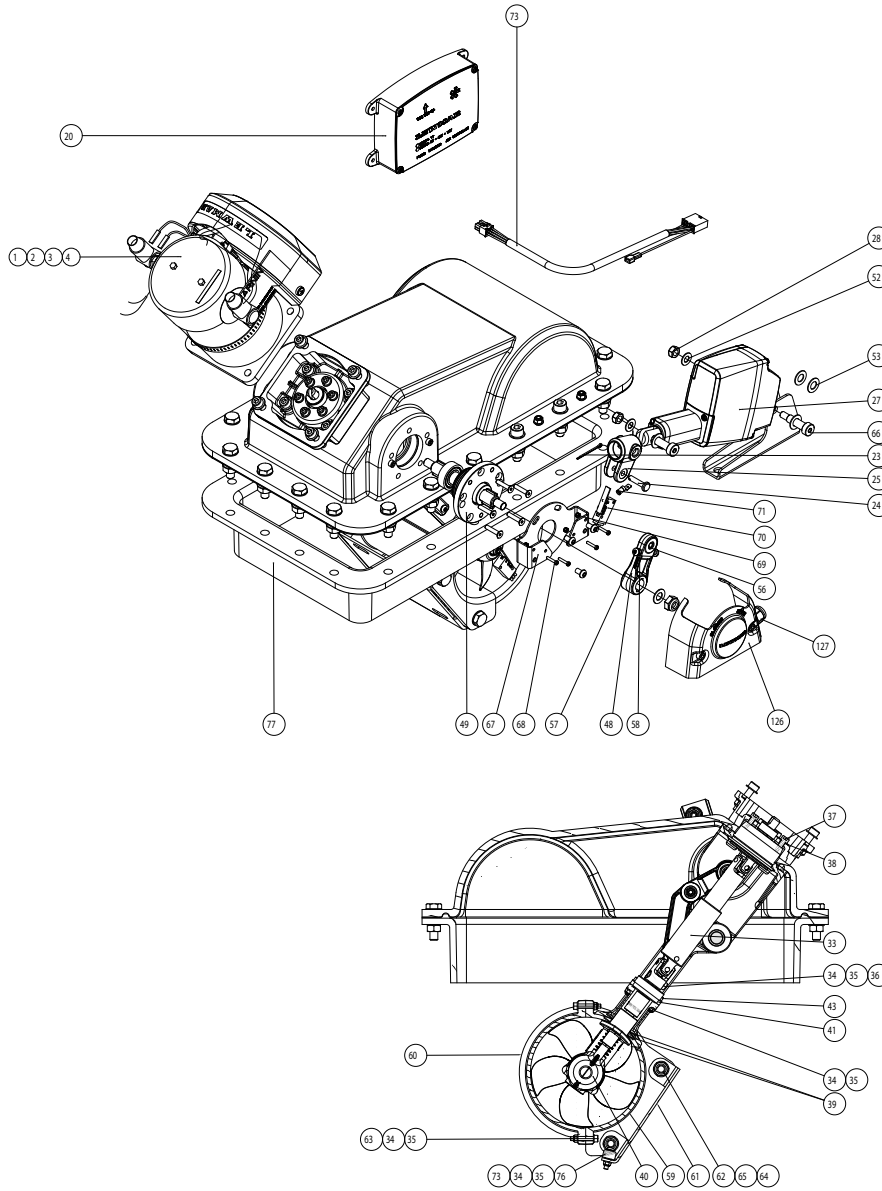

PART NO.	DESCRIPTION	ITEMS INCLUDED (QTY)
581111	140 2.0 KW 12V	1(1)
581112	140 2.2 KW 12V	2(1)
581113	140 2.0 KW 12V IP	3(1)
581114	140 2.2 KW 12V IP	4(1)
589151	140 PROPELLOR	29(1)
589157	140 THRUSTER PROP FIXING KIT	30(1), 31(1), 32(1)
589296	RT GEN2 I.C.U. ASSY	20(1)
589808	GEN2 RT MOTOR LOOM 2M	21(1)
589809	GEN2 RT MOTOR LOOM 5M	22(1)
56110001	RT 140 DRIVE SHAFT KIT	33(1), 34(1), 35(1), 36(1), 37(6), 38(6)
56110004	RT 140 GEARBOX	34(4), 35(8), 39(1), 40(1), 42(4), 43(2), 44(1), 45(1)
56110007	RT 140 CAM MECH WITH LINK	38(2), 46(1), 47(1), 48(1), 49(1), 50(2), 51(2), 52(1), 53(2), 54(3), 55(2), 56(1), 57(2), 58(2)
56110010	RT 140 TUNNEL ASSY WITH BRACKET	34(6), 35(6), 59(1), 60(1), 61(1), 62(4), 63(6), 64(4), 65(8)
56110013	RT ACTUATOR SHEAR PIN KIT	23(1), 24(1)
56110014	RT 140 ACTUATOR 12V KIT	23(1), 24(1), 25(1), 27(1), 28(2), 52(2), 53(4), 66(2)
56110019	RT 140 / 185 MICRO SWITCH ASSY	66(1), 67(2), 68(2), 69(2), 70(1), 71(2)
56110021	RT MICRO SWITCH COVER	126(1), 127(1)
56110022	RT 140 / 185 WIRE LOOM	73(1)
56110026	RT 140 ANODE KIT	34(2), 35(2), 74(3), 75(4), 76(2)
56110029	RT 140 LOWER FLANGE	77(1)
56110032	RT 140 SHEAR PIN KIT	23(1), 24(1), 34(1), 35(1), 36(1), 44(2)



185RT - 4.0 to 6.0kW - 12/24V

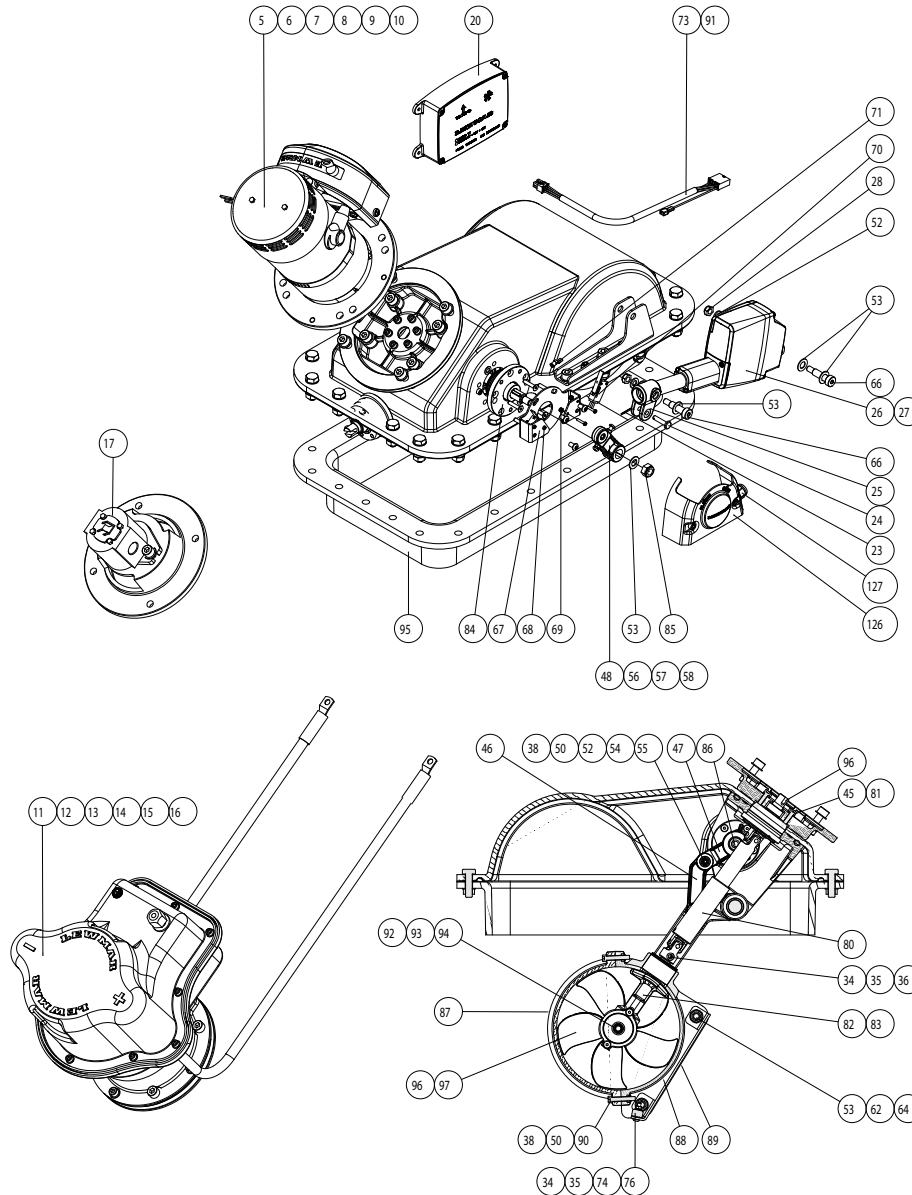

PART NO.	DESCRIPTION	ITEMS INCLUDED (QTY)
583041	185 HYD MOTOR	17(1)
583084	185 4.0KW 12V MX	5(1)
583085	185 4.0KW 24V MX	6(1)
583086	185 5.0KW 12V MX	7(1)
583087	185 5.0KW 24V MX	8(1)
583088	185 6.0KW 12V MX	9(1)
583089	185 6.0KW 24V MX	10(1)
583092	185 4.0KW 12V MX IP	11(1)
583093	185 4.0KW 24V MX IP	12(1)
583094	185 5.0KW 12V MX IP	13(1)
583095	185 5.0KW 24V MX IP	14(1)
583096	185 6.0KW 12V MX IP	15(1)
583097	185 6.0KW 24V MX IP	16(1)
589351	185 PROPELLOR	96(1), 97(1)
589296	RT GEN2 I.C.U. ASSY	20(1)
589808	GEN2 RT MOTOR LOOM 2M	21(1)
589809	GEN2 RT MOTOR LOOM 5M	22(1)
56110002	RT 185 DRIVE SHAFT KIT	34(1), 35(1), 36(1), 45(6), 80(1), 81(6)

PART NO.	DESCRIPTION	ITEMS INCLUDED (QTY)
56110005	RT 185 GEARBOX	82(1), 83(2)
56110008	RT 185 CAM MECH WITH LINK	46(1), 47(1), 48(1), 50(2), 52(1), 53(1), 54(3), 55(2), 56(1), 57(2), 58(2), 84(1), 85(1), 86(1)
56110011	RT 185 TUNNEL ASSY WITH BRACKET	38(1), 50(6), 53(8), 62(4), 64(4), 87(1), 88(1), 89(1), 90(1)
56110013	RT ACTUATOR SHEAR PIN KIT	23(1), 24(1)
56110014	RT ACTUATOR 12V KIT	23(1), 24(1), 25(1), 27(1), 28(2), 52(2), 53(4), 66(2)
56110015	RT ACTUATOR 24V KIT	23(1), 24(1), 25(1), 26(1), 28(2), 52(2), 53(4), 66(2)
56110019	RT 140 / 185 MICRO SWITCH ASSY	66(1), 67(2), 68(2), 69(2), 70(1), 71(2)
56110021	RT MICRO SWITCH COVER	126(1), 127(1)
56110022	RT 140 / 185 WIRE LOOM	73(1)
56110023	RT 140 / 185 HYD WIRE LOOM	91(1)
56110027	RT 185 ANODE KIT	34(2), 35(2), 74(3), 75(4), 76(2), 92(2), 93(2), 94(2)
56110030	RT 185 LOWER FLANGE	95(1)
56110029	RT 185 SHEAR PIN KIT	23(1), 24(1), 36(1), 34(1), 35(1), 96(2)

# 3. Thrusters

250RT - 8.0 to HYD - 12/24V

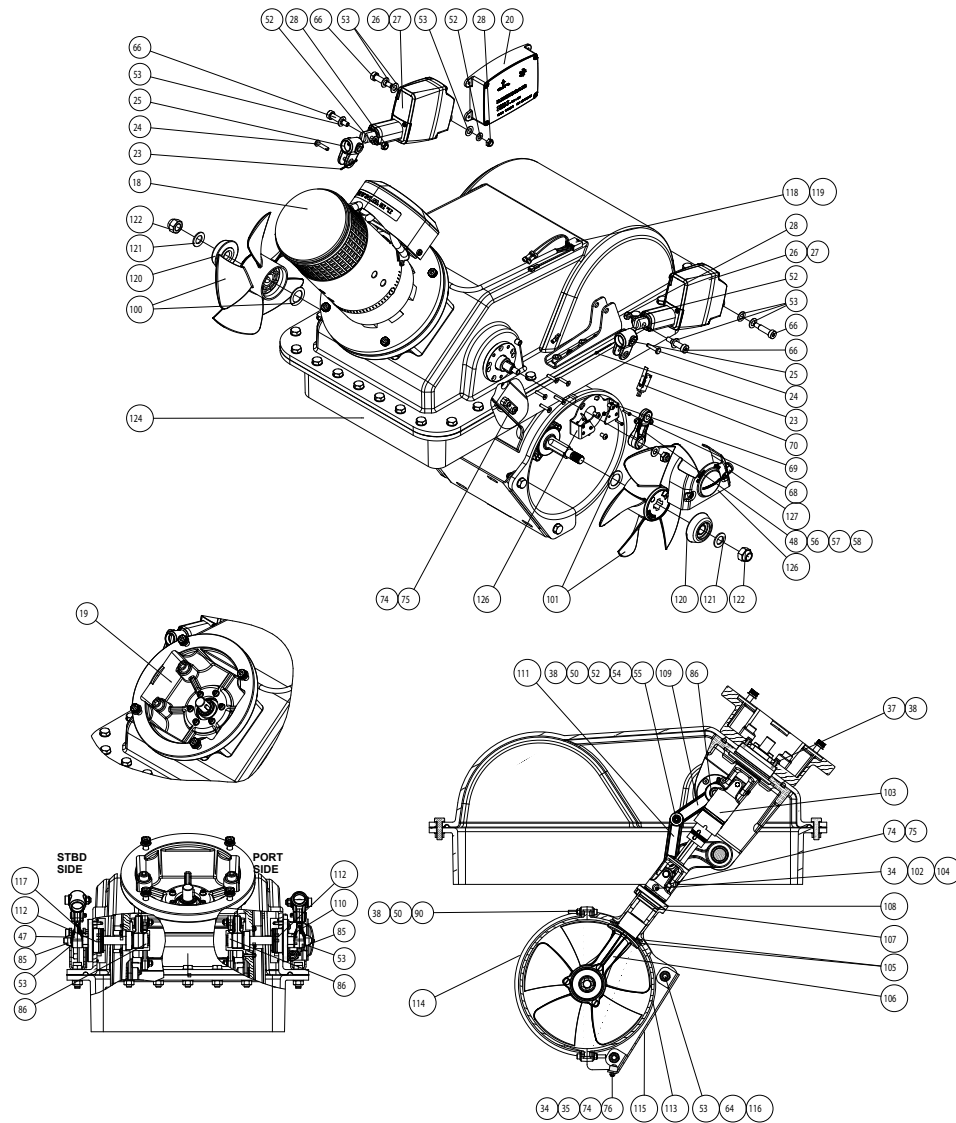



## 4. Hatch & Portlight



As the global leader in the production of sail and powerboat hatches, Lewmar offers an extensive range of solutions, producing over 200,000 hatches and portlights a year. Whether your requirement is a sleek opening port or a robust offshore access hatch, Lewmar has the solution.

Modern trends have led to larger openings and more customized shapes which naturally allow designers to create a signature look and feel to their products.

# 4. Hatch & Portlight

## CE Regulations

The CE Regulations apply to craft up to 24m in length that are sold in the European Union. Although the Regulations may not apply to your boat, they are a useful guide for small craft throughout the world.

- The Regulations have Design Categories for boats based on their intended usage and propulsion (sail or power). Boats built to CE Regulations are fitted with a plate showing the Design Category.
- All Lewmar hatches and portlights are for Design Category A (Ocean Sailing) or Design Category B (Offshore Sailing).
- The Regulations divide up the hull and deck into four specific 'areas'. These are shown below.

- For craft with a freeboard greater than 1/12 of its overall length, the hull is split into Area 1 and Area 2B. Please refer to the Recreational Craft Directive 94/25/EC.
- A product that is suitable for fitting to an area for which it is approved is suitable for all the areas below its category. For example, a portlight that is approved for Area 2A may also be fitted to Areas 3 and 4, but not Areas 1 or 2B.
- All the hatches and portlights in this publication are CE Approved for the areas indicated on the product pages.
- Lewmar warranties are invalid if the product is installed in an area where it is not intended, and if the installation fails to meet the requirements of the CE Regulations.

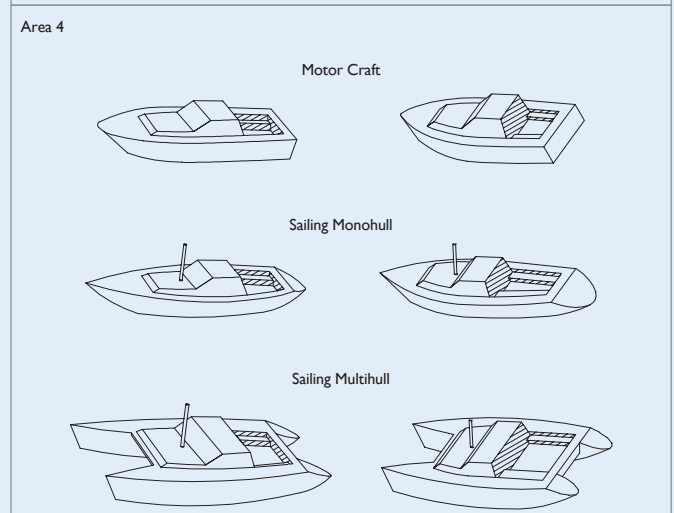
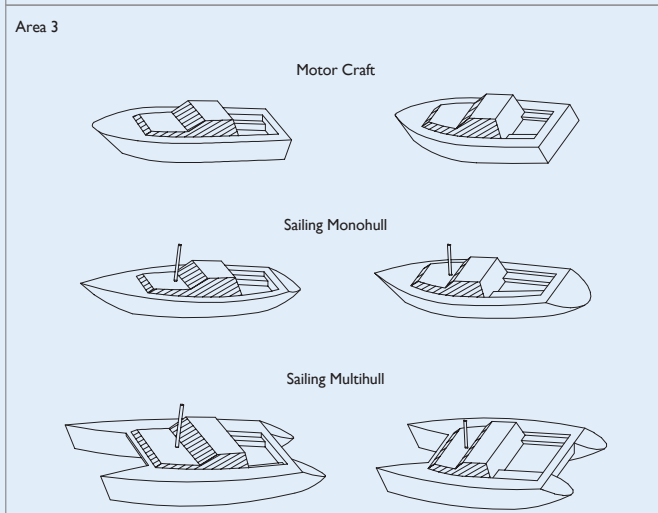
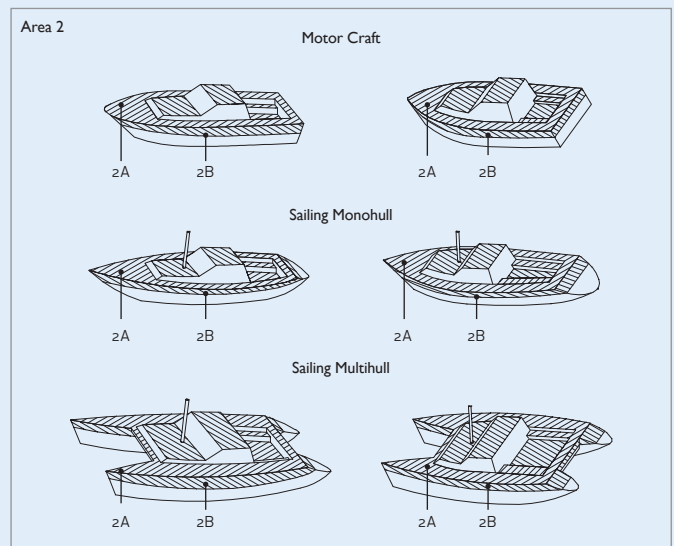
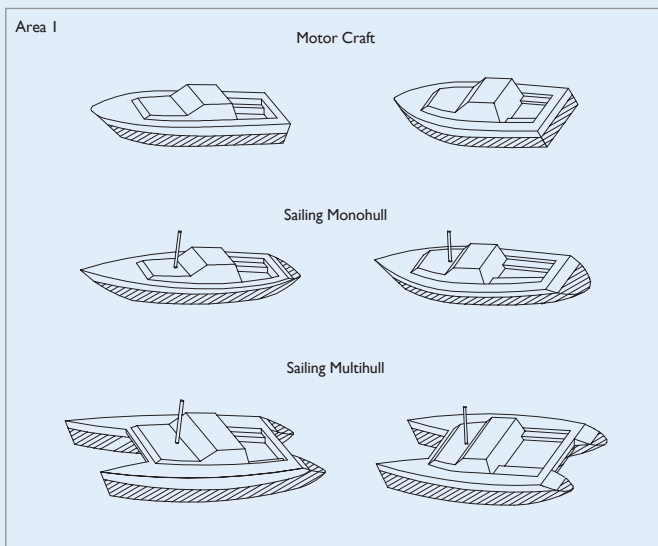

### Hatches

DESCRIPTION	SIZES	CATEGORY	AREA
LOW PROFILE	ALL	A	2A, 3 & 4
MEDIUM PROFILE	ALL	A	2A, 3 & 4
OCEAN HATCH	ALL	A	2A, 3 & 4
FLUSH HATCH	ALL	A	2A, 3 & 4
PILOT HATCH	ALL	A	3 & 4

### Portlights

DESCRIPTION	SIZES	CATEGORY	AREA	DESCRIPTION	SIZES	CATEGORY	AREA
STANDARD	ALL	A	2A, 3 & 4	STAINLESS	0,1,1RE,7RE,8	B	1, 2, 3 & 4
ATLANTIC	10, 30, 32	A	1, 2, 3 & 4	STAINLESS	ROUND	A	1, 2, 3 & 4
ATLANTIC	40, 60	A	2A, 3 & 4	FLUSH MITRE	0, 1, 3 & 4	A	2A, 2B, 3 & 4
STAINLESS	0,1,1RE,7RE,8	A	2A, 3 & 4				

## The Lewmar Hatch Range

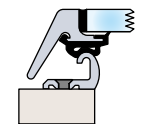
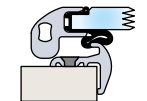
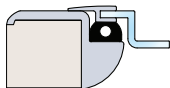
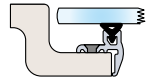
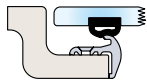

## Flush Hatches

### Page 134 Flush Hatch 2G

- Sleek, modern look
- Fits seamlessly into a specially designed recess in the deck
- Seal mounted on the acrylic
- Acrylic has band of paint to conceal deck & frame when installed
- Custom configuration available including stainless steel hinge, handle and stay.

### Page 136 Flush Hatch 3G

- All the benefits of the flush hatch
- Lower frame mounted seal
- All external fittings flush to the acrylic

### Page 140 Custom Flush Hatches

- Stainless Flush Hatch 2G
- Horizon Hatch - Acrylic curved to match deck camber
- GRP Frame Hatch - Bonded directly onto the deck

## Framed Hatches

### Page 143 Ultra-Low Profile Hatch

- 6mm above-deck height
- Easy to retrofit for flush aesthetic

### Page 133 Low Profile Hatch

- Soft styling and sleek looks
- Does not require deck recess to install
- Available in Round and D-Hatch configuration

### Page 146 Medium Profile Hatch

- Ideal as a foredeck hatch on larger offshore yachts
- Provides greater strength and durability
- Thicker acrylic and deeper frame sections
- Medium Profile styled to match Low Profile for mixed deck specifications

### Page 148 Ocean Hatch

- Ultimate protection against the elements
- Classical styling and rugged construction
- Fitted to thousands of boats throughout the world
- 2 profiles available with or without flange

### Page 150 Custom Hatches

- Stainless Hatch
- Integral Privacy Blind
- Flybridge Hatch
- Pilot Hatch
- Powerboat Hatch
- Washboard Hatch
- Companionway Door
- Crew Door

### Page 161 Hatch Spares and Accessories

- Flyscreens
- Spare acrylics
- Hinge spares
- Hatch Identification Guide

## 4. Hatch & Portlight



### Flush Hatch 2G

Lewmar pioneered the production flush hatch platform back in 2006, bringing superyacht styling into volume boat production. The precision of the fit makes for a sleek, modern look and means no more stubbed toes for boat owners.

- Clean aesthetics
- EPDM seal provide completely watertight structure
- Water drained effortlessly away by deck-moulded channels
- Strong, stylish handles and hinges
- Trimkit fit all standard sizes
- Dark grey acrylic option keeps cabin cooler
- Custom sizes available
- Available with stainless steel hatch furniture
- Full range of spare parts available on-line [www.lewmar.com](http://www.lewmar.com)



#### Flush Hatch Standard Sizes



Size 10

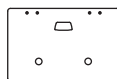

Size 20

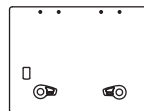

Size 30

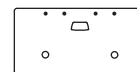

Size 41

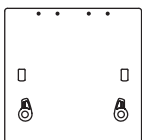

Size 44\*

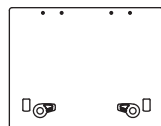

Size 54\*

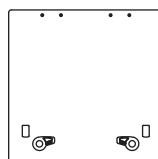

Size 60

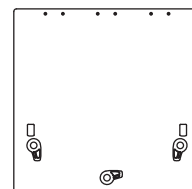

Size 70



\* Minimum size for ISO 9094 escape hatches.



### Flush Hatch 2G Standard Specifications

- White lower frame
- Black exterior moulding
- Grey Interior moulding
- Acrylic colours: Grey or Dark Grey
- Size 20 and 41 supplied with friction lever
- Other sizes use 1 or 2 stays
- Hatches should be fitted to a flat surface with a maximum tolerance of +/- 1mm
- Cutout dimensions changes if a trim is used: Add 4mm to X1 & Y1 and 2mm to R1.
- Fastening size: for lower frame section use 5mm CSK screws No. 10 UNC 2BA
- Fastening size: at the hinge section use M6 (1/4")

### Flush Hatch Dimensions

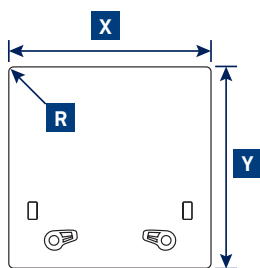

### Flush Hatch Cut-outs

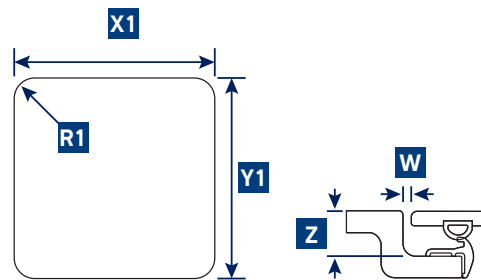

PART NO GREY ACRYLIC	PART NO DARK GREY ACRYLIC	SIZE	W LOWER FRAME FLANGE		W HINGE GAP		OVERALL DIMENSIONS						CUT-OUT DIMENSIONS						ACRYLIC WINDOW THICKNESS		WEIGHT			
			MM	IN	MM	IN	X WIDTH		Y LENGTH		Z DEPTH		R RADI		X1 WIDTH		Y1 LENGTH		R1 RADI		MM	IN	KG	LB
39910012	39910812	10	15	9/16	11	11/64	330	13	330	13	31	1 1/4	10	3/8	260	10 1/4	260	10 1/4	42.5	1 11/16	12	1/2	2.3	5
39920012	39920812	20	15	9/16	11	11/64	417	16 7/16	272	10 11/16	31	1 1/4	10	3/8	347	13 11/16	202	7 15/16	42.5	1 11/16	12	1/2	2.4	5.3
39930012	39930812	30	15	9/16	11	11/64	527	20 3/4	397	15 5/8	31	1 1/4	10	3/8	457	18	327	12 7/8	42.5	1 11/16	12	1/2	4.7	10.3
39941012	39941812	41	15	9/16	11	11/64	491	19 5/16	246	9 1/16	31	1 1/4	10	3/8	421	16 9/16	176	6 15/16	42.5	1 11/16	12	1/2	2.6	5.8
39944012	39944812	44	15	9/16	11	11/64	512	20 3/16	512	20 3/16	31	1 1/4	10	3/8	442	17 3/8	442	17 3/8	42.5	1 11/16	12	1/2	5.4	12
39954012	39954812	54	15	9/16	11	11/64	577	22 11/16	462	18 3/16	31	1 1/4	10	3/8	507	19 15/16	392	15 7/16	42.5	1 11/16	12	1/2	5.5	12.1
39960012	39960812	60	15	9/16	11	11/64	577	22 11/16	577	22 11/16	31	1 1/4	10	3/8	507	19 15/16	507	19 15/16	42.5	1 11/16	15	9/16	7.1	16
39970012	39970812	70	15	9/16	11	11/64	697	27 1/2	697	27 1/2	31	1 1/4	10	3/8	627	24 11/16	627	24 11/16	42.5	1 11/16	15	9/16	11	24

## 4. Hatch & Portlight



### Flush Hatch 3G

With improved manufacturing techniques, the Flush Hatch 3G continues to push the envelope of hatch design and has quickly become a staple design element in many new yachts. A tough, tinted acrylic panel is all that can be seen on deck.

- Lower frame mounted seal
- Strengthened, extruded aluminium frame hidden discreetly below deck
- Completely flush fittings
- Exterior handle available for foredeck use
- Interchangeable with Flush Hatch 2G
- Built in locking mechanism



#### Flush 3G Hatch Standard Sizes

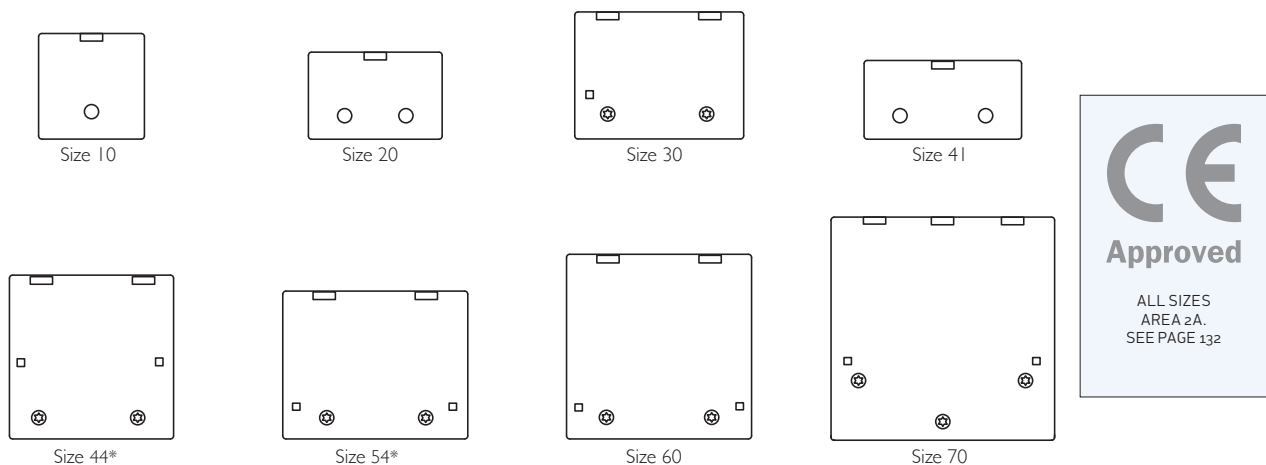

\* Minimum size for ISO 9094 escape hatches.  
Hatch must have external handle option for use in ISO 9094



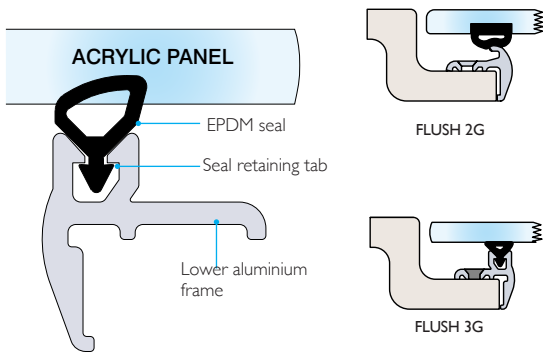

### Flush Hatch 3G Standard Specifications

- White lower frame
- Black mouldings
- Acrylic colours grey or dark grey
- Size 10, 20 and 41 supplied with friction hinges and plain flush exterior handle caps.
- Size 30, 44, 54, 60 and 70 supplied with 1 or 2 stays and winch handle opening handles

### Flush Hatch 3G Dimensions

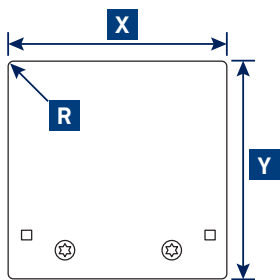

### Flush Hatch 3G Cut-outs

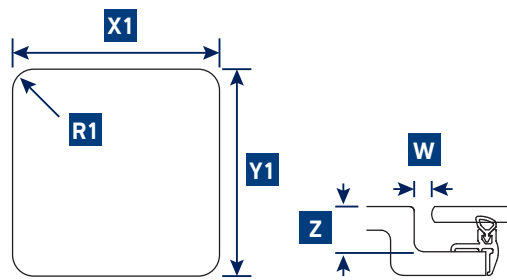

PART NO GREY ACRYLIC	PART NO DARK GREY ACRYLIC	SIZE	W LOWER FRAME FLANGE		W HINGE GAP		OVERALL DIMENSIONS								CUT-OUT DIMENSIONS						ACRYLIC WINDOW THICKNESS		WEIGHT	
			MM	IN	MM	IN	X WIDTH		Y LENGTH		Z DEPTH		R RADI		X1 WIDTH		Y1 LENGTH		R1 RADI		MM	IN	KG	LB
399104996	399104924	10	15	9/16	11	11/64	330	13	330	13	31	1 1/4	10	3/8	260	10 1/4	260	10 1/4	42.5	1 11/16	10	3/8	2.1	4.6
399204996	399204924	20	15	9/16	11	11/64	417	16 7/16	272	10 11/16	31	1 1/4	10	3/8	347	13 11/16	202	7 15/16	42.5	1 11/16	10	3/8	2.2	4.8
399304995	399304923	30	15	9/16	11	11/64	527	20 3/4	397	15 5/8	31	1 1/4	10	3/8	457	18	327	12 7/8	42.5	1 11/16	10	3/8	2.9	8.6
399414996	399414924	41	15	9/16	11	11/64	491	19 5/16	246	9 1/16	31	1 1/4	10	3/8	421	16 9/16	176	6 15/16	42.5	1 11/16	10	3/8	2.3	5.0
399444995	399444923	44	15	9/16	11	11/64	512	20 3/16	512	20 3/16	31	1 1/4	10	3/8	442	17 3/8	442	17 3/8	42.5	1 11/16	10	3/8	4.5	9.9
399544995	399544923	54	15	9/16	11	11/64	577	22 11/16	462	18 3/16	31	1 1/4	10	3/8	507	19 15/16	392	15 7/16	42.5	1 11/16	10	3/8	4.6	10.1
399604995	399604923	60	15	9/16	11	11/64	577	22 11/16	577	22 11/16	31	1 1/4	10	3/8	507	19 15/16	507	19 15/16	42.5	1 11/16	12	1/2	6.2	13.7
399704995	399704923	70	15	9/16	11	11/64	697	27 1/2	697	27 1/2	31	1 1/4	10	3/8	627	24 11/16	627	24 11/16	42.5	1 11/16	12	1/2	9.0	19.8

PLEASE NOTE WINCH HANDLE OPENING DOES NOT MEET THE REQUIREMENTS OF DESIGNATED FIRE EXITS IN THE DRAFT FOR THE NEW VERSION OF ISO9094

## 4. Hatch & Portlight

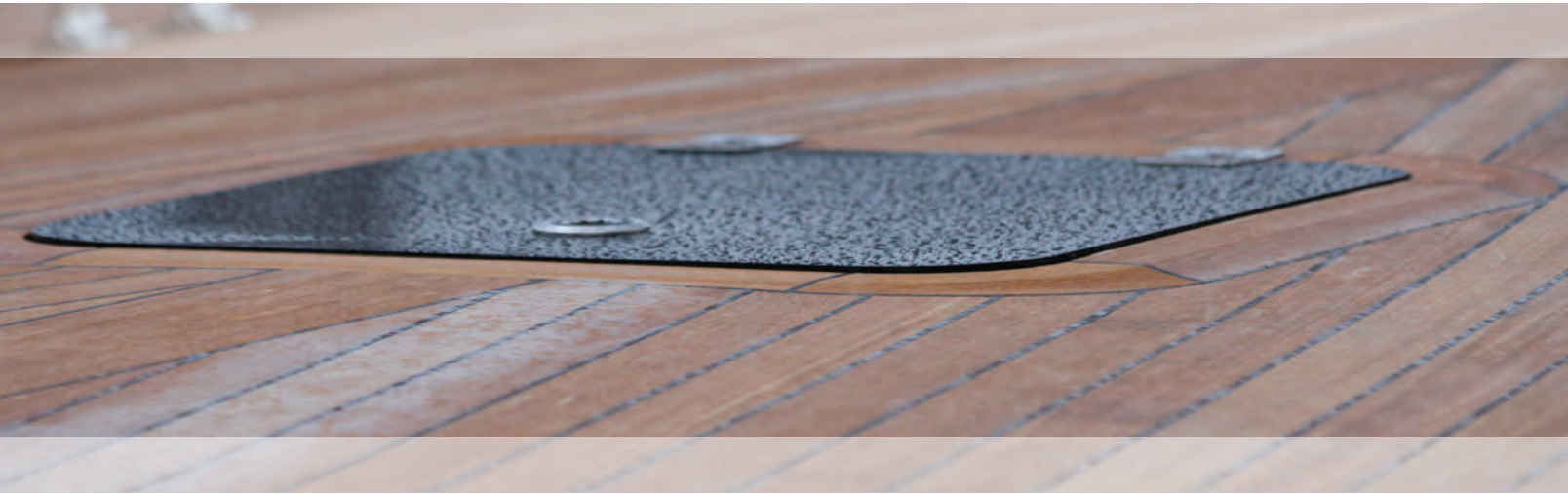

### Flush Hatch 2G with Stainless Steel furniture

At Lewmar, we are constantly seeking to improve our product range to suit evolving design trends. The new range of stainless steel hatch fittings are designed for the Flush Hatch Range, offering a stylish interior and exterior aesthetic.

- Hatch can be opened from the outside using a standard winch handle
- Locking mechanism contained in interior handle
- Effortless operation
- Closer fit to the deck along the hinge edge
- All the features of the Flush Hatch Range
- White aluminium lower frame
- Stainless Steel handles, hinges and stay
- Grey or Dark Grey Acrylic

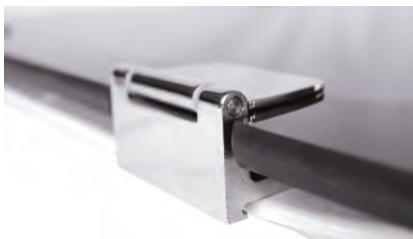

PART NO GREY ACRYLIC	PART NO DARK GREY ACRYLIC	SIZE	LOWER FRAME FLANGE		OVERALL DIMENSIONS								CUT-OUT DIMENSIONS						ACRYLIC WINDOW THICKNESS	
			MM	IN	X WIDTH		Y LENGTH		Z DEPTH		R RADII		X1 WIDTH		Y1 LENGTH		R1 RADII			
					MM	IN	MM	IN	MM	IN	MM	IN	MM	IN	MM	IN	MM	IN		
399441999	399441910	44	15	9/16	512	20 3/16	512	20 3/16	31	1 1/4	10	3/8	442	17 3/8	442	17 3/8	42.5	1 11/16	12	1/2
399601999	399601910	60	15	9/16	577	22 11/16	577	22 11/16	31	1 1/4	10	3/8	507	19 15/16	507	19 15/16	42.5	1 11/16	15	9/16
399701999	399701910	70	15	9/16	697	27 1/2	697	27 1/2	31	1 1/4	10	3/8	627	24 11/16	627	24 11/16	42.5	1 11/16	15	9/16

PLEASE NOTE WINCH HANDLE OPENING DOES NOT MEET THE REQUIREMENTS OF DESIGNATED FIRE EXITS IN THE DRAFT FOR THE NEW VERSION OF ISO9094



## Custom Sized Flush Hatches

Lewmar manufacture custom size hatches in high volume for many boat builders. The table below list the most common sizes. Please note that trimkits are not available on custom size hatches.

### Standard Specifications

- Silver lower frame
- Grey exterior moulding
- Grey Interior moulding
- Grey Acrylic

### White Specifications

- White lower frame
- Black exterior moulding
- Grey Interior moulding
- Grey Acrylic

PART NUMBER	SPECIFICATION	OVERALL DIMENSIONS										CUT-OUT DIMENSIONS						ACRYLIC WINDOW THICKNESS			
		W LOWER FRAME FLANGE		W HINGE GAP		X WIDTH		Y LENGTH		Z DEPTH		R RADII		X1 WIDTH		Y1 LENGTH				R1 RADII	
		MM	IN	MM	IN	MM	IN	MM	IN	MM	IN	MM	IN	MM	IN	MM	IN	MM	IN	MM	IN
30190400	STANDARD	15	9/16	11	11/64	575	22 5/8	284	11 3/16	31	1 1/4	10	3/8	505	19 7/8	214	8 7/16	42.5	1 11/16	12	1/2
30190500	STANDARD	15	9/16	11	11/64	575	22 5/8	551	21 11/16	31	1 1/4	10	3/8	505	19 7/8	481	18 15/16	42.5	1 11/16	12	1/2
30190600	STANDARD	15	9/16	11	11/64	575	22 5/8	773	30 7/16	31	1 1/4	10	3/8	505	19 7/8	703	27 11/16	42.5	1 11/16	12	1/2
30195400	STANDARD	15	9/16	11	11/64	330	13	329	12 15/16	31	1 1/4	10	3/8	260	10 1/4	259	10 3/16	42.5	1 11/16	12	1/2
30193500	WHITE	15	9/16	11	11/64	210	8 1/4	400	15 3/4	31	1 1/4	10	3/8	140	5 1/2	330	13	42.5	1 11/16	12	1/2

### Custom Flush Hatch Design Options

#### Custom Radius Corners

As a further styling aid, Lewmar can manufacture flush hatches with custom radii on the corners.



#### Alloy Lid

Lewmar can supply flush hatches with a plain aluminium panel in place of the acrylic. Teak, or other deck finishes, can then be applied over the top and appropriate handles fitted.



#### Bent Flush

Lewmar has the capability to bend the framework and acrylic panel to match coachroof curvatures.



#### White Acrylic

Opaque white acrylic can be specified. This is particularly useful on heads' ventilation hatches, deck lockers or where privacy is a prime concern.



#### Chamfered Acrylic Edges

The edges of flush hatch acrylics can be chamfered. This achieves a flush look when the deck recess cannot be made to exact specification.



## 4. Hatch & Portlight



### Horizon Hatch

The Horizon Hatch has a lid that is curved to match the camber of the deck. This results in a cleaner aesthetic, especially on sailing boat decks where it is often more difficult to use a conventional flat hatch. Innovative design ensures that sealing and watertight integrity are not compromised.

Horizon Hatches are customised to individual yacht designs. Please contact your Lewmar representative at an early stage in the design process to discuss your requirements.

- Machined and polished acrylic to match cambered decks
- Acrylic mounted seal
- Strong, flat aluminium frame
- Completely flush exterior fittings
- Exterior handle available for foredeck use
- Built-in locking mechanism





## GRP Frame Hatch

Lewmar's premium flush composite hatch offers a flexible solution with sizing to match OEM requirements, providing an ultimate flush finish from the outside and sleek smooth finish from the inside.

The frame is bonded into the deck structure during the boat building process.

- Fitted with stainless steel handles and gas-strut supports
- Concealed heavy duty stainless steel hinges for a durable sturdy hatch that closes flush while allowing the acrylic to have sharper angles allowing a tighter fit with the deck aperture
- Lower frame made of GRP (glass-reinforced plastic) can be bonded into the boat to achieve a fully flush effect
- Lower frame configured to accept customer's preferred drainage positions
- Acrylic, Cambered acrylic or Glass lid options available.



PART NUMBER	SIZE
399355900	35
399605900	60
399705900	70

## 4. Hatch & Portlight



### Ultra-Low Profile Hatch

Following trends towards flush, clean lines, Lewmar have developed a robust, elegant, ultra-slim hatch to minimise impact on deck aesthetics while following the design principles of the proven low profile system.

Conceived as a product for boat builders and owners, the Ultra-low Profile Hatch can be incorporated into new designs with ease while also offering a retrofit solution in current Lewmar installations. As the perfect blend of utility and elegance, the design uses multiple seal profiles to guarantee compression and excellent water-shedding capability.

The Ultra-low Profile Hatch is a revolutionary approach to framed hatch design, supplying strength, beauty and safety.

- Available in industry-standard Lewmar sizes
- Re-styled hinges provide an elegant internal aspect
- Seal profiles are designed to deflect water away from the aperture
- Gas struts ensure easy opening and securing
- Above-deck height of only 6mm





## Low Profile Hatch

The Low Profile Hatch has soft styling and sleek looks, ideal for use on a powerboat. Smaller ventilation hatches are suitable for any deck location on sailboats, while the larger sizes can be used as foredeck hatches on smaller to mid size yachts.

- Outside handles allow the hatch to be opened from on deck if it is not locked
- Low profile hatches open up to 180° (round hatches open to 170°)
- Friction levers hold the lid open in any position up to 95°
- Anodised aluminium frame for corrosion resistance
- Curved upper frame profile for strength as well as modern styling
- Available in Round and D-Hatch configuration, with grey or white acrylic
- Full range of spare parts available on-line [www.lewmar.com](http://www.lewmar.com)

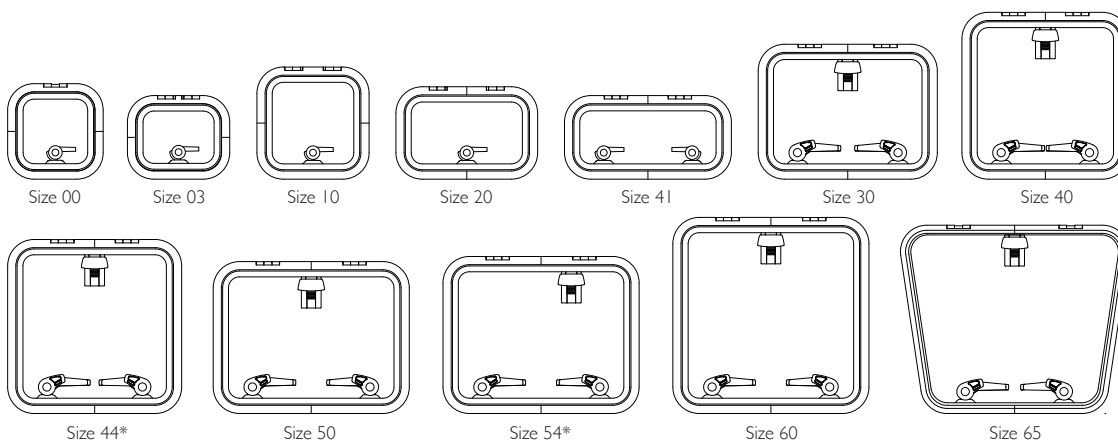

\* Minimum size for ISO 9094 escape hatches

## 4. Hatch & Portlight

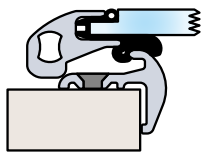
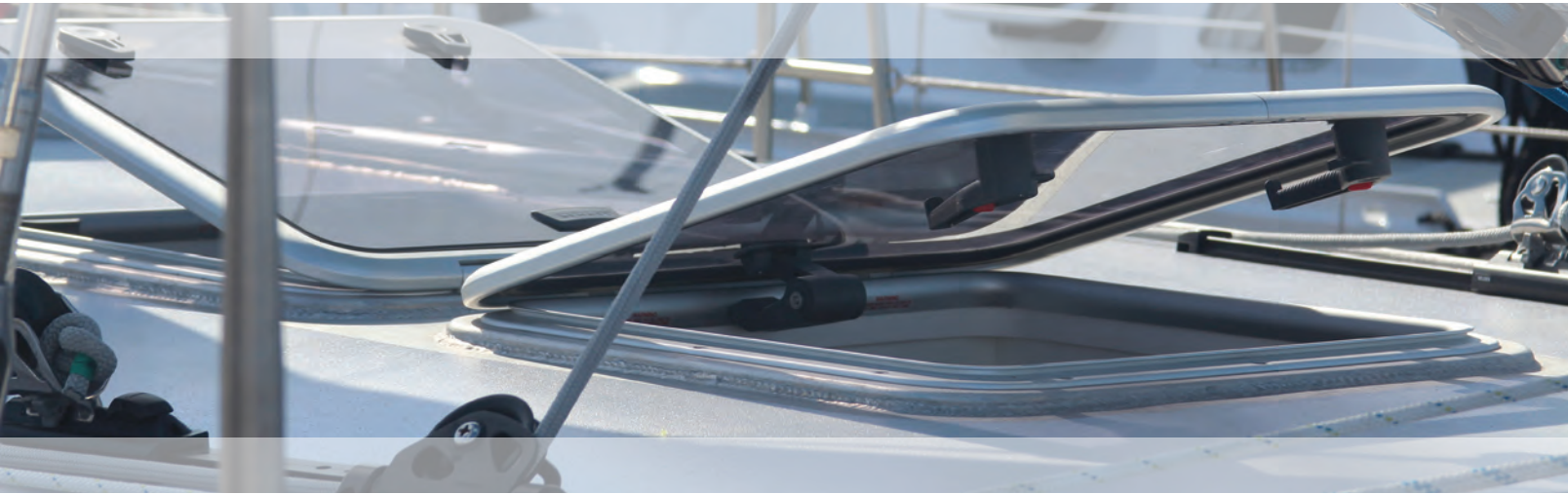

### Low Profile Hatch Standard Specifications

- Grey mouldings
- Acrylic colours grey, clear or white
- Size 30 - 65 supplied with friction hinges as standard
- Simple and easy maintenance on parts

### Low Profile Hatch Dimensions

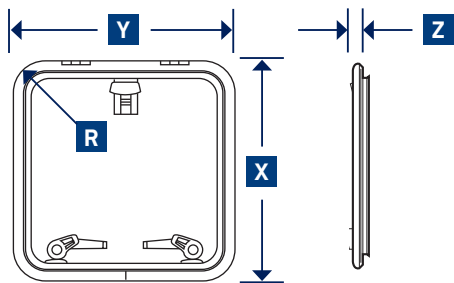

### Low Profile Hatch Cut-outs

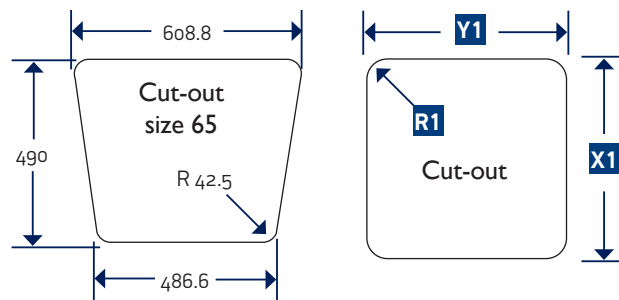

PART NUMBER FRICTION LEVER LID	PART NUMBER HATCH WITH STAY	SIZE	LOWER FRAME FLANGE		OVERALL DIMENSIONS								CUT-OUT DIMENSIONS CHANGE IF TRIMKITS ARE USED						HATCH WEIGHT		ACRYLIC WINDOW THICKNESS	
			MM	IN	X LENGTH		Y WIDTH		Z HEIGHT		R RADII		X1 LENGTH		Y1 WIDTH		R1 RADII		KG	LB	MM	IN
					MM	IN	MM	IN	MM	IN	MM	IN	MM	IN	MM	IN	MM	IN				
39900030		00	15	9/16	281	11 1/16	281	11 11/16	25	1	72.5	2 7/8	211	8 5/16	211	8 5/16	42.5	1 11/16	1.6	3.5	8	5/16
39903030		03	15	9/16	246	9 11/16	301	11 7/8	25	1	72.5	2 7/8	176	6 15/16	231	9 1/8	42.5	1 11/16	1.6	3.5	8	5/16
39910030	399100303	10	15	9/16	330	13	330	13	25	1	72.5	2 7/8	260	10 1/4	260	10 1/4	42.5	1 11/16	2.2	4.9	8	5/16
39920030		20	15	9/16	272	10 11/16	417	16 7/16	25	1	72.5	2 7/8	202	7 15/16	347	13 11/16	42.5	1 11/16	2.3	5.1	8	5/16
39930030	399300303	30	15	9/16	397	15 5/8	527	20 3/4	25	1	72.5	2 7/8	327	12 7/8	457	18	42.5	1 11/16	4.2	9.3	8	5/16
39940030	399400303	40	15	9/16	491	19 5/16	491	19 5/16	25	1	72.5	2 7/8	421	16 9/16	421	16 9/16	42.5	1 11/16	4.6	10.1	8	5/16
39941030		41	15	9/16	246	9 11/16	491	19 5/16	25	1	72.5	2 7/8	176	6 15/16	421	16 9/16	42.5	1 11/16	2.5	5.5	8	5/16
39944030	399440303	44	15	9/16	512	20 3/16	512	20 3/16	25	1	72.5	2 7/8	442	17 3/8	442	17 3/8	42.5	1 11/16	4.8	10.6	8	5/16
39950030	399500303	50	15	9/16	447	17 5/8	577	22 11/16	25	1	72.5	2 7/8	377	14 13/16	507	19 15/16	42.5	1 11/16	4.8	10.6	8	5/16
39954030	399540303	54	15	9/16	462	18 3/16	577	22 11/16	25	1	72.5	2 7/8	392	15 7/16	507	19 15/16	42.5	1 11/16	4.9	10.8	8	5/16
39960030	399600303	60	15	9/16	577	22 11/16	577	22 11/16	25	1	72.5	2 7/8	507	19 15/16	507	19 15/16	42.5	1 11/16	6.4	14.1	10	3/8
39965030		65	15	9/16	560	22 11/16	560 MIN 675 MAX	22 11/16 26 9/16	25	1	72.5	2 7/8	SEE DRAWING ABOVE				42.5	1 11/16	6.5	14.3	10	3/8





### Low Profile Round Hatch Dimensions & Cut-out

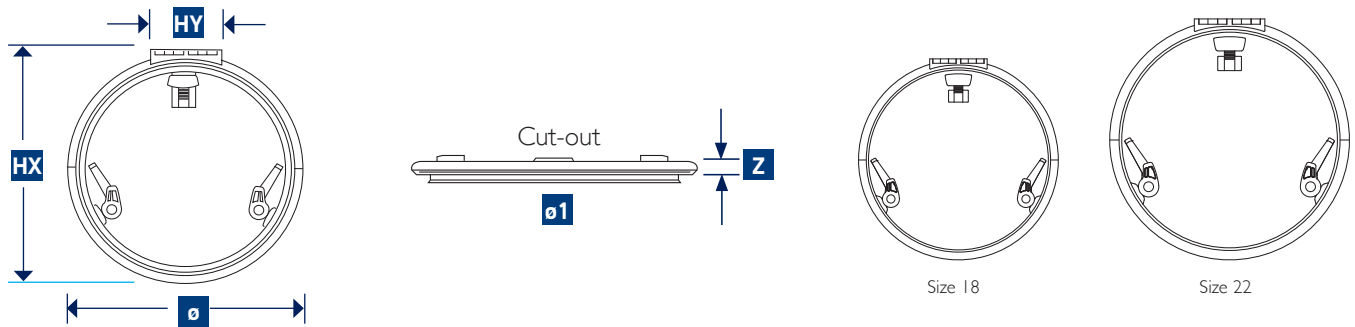

PART NUMBER	SIZE	LOWER FRAME FLANGE		OVERALL DIMENSIONS								CUT-OUT DIMENSIONS Change if Trimkits are used				HATCH WEIGHT		ACRYLIC WINDOW THICKNESS	
		MM	IN	Ø DIAMETER		Z HEIGHT		HX HINGE LENGTH		HY HINGE WIDTH		Ø1 DIAMETER		KG	LB	MM	IN		
				MM	IN	MM	IN	MM	IN	MM	IN	MM	IN						
39918030	18	15	9/16	490	19 15/16	25	1	493	19 7/16	141	5 9/16	420	16 9/16	3.8	8.4	8	5/16		
39922030	22	15	9/16	588	23 1/8	25	1	591	23 1/4	173	6 13/16	518	20 3/8	5.8	12.8	10	3/8		

### Low Profile D-Hatch Dimensions & Cut-out

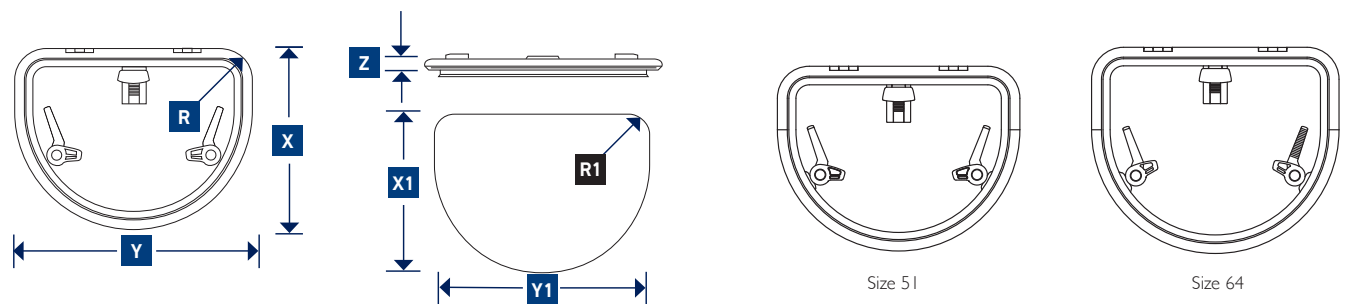

PART NUMBER	SIZE	LOWER FRAME FLANGE		OVERALL DIMENSIONS								CUT-OUT DIMENSIONS Change if Trimkits are used						HATCH WEIGHT		ACRYLIC WINDOW THICKNESS	
		MM	IN	X LENGTH		Y WIDTH		Z HEIGHT		R RADII		X1 LENGTH		Y1 WIDTH		R1 RADII		KG	LB	MM	IN
				MM	IN	MM	IN	MM	IN	MM	IN	MM	IN	MM	IN	MM	IN				
39951030	51	15	9/16	448	17 5/8	588	23 1/8	25	1	72.5	2 7/8	378	14 7/8	518	20 3/8	42.5	1 11/16	5.5	12.1	8	5/16
30067300	64	15	9/16	500	19 11/16	600	23 5/8	25	1	72.5	2 7/8	430	16 15/16	530	20 7/8	42.5	1 11/16	6.4	14.1	8	5/16

## 4. Hatch & Portlight



### Medium Profile Hatch

Ideal as a foredeck hatch on larger offshore yachts, the Medium Profile has thicker acrylic and deeper frame sections for greater strength and durability. It features Lewmar's unique sealing system, allowing for easy acrylic replacement. The Medium Profile Hatch blends ruggedness with the smooth, modern lines of the Low Profile Hatch.

- Outside handles allow the hatch to be opened from on deck if it is not locked
- Friction levers hold the lid open in any position up to 95°
- Anodised aluminium frame for corrosion resistance
- Curved upper frame profile for strength as well as modern styling
- Full range of spare parts available on-line [www.lewmar.com](http://www.lewmar.com)

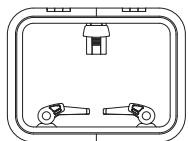

Size 30

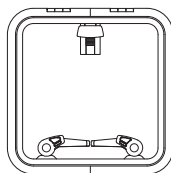

Size 40

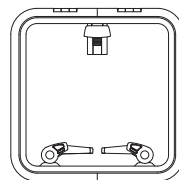

Size 44\*

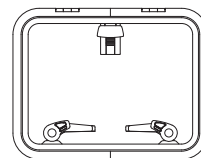

Size 50

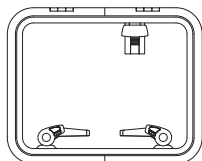

Size 54\*

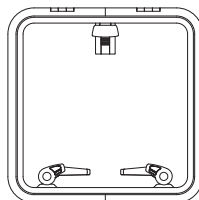

Size 60

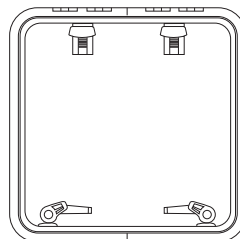

Size 70

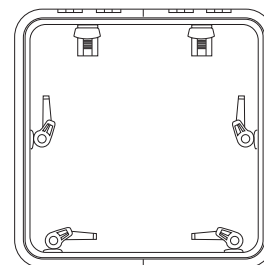

Size 77



\* Minimum size for ISO 9094 escape hatches

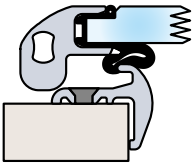

### Medium Profile Hatch Standard Specifications

- Grey mouldings
- Acrylic colours grey, clear or white
- Size 30 - 65 supplied with friction hinges as standard
- Simple and easy maintenance

### Medium Profile Hatch Dimensions

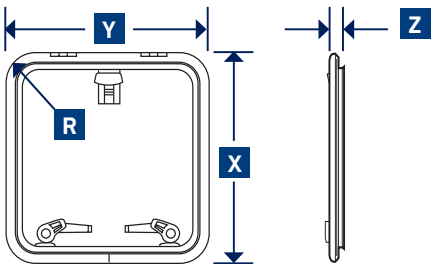

### Medium Profile Hatch Cut-out

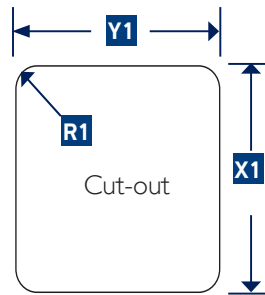

PART NUMBER	SIZE	LOWER FRAME FLANGE		OVERALL DIMENSIONS						CUT-OUT DIMENSIONS CHANGE IF TRIMKITS ARE USED						HATCH WEIGHT		ACRYLIC WINDOW THICKNESS			
		MM	IN	X LENGTH		Y WIDTH		Z HEIGHT		R RADI		X1 LENGTH		Y1 WIDTH		R1 RADI	KG	LB	MM	IN	
39930020	30	15	9/16	398	15 5/8	528	20 3/4	32	1 1/4	78	3 1/16	327	12 7/8	457	18	42.5	1 11/16	5	11.1	12	1/2
39940020	40	15	9/16	492	19 3/8	492	19 3/8	32	1 1/4	78	3 1/16	421	16 9/16	421	16 9/16	42.5	1 11/16	5.9	13	12	1/2
39944020	44	15	9/16	513	20 3/16	513	20 3/16	32	1 1/4	78	3 1/16	442	17 3/8	442	17 3/8	42.5	1 11/16	6.4	14.1	12	1/2
39950020	50	15	9/16	448	17 5/8	578	22 3/4	32	1 1/4	78	3 1/16	377	14 13/16	507	19 15/16	42.5	1 11/16	6.3	13.9	12	1/2
39954020	54	15	9/16	463	18 1/4	578	22 3/4	32	1 1/4	78	3 1/16	392	15 7/16	507	19 15/16	42.5	1 11/16	6.5	14.3	12	1/2
39960020	60	15	9/16	578	22 3/4	578	22 3/4	32	1 1/4	78	3 1/16	507	19 15/16	507	19 15/16	42.5	1 11/16	7.8	17.2	12	1/2
39970020	70	15	9/16	698	27 1/2	698	27 1/2	32	1 1/4	78	3 1/16	627	24 11/16	627	24 11/16	42.5	1 11/16	10.6	23.4	12	1/2
39977020	77	15	9/16	770	30 5/16	770	30 5/16	32	1 1/4	78	3 1/16	699	27 1/2	699	27 1/2	42.5	1 11/16	12.7	28	12	1/2

## 4. Hatch & Portlight



### Ocean Hatch

With its classic style, the Ocean Hatch is fitted to many offshore cruising boats around the world. Its rugged construction provides the ultimate protection against the elements, whatever conditions you might face. Available with flat base or flange base.

- Friction levers hold the lid open in any position up to 95°
- Anodised aluminium frame for corrosion resistance
- Full range of spare parts available on-line [www.lewmar.com](http://www.lewmar.com)



Size 10



Size 20

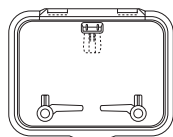

Size 30

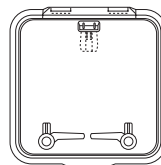

Size 40

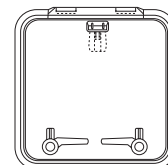

Size 44\*

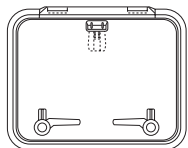

Size 50

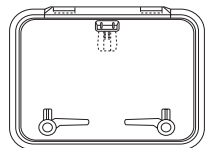

Size 54

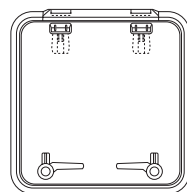

Size 60

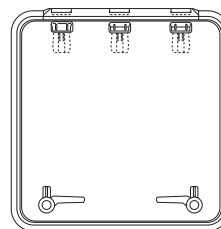

Size 70

**CE**  
Approved

ALL SIZES  
AREA 2A.  
SEE PAGE 132

\* Minimum size for ISO  
9094 escape hatches

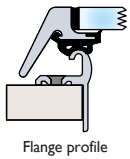

Flange profile

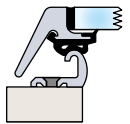

Flat Base profile

### Ocean Hatch Standard Specifications

- Grey mouldings
- Acrylic colour: grey
- Size 30 - 65 supplied with friction hinges as standard
- Simple and easy maintenance

### Ocean Hatch Dimensions

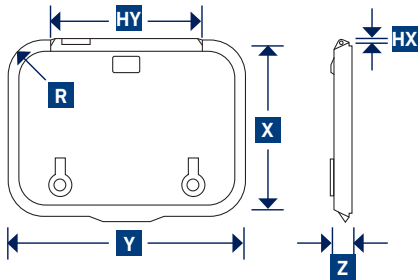

### Ocean Hatch Cut-out

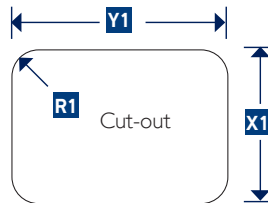

PART NUMBER	SIZE	LOWER FRAME	OVERALL DIMENSIONS										CUT-OUT DIMENSIONS Change if Trimkits are used						HATCH WEIGHT		ACRYLIC WINDOW THICKNESS			
			X		Y		Z		R		HX		HY		X1		Y1						R1	
			MM	IN	MM	IN	MM	IN	MM	IN	MM	IN	MM	IN	MM	IN	MM	IN	MM	IN	MM	IN	KG	LB
39610050	10	FLAT BASE FLANGE	324	12 3/4	324	12 3/4	39.5	1 9/16	75	2 15/16	5	3/16	138	5 7/16	255	10 1/16	255	10 1/16	40	1 9/16	2.26	5.77	10	3/8
39610070	10	FLAT BASE FLANGE	266	10 1/2	411	16 3/16	39.5	1 9/16	69	2 11/16	5	3/16	225	8 7/8	197	7 3/4	342	13 7/16	34	1 5/16	2.74	6.04	10	3/8
39620050	20	FLAT BASE FLANGE	391	15 3/8	521	20 1/2	39.5	1 9/16	75	2 15/16	5	3/16	335	13 3/16	322	12 11/16	452	17 13/16	40	1 9/16	4.5	9.9	10	3/8
39620070	20	FLAT BASE FLANGE	266	10 1/2	411	16 3/16	39.5	1 9/16	69	2 11/16	5	3/16	225	8 7/8	327	12 7/8	457	18	42.5	1 11/16	2.74	6.04	10	3/8
39640050	40	FLAT BASE FLANGE	485	19 1/8	485	19 1/8	39.5	1 9/16	75	2 15/16	5	3/16	299	11 3/4	416	16 3/8	416	16 3/8	40	1 9/16	4.76	10.5	10	3/8
39640070	40	FLAT BASE FLANGE	485	19 1/8	485	19 1/8	39.5	1 9/16	75	2 15/16	5	3/16	299	11 3/4	421	16 9/16	421	16 9/16	42.5	1 11/16	4.76	10.5	10	3/8
39644050	44	FLAT BASE FLANGE	509	20 1/16	509	20 1/16	43	1 11/16	76	3	4	3/16	302	11 7/8	437	17 3/16	437	17 3/16	40	1 9/16	5	11	12	1/2
39644070	44	FLAT BASE FLANGE	509	20 1/16	509	20 1/16	43	1 11/16	76	3	4	3/16	302	11 7/8	442	17 3/8	442	17 3/8	42.5	1 11/16	5	11	12	1/2
39650050	50	FLAT BASE FLANGE	444	17 1/2	574	22 5/8	43	1 11/16	76	3	4	3/16	367	14 7/16	372	14 5/8	502	19 3/4	40	1 9/16	7.3	16.1	12	1/2
39650070	50	FLAT BASE FLANGE	444	17 1/2	574	22 5/8	43	1 11/16	76	3	4	3/16	367	14 7/16	377	14 13/16	507	19 15/16	42.5	1 11/16	7.3	16.1	12	1/2
39654050	54	FLAT BASE FLANGE	459	18 1/16	574	22 5/8	43	1 11/16	76	3	4	3/16	367	14 7/16	387	15 1/4	502	19 3/4	40	1 9/16	7.6	16.7	12	1/2
39654070	54	FLAT BASE FLANGE	459	18 1/16	574	22 5/8	43	1 11/16	76	3	4	3/16	367	14 7/16	392	15 7/16	507	19 15/16	42.5	1 11/16	7.6	16.7	12	1/2
39660050	60	FLAT BASE FLANGE	574	22 5/8	574	22 5/8	43	1 11/16	76	3	4	3/16	367	14 7/16	502	19 3/4	502	19 3/4	40	1 9/16	8	17.6	12	1/2
39660070	60	FLAT BASE FLANGE	574	22 5/8	574	22 5/8	43	1 11/16	76	3	4	3/16	367	14 7/16	507	19 15/16	507	19 15/16	42.5	1 11/16	8	17.6	12	1/2
39670050	70	FLAT BASE FLANGE	694	27 5/16	694	27 5/16	43	1 11/16	76	3	4	3/16	487	19 3/16	622	24 1/2	622	24 1/2	40	1 9/16	10.8	23.8	12	1/2
39670070	70	FLAT BASE FLANGE	694	27 5/16	694	27 5/16	43	1 11/16	76	3	4	3/16	487	19 3/16	627	24 11/16	627	24 11/16	42.5	1 11/16	10.8	23.8	12	1/2

## 4. Hatch & Portlight



### Stainless Steel Hatch

Using Lewmar's proven hatch technology, Lewmar are now able to offer stainless steel deck hatches. The stainless hatch complements and matches other stainless fittings on a high specification deck.

The hatches have a similar profile to the highly successful Medium Profile Hatch and are directly interchangeable. This flexibility allows boat builders to tailor deck specification to individual customer requirements without retooling.

- High-polished stainless steel upper frame and hinges
- High-polished stainless or black fittings
- CE approved Area 2A
- Gas struts available as an option
- White lower frame



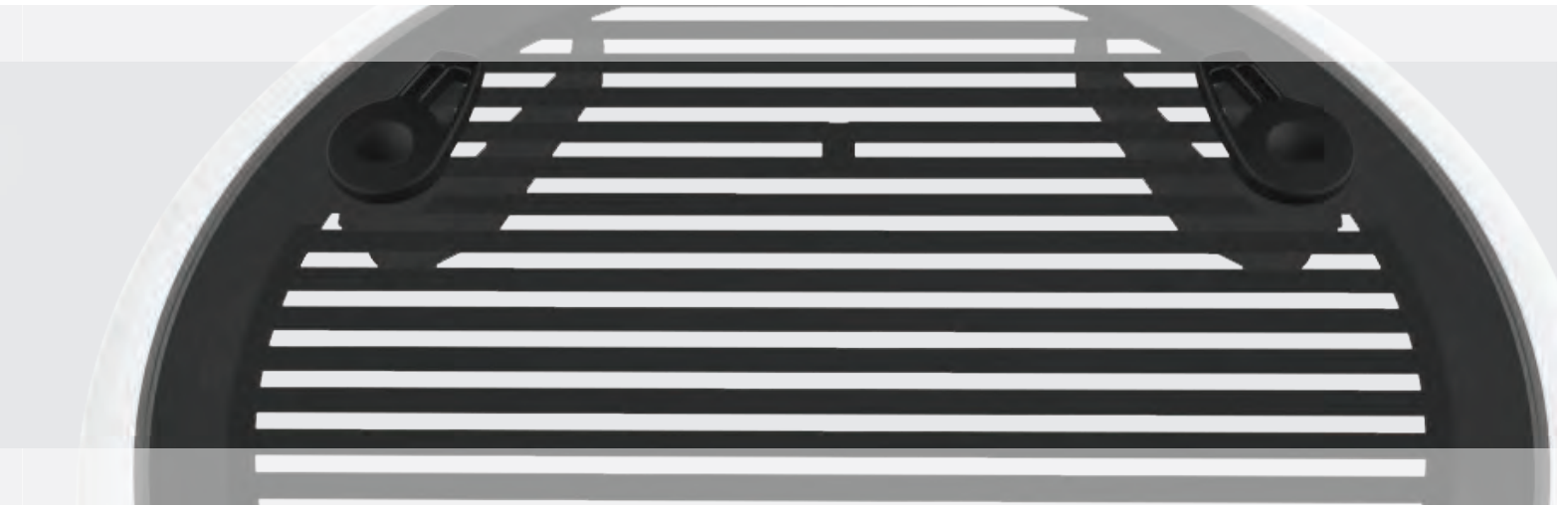

## Integral Privacy Blind

The Lewmar Integral Privacy Blind provides a low-cost blind solution.

The blind is permanently installed under the hatch lens. When the shutter is open a pattern of stripes across the lens provides a moderate level of privacy. When the slider is operated, the lens is completely obscured to ensure that no one can see into the cabin. This system is ideal for cabins and heads compartments where there is no room to fit a Roller Shade.

The Integral Privacy Blind can be specified on any Lewmar hatch to suit an OEM's specific requirements.

- Clean aesthetics
- Simple operation with effective blackout



## 4. Hatch & Portlight



### Pilot Hatch

The Pilot Hatch is designed for use on the wheelhouse or cockpit canopy of a power craft, and the styling complements the Low Profile and Medium Profile Hatch Ranges.

- Opens up enclosed steering positions
- Sliding technology from Lewmar's hardware track systems, ensuring minimum friction
- The Pilot Hatch uses Lewmar's unique seal system for improved sealing and easy servicing
- Operated with a single handlebar that rotates to seal down the hatch
- Can be secured with a 5cm opening when full ventilation is not required

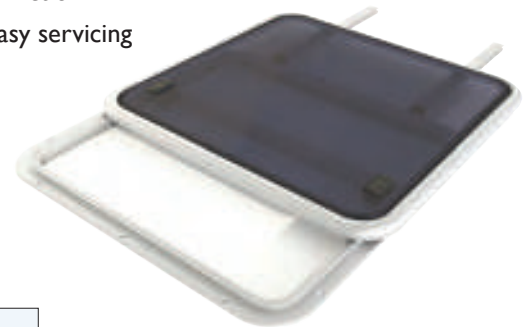

Pilot Hatch Dimensions

Cut-out Dimensions

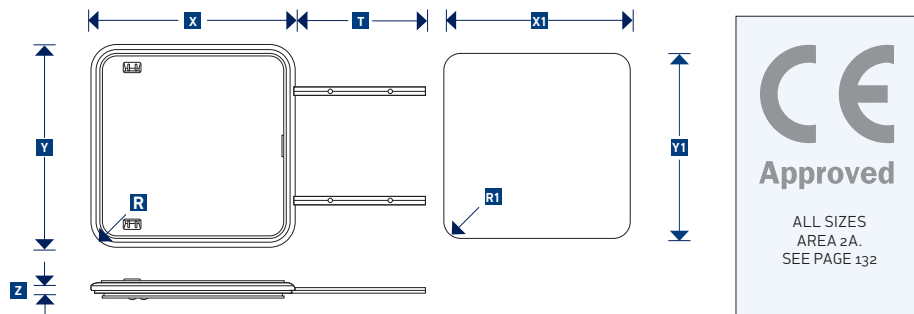

PART NUMBER	SIZE	ACRYLIC COLOUR/TINT	LOWER FRAME FLANGE		OVERALL DIMENSIONS						CUT-OUT DIMENSIONS Change if Trimkits are used						ACRYLIC WINDOW THICKNESS					
			MM	IN	X WIDTH		Y LENGTH		Z HEIGHT		R RADII		T TRACK LENGTH		X1 WIDTH		Y1 LENGTH		R1 RADII		MM	IN
30211300	40	SMOKE GREY	15	9/16	495	19 1/2	491	19 5/16	29	1 1/8	73	2 7/8	284	11 3/16	421	16 9/16	421	16 9/16	42.5	1 11/16	8	5/16
30074000	60	SMOKE GREY	15	9/16	581	22 7/8	577	22 11/16	29	1 1/8	73	2 7/8	373	14 2/3	507	19 15/16	507	19 15/16	42.5	1 11/16	10	3/8
30229100	70	SMOKE GREY	15	9/16	701	27 5/8	697	27 7/16	29	1 1/8	73	2 7/8	486	19 1/8	627	24 11/16	627	24 11/16	42.5	1 11/16	10	3/8
30069900	78	SMOKE GREY	15	9/16	844	33 1/4	790	31 1/8	29	1 1/8	73	2 7/8	638	25 1/8	770	30 5/16	720	28 1/4	42.5	1 11/16	10	3/8

Trim Kits are not available for size 78, normal Trim Kit fits size 40, 60 and 70.

Hatches should be fitted to a flat surface with a maximum tolerance of  $\pm 1$ mm.

The Pilot Hatch is only for use on wheel houses and cockpit canopies. It is not suitable for use on normal decks and coachroof applications. Fastening size for lower frame and sliding track use 5mm CSK screws No. 10 UNC 2BA

The pilot hatch cannot be operated from the outside.





## Powered Pilot Hatch

Following market demands for more sophisticated systems, Lewmar have used their considerable design experience to create an innovative powered pilot hatch for simple ventilation control.

Effortless operation is achieved through a range of switching options. The full mechanism and railings are contained within the aperture of the hatch and the above-deck profile is only 35mm, ensuring the visual impact is minimal.

Lewmar have developed a truly premium product, blending effortless utility with stunning design.

- Compact mechanism utilises spiral cables for smooth operation
- Load sensing closure provides protection from entrapment
- Can be retrofitted to same aperture as the standard pilot hatch
- Can be held in any position to allow varying degrees of ventilation
- Available in Grey or Dark Grey acrylic
- Frame finishes include Matte clear anodized, Bright clear anodized, Black powder coat, White powder coat
- Custom sizes available on request
- 12V or 24V Options available



BASE PART NUMBER	SIZE	ACRYLIC COLOUR/TINT	UPPER/LOWER FRAME FINISH	POWER 12/24V	OVERALL DIMENSIONS												CUT-OUT DIMENSIONS Change if Trimkits are used						ACRYLIC WINDOW THICKNESS	
					X WIDTH		Y LENGTH		Z HEIGHT		R RADII		T TRACK LENGTH		X1 WIDTH		Y1 LENGTH		R1 RADII					
					MM	IN	MM	IN	MM	IN	MM	IN	MM	IN	MM	IN	MM	IN	MM	IN	MM	IN		
30320600	60				45	1 3/4	581	22 7/8	577	22 11/16	29	1 1/8	73	2 7/8	373	14 2/3	510	20	510	20	42.5	1 2/3	10	3/8
30307400	70		CONTACT YOUR LEWMAR REPRESENTATIVE		45	1 3/4	701	27 5/8	697	27 7/16	29	1 1/8	73	2 7/8	486	19 1/8	630	24 3/4	630	24 3/4	42.5	1 2/3	10	3/8
30307500	78				45	1 3/4	844	33 1/4	790	31 1/8	29	1 1/8	73	2 7/8	638	25 1/8	773	30 7/16	723	28 1/2	42.5	1 2/3	10	3/8

## 4. Hatch & Portlight



### Flybridge Hatch

Lewmar's flybridge hatches offer a safe and attractive way of accessing to the helm station on flybridge vessels.

Lewmar can customise the shape and size to match OEM requirements. They can be built around the low profile, medium profile or flush hatch platforms.

As with other products acrylic colour, frame finish, lid-support mechanisms etc can be customised to suit.

Contact your Lewmar representative for further information.

- **Elegant access point to different levels**
- **Available in range of finishes: powder-coated aluminium, stainless steel or frameless**
- **Powered option offers hands-free operation**
- **Radius or Mitre corners available**



The flybridge hatches are intended for use between two wet areas. Therefore ISO 12216 certification is not required.



## Powered Hatches

In response to shifting design priorities, Lewmar has designed a powered hatch platform for a range of installation possibilities.

Powered hatches are ideal for areas that are difficult to reach by hand, or for hatches too heavy for easy manual operation. Activated at the touch of a button, the smooth opening action is powered by durable, marinised actuators. Internal sensors prevent over-opening and ensure uncompromised seal compression.

Contact your Lewmar representative to discuss our bespoke design process.

- Clean aesthetics based on our proven hatch platforms
- Durable components
- Available in a range of finishes and sizes, custom specified
- Smooth and stable operation



## 4. Hatch & Portlight



### Powerboat Hatch

The Lewmar power boat hatch is a premium product; customisable to suit individual tastes and finished to the highest standards.

316 stainless fittings and polished bevelled edges exude quality and the painted acrylic hides the seal, framework and deck fixings from view.

- Clean aesthetics
- EPDM seal and gas struts provide high-quality operation
- A range of exterior styling options available
- Painted acrylic to hide seal, lower frame and fixings
- A selection of handle variations available from plastic to stainless steel
- Highly polished bevelled edge to give a premium finish
- Stainless hinges available
- Flexible length and strength options





## Washboard Hatch

Lewmar's washboard hatch offers a complete turnkey solution to boat-builders who have traditionally fabricated their own washboard solutions in-house.

Lewmar's solution is highly flexible; as long as the sides of the companionway are parallel, Lewmar can produce a washboard to suit.

- Lockable from inside and out
- Simple one-handed operation
- Sprung panels
- Choice of 1 or 2 acrylic panels
- Choice of acrylic colour
- Optional air vents
- Comes with hard anodised side runners

Contact your Lewmar representative for more information.



## 4. Hatch & Portlight



### Access Doors

Building on 50 years of hatch design, Lewmar are constantly developing platforms to offer more onboard solutions. The introduction of watertight doors in various applications is a display of our continued commitment to boat management and safety.

#### Crew Door

Developed as a discreet solution for concealing crew accommodation, the crew door concept provides a robust closure without interrupting sleek transom lines.

- Locking handles ensure high seal compression
- Available with white or stainless furniture
- Integrated privacy shutter allows enhanced crew concealment
- Sturdy aluminium construction powder-coated to customer specification

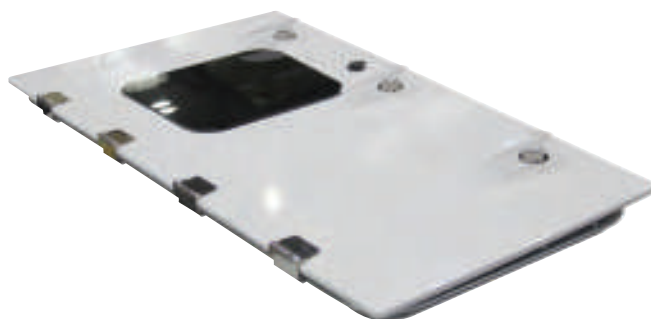

#### Companionway Door

Lewmar strive to identify solutions that follow market trends. The companionway door is a powerboat-focussed solution that combines elegance with functionality to generate unmatched attention to customer desires.



- Custom-shaped acrylic to customer specification, encouraging innovative design concepts
- Flexible solution to a host of varying design scenarios
- Based on proven hatch and hardware platforms
- Secure and watertight entry point to saloon



## Soft Roofs and Sun Canopies

In recent years solar shading and sliding roof systems have significantly increased in popularity. Utilising proprietary aluminium extrusions Lewmar is able to offer a range of soft roofs and canopies to match the OEMs specific requirements.

Our sliding roofs are built on the backbone of Lewmar's proven hardware range and are available in both manual and powered options. They can be supplied complete with fabric ready for installation or the OEM can fit their own choice of fabric.

Lewmar's folding arm sun canopies are custom-sized to suit the boat's requirements. Available in stainless steel or aluminium and powered for ease of use. As with our sliding roofs, the fabric can be supplied with the roof or can be customer-sourced. Remote control is available as an option.

- **Soft canvas retractable roof**
- **Can be scaled/sized to fit most boats**
- **Manual and motorised version is available**
- **Roof can be locked in various open positions, which are customisable**
- **Main beams have individual tensioning system to ensure canvas is taut over length and width**
- **Canvas locking system allows for easy canvas removal for maintenance**



## 4. Hatch & Portlight

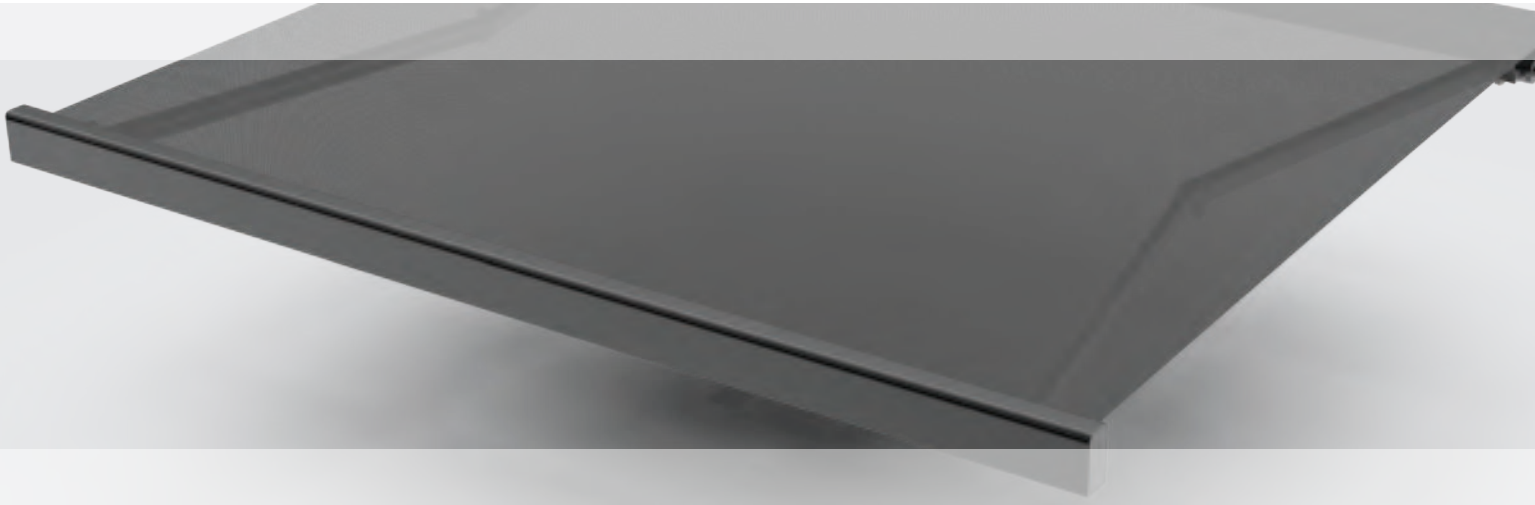

### Aft Retracting Sun Canopy

A recent addition to the Lewmar range, the electric retractable canopy offers a sleek sunshade, most commonly used in aft areas while not under way.

Built from stylish oval stainless steel tubing and investment-cast end fittings, the canopy can be deployed via its single electric motor at the touch of a button. Gas springs within the folding arms keep the canopy under constant tension at various stages of deployment.

An aluminium valance is available in a custom range of colours, providing a seamless finish to the superstructure when in the fully stowed position.

- Soft canvas or mesh fabric
- 316 Stainless Construction
- 12V or 24V Power Options
- Simple installation and fabric replacement
- A built-in mechanism allows for height adjustment post installation
- Carbon or Stainless Steel poles for supports whilst underway
- Custom sizes upon request
- Valances can be custom formed to suit superstructure





# Hatch Accessories

## ABS Plastic Trim and Flyscreen

- Easy and stylish way of finishing a hatch installation inside the cabin
- Trim kits come complete with a flyscreen
- Can only be fitted to boats with a headlining
- Will fit all standard hatches featured in this catalogue except flat base Ocean Hatches or unless otherwise stated



## Cut Out Dimensions and Deck Thickness Requirements

CUT OUT DIMENSION INCREASE <sup>1</sup>	ADD 4MM TO X1 @ Y1 AND 2MM TO R1
OCEAN	MIN HULL THICKNESS = 25MM MAX HULL THICKNESS = 72MM
FLUSH HATCH / LOW AND MEDIUM PROFILE	MIN HULL THICKNESS = 15MM MAX HULL THICKNESS = 62MM

<sup>1</sup> Cut Out dimensions for hatches are shown on their relevant pages

PART NUMBER	HATCH SIZE	PART NUMBER	HATCH SIZE	PART NUMBER	HATCH SIZE
367400252	00 <sup>2</sup>	367622252	22 ROUND	367651252	51
367403252	03	367630252	30	367654252	54
367410252	10	367640252	40	367660252	60
367618252	18 ROUND	367441252	41	367665252	65
367420252	20 <sup>2</sup>	367644252	44	367670252	70
367620252	20 OCEAN	367650252	50		

<sup>2</sup> Does not fit Ocean, Rollstop or Superhatch

## Telescopic Stay

- Features excellent lid positioning and rigid control
- Allows hatch opening up to 95°
- An advantage on smaller to mid size yachts where deck space is at a premium

Grey 360918999 Black 360918992



## Retro-Fit Vent

- Vent can be fitted to the acrylic lens of any Lewmar hatch or to the deck
- Made from the same rugged composite used in many Lewmar hatch and winch parts
- Styled to match the Low and Medium Profile hatches
- Captive bung to close the ventilator – it cannot be lost
- Fits deck thickness to 100mm
- Tested to CE ISO 12216 and leak tested
- No sealant required for hatch fitting

Grey: 361041990 Mini Grey: 361899990  
Black: 361041992 Mini Black: 361899991



## Retro-Fit Lock and Key Kit

- Can be fitted to any Lewmar Hatch by drilling a hole through the acrylic and riveting a catch block to the lower frame
- Lock and key are marinised to prevent corrosion

Part No 360259990



## Flyscreen Hinge

- Makes it easier to access the handles when the flyscreen is in place
- Only necessary to undo two tabs and the flyscreen will hinge down – and not fall out
- Flyscreen can be removed and stowed separately if required
- Hinges are also available as retro fit items
- Kit includes all tabs, screws, screw cap etc.

White: 361196992



# 4. Hatch & Portlight Hatch Spares

## Hinge Caps



PART NO	KIT
361027999	LOW AND MEDIUM PROFILE HINGE CAP X 10
361044999	LOW AND MEDIUM PROFILE HINGE CAP X 100

## Catch Block



PART NO	KIT
360924990	LOW AND MEDIUM PROFILE SPARE (GREY)
360924992	LOW AND MEDIUM PROFILE SPARE (BLACK)
360060990	OCEAN CATCH BLOCK SPARE

## Straight Joint Inserts



PART NO	KIT
360925999	UPPER FRAME JOINT INSERT (STRAIGHT)

## Round Joint Inserts



PART NO	KIT
360926999	UPPER FRAME JOINT INSERT (ROUND)

## Handle kits



PART NO	KIT
361680990	LP / MP / OCEAN HANDLE KIT GREY
36168099*	LP / MP / OCEAN HANDLE KIT BLACK
361680992	FLUSH 2G / 3G HANDLE KIT BLACK
36168099*	FLUSH 2G / 3G HANDLE KIT GREY
360255990	SMALL LH HANDLE KIT GREY
360255992	SMALL LH HANDLE KIT BLACK
360256990	SMALL RH HANDLE KIT GREY
360256992	SMALL RH HANDLE KIT BLACK

## Outside Handles



PART NO	KIT
360919990	LP / MP EXTERNAL HANDLE GREY X 5
360919992	LP / MP EXTERNAL HANDLE BLACK X 5

## LP/MP Hatch Hinge Kit (Friction)



PART NO	KIT
361263999	LP / MP MK2 ALLOY LID HINGE KIT

## Friction Lever



PART NO	KIT
360917990	LP / MP GREY F-LEVER SPARE
360271990	OCEAN 00-20 GREY F-LEVER SPARE
360272990	OCEAN 30-40 / CL30-60 F-LEVER SPARE
360273990	OCEAN 50 / CL65+ F-LEVER SPARE

## Friction Lever Gaskets



PART NO	KIT
361206999	GASKET - SMALL F-LEVER X 20
361207999	GASKET - LARGE F-LEVER X 20

Low Profile Seal



PART NO	LOW PROFILE HATCH SIZE
360860999	00
360861999	03
360862999	05
360863999	10
360864999	20
360865999	21
360866999	30
360867999	40
360868999	41
360869999	44
360870999	50
360871999	54
360872999	60
360873999	61
360874999	65 (TRAPEZOID)
360875999	18 (ROUND)
360876999	22 (ROUND)

Medium Profile Seal



PART NO	MEDIUM PROFILE HATCH SIZE
360959999	30
360960999	40
360961999	44
360962999	50
360963999	54
360964999	60
360965999	66
360966999	70
360968999	77

Vent Seal

PART NO	DESCRIPTION
361446999	VENT SEALS KIT

Ocean Hatch Seal



PART NO	OCEAN HATCH SIZE
360370999	00
360371999	10
360372999	20
360373999	30
360374999	40
360381999	44
360375999	50
360382999	54
360376999	60
360377999	63
360378999	65
360379999	70
360380999	75
360383999	77

Flush Hatch 1G/2G Seal

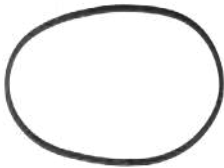

PART NO	FLUSH HATCH SIZE
361590999	10
361597999	20
361598999	30
361591999	44
361592999	60
361592999	70
361594999	18 (ROUND)
361595999	22 (ROUND)
361596999	27 (ROUND)

Low Profile Acrylic

For Mk2 (post-2000) hatches with friction lever



PART NO	SIZE
361050900	00
361051900	03
361052900	10
361053900	20
361054900	21
361055900	30
361056900	40
361057900	41
361058900	44
361059900	50
361060900	54
361061900	60
361062900	61
361063900	65 (TRAPEZOID)
361064900	18 (ROUND)
361065900	22 (ROUND)

Medium Profile Acrylic

For hatches with friction lever



PART NO	SIZE
361130900	30
361131900	40
361132900	44
361133900	50
361134900	54
361135900	60
361136900	70
361137900	77

Misc. Flush Hatch 3G Spares

PART NO	KIT
360918299	F3G STAY TOP CAP KIT BLACK
361894999	F3G STAY UPPER HINGE KIT

# 4. Hatch & Portlight

## How to identify your Lewmar hatch

Spares are specific to certain ranges of hatch, so identification is essential for ensuring correct parts are used. Hatches produced after October 1997 have information stamped in the acrylic which will identify them - please quote this when ordering spares.

IDENTIFYING FEATURES	SUPERHATCH	ROLLSTOP	TRIMLINE	COASTLINE & TRANSPORT	OCEAN	CONCEPT	LOW PROFILE	MEDIUM PROFILE
PRODUCTION DATES	1980-87	1986-92	1988-99	1991-99	1991 - NOW	1994-00	1998 - NOW	1999 - NOW
HEIGHT ABOVE DECK (MM)	50	39-42	21	21	40-43	19	25	32
LID IS HELD OPEN BY A STAY		*	EARLY MODELS				RETROFIT OPTION	RETROFIT OPTION
ACRYLIC NOT BONDED INTO AN ALLOY FRAME						*	*	*
AS THE LID IS LIFTED, IT CLICKS THROUGH A SERIES OF POSITIONS AT WHICH THE HATCH WILL HOLD OPEN	*	*						
CATCH BLOCKS IN CORNERS OF THE LOWER FRAME	*							
LARGE INSIDE HANDLES HAVE RED OR GREY LOCKING BUTTONS INSIDE HANDLE		*	*	*	*		*	*
HINGE HAS A BLACK METAL STRAP EXTENDING A SHORT WAY OVER THE ACRYLIC.	*							

### Superhatch

- Produced 1980 - 1987.
- Catch blocks in corners of the lower frame
- Spares no longer available



### Rollstop

- Produced 1986 - 1992.
- Red locking button in larger handles
- Spares no longer available



### Trimline

- Produced 1988-1999
- Red locking button in larger handles
- Fastenings inside lip
- Metal sliding stay
- Seals and handles available as spares.



### Coastline

- Produced 1991 - 1999
- Locking button in larger handles
- Fastenings inside lip
- Friction lever
- Seals, friction lever and handles available as spares



### Ocean Hatch

- Produces 1991 - now
- Locking button in larger handles
- Inverted "J" profile lower frame
- Friction lever
- High profile lid
- Full range of spares available



### Low Profile Hatch

- Produced 1998 - now
- Replaceable acrylic panel
- Small handles bonded on
- Mark 1 and Mark 2
- Quote acrylic marking when ordering spares



### Medium Profile Hatch

- Produced 1999 - now
- Replaceable acrylic panel
- Mark 1 and Mark 2



### Flush 2G

- Produces 2006 - now
- Painted acrylic lid
- Seal attached to acrylic
- Full range of spares available
- Quote acrylic marking when ordering spares



### Flush 3G

- Produced 2010 - now
- Seal attached to lower frame
- Full range of spares available
- Quote acrylic marking when ordering spares



## How to find your lens code

All Lewmar hatches and portlights (except old Standard) produced since October 1997 have had identification information stamped on the acrylic. On Portlights and Fixedlights the information is under the LEWMAR branding. On hatches the information is between the right hand handle and the edge of the acrylic.

### Identifying the range name & hatch size

For Hatches: Ocean, Coastline, Trimport, Trimline or Concept

For Portlights: Standard (New Standard only), Atlantic, Ocean or ASTAR (Hallberg Rassy only)

There are three different formats:



On some Lewmar hatches you may need to peel back the seal slightly to reveal the code.

The size is abbreviated as **SZXX**, for example :

SZ60 = Size 60 hatch

For portlights the 2 digits used are the 4th and 5th digits of the part number. The 1st digit denotes the size, the 2nd the configuration. For example:

SZ42 = Size 4 New Standard opening portlight

SZ41 = Size 1 New Standard Fixed light

A number in the form **399SSXR**

**SS** is the hatch size

**X** is the acrylic colour: 0 - grey, 2 - clear, 3 - white, 4 - green, 6 - frosted, 8 - dark grey

**R** is the Range: 3 is Low Profile and 2 is Medium Profile

On Mark 2 Low & Medium Profile hatches the number is preceded by 'A'.

A number in the form **300XXX**. This is the first 6 digits of a hatch or portlight custom product part number.

### Identifying the date of manufacture

This appears at the end of the code, in the form **DDMY** (for example 11J7) where the letter code for the month is:

A - January

B - February

C - March

D - April

E - May

F - June

G - July

H - August

J - September

K - October

L - November

M - December

The letter I "India" is not used

There are some features that the coding does not identify. For example:

- Frame finish / colour
- Friction Lever or power boat Stay
- If accessories such as Lock & Key Kit and Vent are fitted

This information, and an acrylic code identifier, are available at [lewmar.com/find-my-hatch](http://lewmar.com/find-my-hatch)



# The Lewmar Portlight Range



## Page 168 Flush Mitre Portlight

- Number of textures, angles and levels is minimised in order to minimise the visual impact of the portlight on the boat
- Acrylic almost flush with the mounting surface
- 12mm acrylic is used in order to achieve the flush effect
- Flat outer frame
- Outer frame powder-coated black to camouflage with the acrylic lens



## Page 170 Stainless Steel Portlight

- Polished stainless outer frame with no joint
- Handles and hinges are fitted to the edge of the lens to allow clear visibility
- ABS plastic inside trim can be cut to length
- Friction hinges hold the window open



## Page 172 Standard Portlight

- The Standard Portlight is fitted to thousands of boats throughout the world
- Aluminium external frame
- Handles and hinges are fitted to the edge of the lens to allow clear visibility
- Quick-action handles
- ABS plastic inside trim can be cut to length
- Friction hinges hold the window open



## Page 174 Atlantic Portlight

- Stronger aluminium outer frame with single welded joint
- Lens bonded into alloy frame for additional stiffness
- Stainless 316 handles
- Aluminium inside trim
- Small opening sizes (10,30 & 32) CE Approved for in-hull installation
- Friction hinges hold the window open



## Page 176 Custom Portlight Solutions

- Concept 3 Portlight - Designed to be installed into larger expanses of acrylic. A ventilation solution that does not compromise aesthetics
- Trimports - Flush lines and large apertures. An almost limitless solution for coachroof design



## Page 178 Portlight Spares and Accessories

- Flyscreens
- Spare acrylics, hinges, handles etc.
- Portlight Identification Guide



## Page 180 Shades

- A selection of flyscreen and blackout shade solutions
- Surface-mounted and flush solutions available
- Easy installation and operation

## 4. Hatch & Portlight



### Flush Mitre Portlight

Complementing the styling of the Lewmar Flush Hatch, the Flush Mitre Portlight offers a seamless line from the hull across the portlight. When installed into acrylic, the Flush Mitre Portlight offers a ventilation solution within the illusion of a larger opening.

- Development of Lewmar Standard Portlight
- Flat outer frame powder-coated black for minimal visual impact
- Acrylic almost flush with the mounting surface
- Flyscreen not supplied as standard

Specifications options:

- Handles: clip (standard) / twist (option)
- Acrylic window 12mm (1/2") colour: grey or dark grey
- Frame colour: Powder-coated black

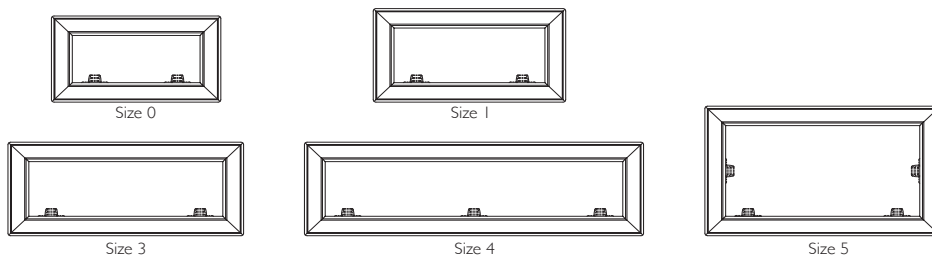

#### Portlight Valance & Fastening Required

HULL THICKNESS	FASTENING	
3.5 TO 6.5 MM	361799999	M5 X 12MM LONG
7 TO 9 MM	361800999 <sup>1</sup>	M5 X 16MM LONG

Standard valance suit hull thickness 3.5 to 9mm. Other valance type available for thicker hull up to 17.5mm. Contact Lewmar for more information

<sup>1</sup> Supplied as standard with portlight listed below  
Fastenings supplied in bags of 100

#### Flush Mitre Portlight Dimensions

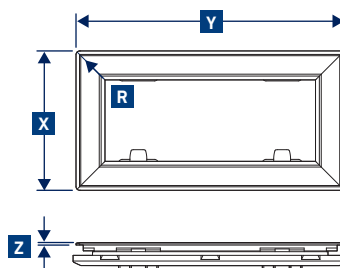

#### Cut-out Dimensions

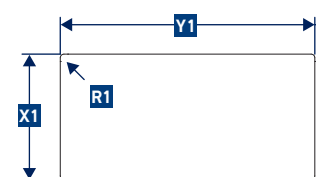





### Flush Mitre Portlight Specifications

PART NUMBER GREY	PART NUMBER DARK GREY	SIZE	OVERALL DIMENSIONS										CUT-OUT DIMENSIONS						PORTLIGHT WEIGHT	
			X WIDTH		Y LENGTH		Z HEIGHT		R RADII		X1 WIDTH		Y1 LENGTH		R1 RADII					
			MM	IN	MM	IN	MM	IN	MM	IN	MM	IN	MM	IN	MM	IN	MM	IN	KG	LB
393029800	393029802	0	175	6 7/8	322	12 11/16	4	5/32	5	3/16	156	6 1/8	303	11 15/16	5	3/16	1.3	2.9		
393129800	393129802	1	190	7 1/2	366	14 7/16	4	5/32	5	3/16	171	6 3/4	347	13 11/16	5	3/16	1.6	3.5		
393329800		3	190	7 1/2	448	17 11/16	4	5/32	5	3/16	171	6 3/4	429	16 7/8	5	3/16	2.0	4.4		
393429800		4	190	7 1/2	645	25 7/16	4	5/32	5	3/16	171	6 3/4	626	24 11/16	5	3/16	2.8	6.2		
393529800		5	263	10 11/32	448	17 5/8	4	5/32	5	3/16	244	9 5/8	429	16 7/8	5	3/16	2.6	5.7		

### Flush Mitre Custom Size Portlight Specifications

PART NUMBER GREY	PART NUMBER DARK GREY	FLYSCREEN	OVERALL DIMENSIONS										CUT-OUT DIMENSIONS					
			X WIDTH		Y LENGTH		Z HEIGHT		R RADII		X1 WIDTH		Y1 LENGTH		R1 RADII			
			MM	IN	MM	IN	MM	IN	MM	IN	MM	IN	MM	IN	MM	IN		
30216000		30277800	115	4 1/2	322	12 43/64	4	5/32	5	3/16	96	3 25/32	303	11 15/16	5	3/16		
	30179600		180	7 5/64	490	19 9/32	4	5/32	5	3/16	161	6 11/32	471	18 35/64	5	3/16		
30183700		30222000	150	5 29/32	600	23 5/8	4	5/32	5	3/16	131	5 5/32	581	22 7/8	5	3/16		
	30184900		200	7 7/8	490	19 9/32	4	5/32	5	3/16	181	7 1/8	471	18 35/64	5	3/16		
30187100			270	10 5/8	900	35 7/16	4	5/32	5	3/16	251	9 7/8	881	34 11/16	5	3/16		
30196200		30206400	360	14 11/64	500	19 11/16	4	5/32	5	3/16	341	13 27/64	481	18 15/16	5	3/16		
30196300		30206500	300	11 13/16	564	22 16/64	4	5/32	5	3/16	281	11 1/16	545	21 29/64	5	3/16		
30196400		30206600	360	14 11/64	680	26 49/64	4	5/32	5	3/16	341	13 27/64	661	26	5	3/16		
30198700		30206300	338	13 19/64	360	14 11/64	4	5/32	5	3/16	319	12 9/16	341	13 27/64	5	3/16		
30203300			440	17 21/64	354	13 15/16	4	5/32	5	3/16	421	16 37/64	335	13 3/16	5	3/16		

FLYSCREEN NOT SUPPLIED AS STANDARD  
CE APPROVAL TO CATEGORY A, AREA 2B FOR SIZES UP TO 200X600.

### Flush Mitre Fixedlight Specifications

PART NUMBER GREY	PART NUMBER DARK GREY	PART NUMBER CLEAR	OVERALL DIMENSIONS										CUT-OUT DIMENSIONS					
			X WIDTH		Y LENGTH		Z HEIGHT		R RADII		X1 WIDTH		Y1 LENGTH		R1 RADII			
			MM	IN	MM	IN	MM	IN	MM	IN	MM	IN	MM	IN	MM	IN		
30192000	30183800	30192200	150	5 29/32	600	23 5/8	4	5/32	5	3/16	131	5 5/32	581	22 7/8	5	3/16		
30212200			174	6 7/8	423	16 21/32	4	5/32	5	3/16	155	6 7/64	404	15 29/32	5	3/16		
	30211800		193	7 19/32	648	25 33/64	4	5/32	5	3/16	174	6 35/64	629	24 49/64	5	3/16		
30212200			240	9 29/64	700	27 9/16	4	5/32	5	3/16	221	8 45/64	681	26 13/16	5	3/16		

CE APPROVAL TO CATEGORY A, AREA 1 ON SIZE 150X600

## 4. Hatch & Portlight



### Stainless Steel Portlight

With its highly polished stainless outer frame, the Stainless Portlight offers a clean, modern look. The handles and hinge system are designed to leave the lens clear of obstructions, giving an uncluttered view.

- ABS plastic trim
- Easily fitted by clamping the cabin sides between inner and outer frame with screws provided that are fastened into the outer frame
- Can be installed with sealant or closed cell PVC tape
- Trim with clean styling
- Full range of spare parts available online at [www.lewmar.com](http://www.lewmar.com)

Specifications options:

- Handles: clip (standard) / twist (option)
- Moulding colour: grey
- Acrylic colour: grey (standard), other colours available
- Frame colour: stainless steel
- Comes complete with trim and flyscreen



Stainless steel Portlight Dimensions

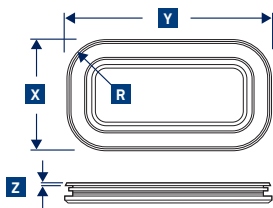

Stainless steel Portlight Cut-out

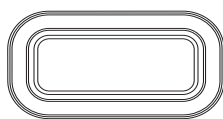
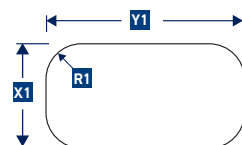

Size 0

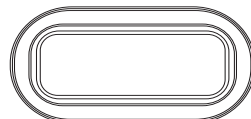

Size 1

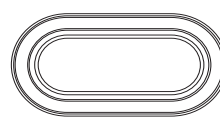

Size 1RE



Size 7RE



Size 8



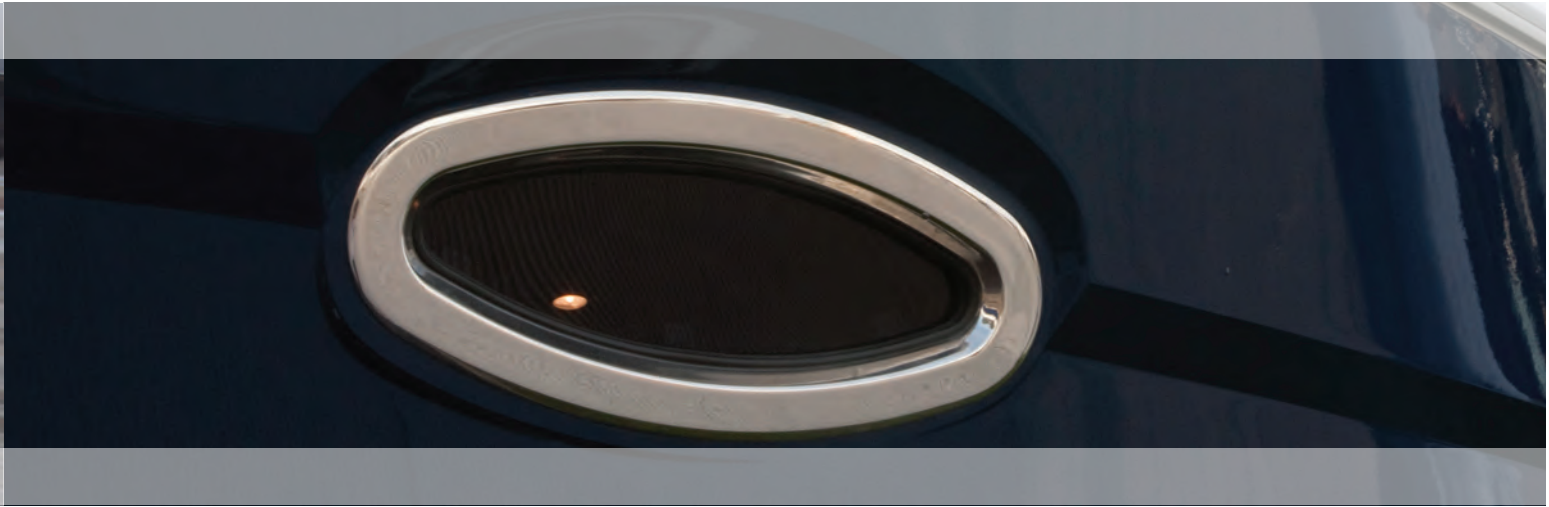

PART NUMBER	SIZE	TRIM COLOUR	VERSION	OVERALL DIMENSIONS								CUT-OUT DIMENSIONS						PORTLIGHT WEIGHT		ACRYLIC WINDOW THICKNESS	
				X LENGTH		Y WIDTH		Z HEIGHT		R RADII		X1 LENGTH		Y1 WIDTH		R1 RADII		KG	LB	MM	IN
				MM	IN	MM	IN	MM	IN	MM	IN	MM	IN	MM	IN	MM	IN				
393020262	0	WHITE	OPENING	176	6 15/16	323	12 11/16	4	5/32	62.0	2 7/16	156	6 1/8	303	12	52.0	2 1/16	1.5	3.30	8	1/2
393010262	0	WHITE	FIXED	176	6 15/16	323	12 11/16	4	5/32	62.0	2 7/16	156	6 1/8	303	12	52.0	2 1/16	1.5	3.30	10	3/8
393120262	1	WHITE	OPENING	191	7 1/2	367	14 7/16	4	5/32	62.0	2 7/16	171	6 3/4	347	13 5/8	52.0	2 1/16	1.7	3.80	8	1/2
393110262	1	WHITE	FIXED	191	7 1/2	367	14 7/16	4	5/32	62.0	2 7/16	171	6 3/4	347	13 5/8	52.0	2 1/16	1.7	3.80	10	3/8
393180262	1RE	WHITE	OPENING	191	7 1/2	367	14 7/16	4	5/32	95.5	3 3/4	171	6 3/4	347	13 5/8	85.5	3 3/8	1.7	3.74	10	3/8
393170262	1RE	WHITE	FIXED	191	7 1/2	367	14 7/16	4	5/32	95.5	3 3/4	171	6 3/4	347	13 5/8	85.5	3 3/8	1.7	3.74	10	3/8
393780262	7RE	WHITE	OPENING	191	7 1/2	425	16 3/4	4	5/32	95.5	3 3/4	171	6 3/4	405	15 15/16	85.5	3 3/8	1.9	4.18	10	3/8
393770262	7RE	WHITE	FIXED	191	7 1/2	425	16 3/4	4	5/32	95.5	3 3/4	171	6 3/4	405	15 15/16	85.5	3 3/8	1.9	4.18	10	3/8
393820862	8	CHROME	OPENING	196	7 11/16	452	17 13/16	4	5/32	N/A	N/A	SEE DRAWING ON WEBSITE						1.9	4.18	10	3/8
393810862	8	CHROME	FIXED	196	7 11/16	452	17 13/16	4	5/32	N/A	N/A	SEE DRAWING ON WEBSITE						1.9	4.18	10	3/8

## Round Stainless Steel Portlight

### Round stainless steel Portlight Dimensions

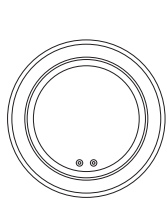

Round 250mm

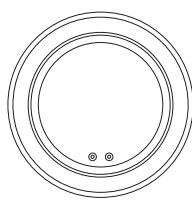

Round 296mm

### Cut-out Dimensions

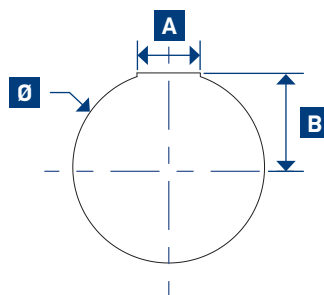

### Round Stainless Steel Portlight Specifications

PART NUMBER	TRIM COLOUR	VERSION	OVERALL Ø		CUT-OUT DIAMETER						WEIGHT		THICKNESS	
			MM	IN	Ø	A		B		KG	LB	MM	IN	
						MM	IN	MM	IN					
30209800	CHROME	OPENING	250	9 7/8	230	9 1/16	76	3	113	4 7/16	1.4	3	10	3/8
30209900	CHROME	OPENING	296	11 5/8	277	10 7/8	100	3 15/16	136	5 3/8	2.0	4	10	3/8

Maximum hull thickness 24mm

Minimum hull thickness 8mm

All portlights are supplied with M5 x 12 fastenings

Flyscreen available for the Round Stainless Portlights

## 4. Hatch & Portlight



### Standard Portlight

A perfect match for any hatch in the Lewmar range, the Standard Portlight is stylish, competitively priced and easy to use and install.

- Easily fitted by clamping the cabin sides between inner and outer frame with screws that are fastened into the outer frame
- Can be installed with sealant or closed cell PVC tape
- White ABS Plastic Trim
- Cut out shape available from [www.lewmar.com](http://www.lewmar.com)
- Supplied complete with flyscreen (except sizes 4L and 4R)
- Full range of spare parts available on-line [www.lewmar.com](http://www.lewmar.com)



Size 0

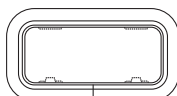

Size 1

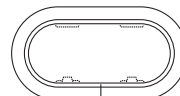

Size 1RE

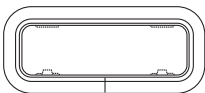

Size 2

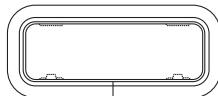

Size 3

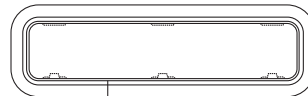

Size 4

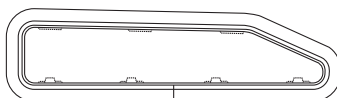

Size 4R

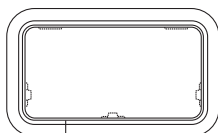

Size 5

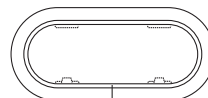

Size 7RE



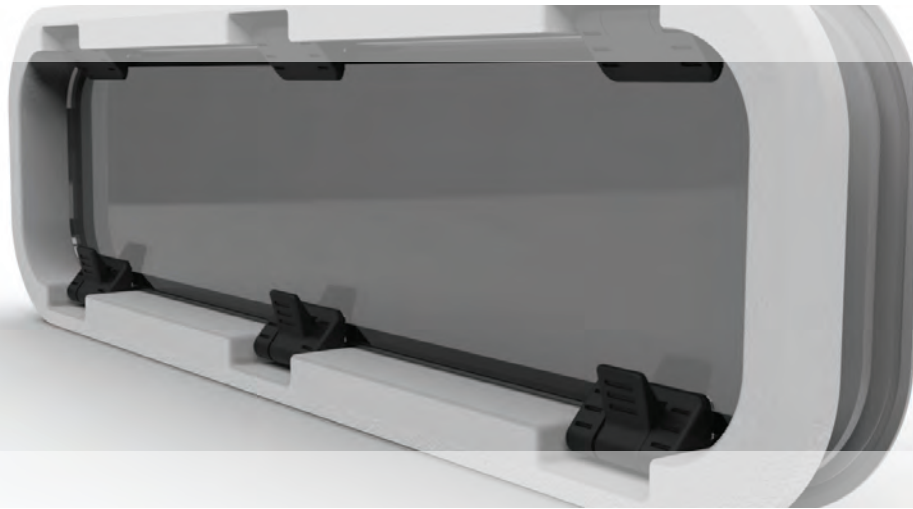

**Specifications options:**

- Handles: clip (standard) / twist (option)
- Moulding colour: grey
- Acrylic colour: grey (standard), other colours available
- Frame colour: Silver anodized (standard), other finishes available
- Come complete with trim and flyscreen

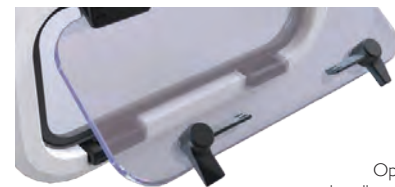

Optional twist handle, contact your Lewmar representative for part numbers

**Standard Portlight Dimensions**

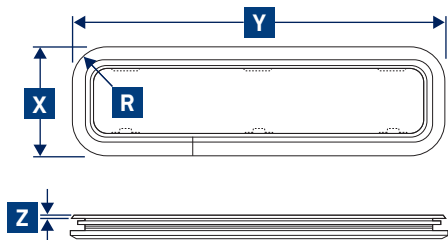

**Standard Portlight Cut-out**

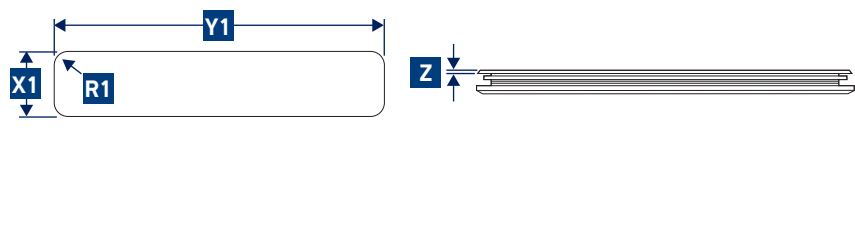

PART NUMBER	SIZE	OVERALL DIMENSIONS								CUT-OUT DIMENSIONS						PORTLIGHT WEIGHT		ACRYLIC WINDOW THICKNESS	
		X LENGTH		Y WIDTH		Z HEIGHT		R RADII		X1 LENGTH		Y1 WIDTH		R1 RADII					
		MM	IN	MM	IN	MM	IN	MM	IN	MM	IN	MM	IN	MM	IN	KG	LB	MM	IN
393020200	0	176	6 15/16	323	12 11/16	4	5/32	62.0	2 7/16	156	6 1/8	303	11 15/16	52.0	2 1/16	1.1	2.42	6	1/4
393120200	1	191	7 1/2	367	14 7/16	4	5/32	62.0	2 7/16	171	6 3/4	347	13 11/16	52.0	2 1/16	1.3	2.86	6	1/4
393180200	1RE	191	7 1/2	367	14 7/16	4	5/32	95.5	3 3/4	171	6 3/4	347	13 11/16	85.5	3 3/8	1.3	2.86	8	5/16
393220200	2	176	6 15/16	425	16 3/4	4	5/32	62.0	2 7/16	156	6 1/8	405	15 5/16	52.0	2 1/16	1.4	3.08	8	5/16
393320200	3	191	7 1/2	449	17 11/16	4	5/32	62.0	2 7/16	171	6 3/4	429	16 7/8	52.0	2 1/16	1.7	3.74	10	3/8
393420200	4	191	7 1/2	646	25 7/16	4	5/32	62.0	2 7/16	171	6 3/4	626	24 11/16	52.0	2 1/16	2.4	5.28	8	5/16
393440200	4R	195	7 11/16	708	27 7/8	4	5/32	62.0	2 7/16	175	6 7/8	688	27 1/16	52.0	2 1/16	2.4	5.28	8	5/16
393460200	4L	195	7 11/16	708	27 7/8	4	5/32	62.0	2 7/16	175	6 7/8	688	27 1/16	52.0	2 1/16	2.4	5.28	8	5/16
393520200	5	264	10 3/8	449	17 11/16	4	5/32	62.0	2 7/16	244	9 5/8	429	16 7/8	52.0	2 1/16	2.3	5.15	10	3/8
393780200	7RE	191	7 1/2	425	16 3/4	4	5/32	95.5	3 3/4	171	6 3/4	405	15 15/16	85.5	3 3/8	2.4	5.28	8	5/16

Maximum hull thickness 34mm

Minimum hull thickness 7mm

All portlights are supplied with 12 off M5 x 25 screws for hull thickness 17-25mm

Portlights should be fitted to a flat surface +/- 1mm

## 4. Hatch & Portlight



### Atlantic Portlight

The Atlantic Portlight has clean lines and proven offshore pedigree.

- Extensive range
- Flyscreens provided as standard
- Friction hinges
- Screw handles available as an option
- Full range of spare parts available on-line [www.lewmar.com](http://www.lewmar.com)

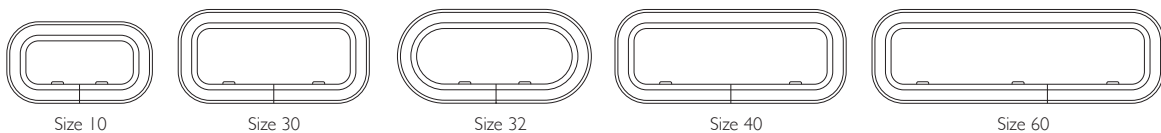

#### Specifications options:

- Clip handles standard / Screw handles optional
- Acrylic colour: Grey (standard) other colour optional
- Frame colour: Silver anodized (standard) other finish available
- Come complete with alloy valance and flyscreen
- Portlights and fixed lights come complete with fastenings as indicated in the table

#### Portlight Valance & Fastening

HULL THICKNESS MM	VALANCE TYPE	FASTENING	
8–10	THIN HULL VALANCE	360360999 <sup>1</sup>	M5 X 12MM LONG
11–15	THIN HULL VALANCE	360361999	M5 X 16MM LONG
16–19	THICK HULL VALANCE	360362999	M5 X 20MM LONG
20–24	THICK HULL VALANCE	360363999 <sup>2</sup>	M5 X 25MM LONG

<sup>1</sup> Supplied as standard with thin hull valances

<sup>2</sup> Supplied as standard with thick hull valances

Fastenings supplied in bags of 100



Atlantic Portlight Dimensions

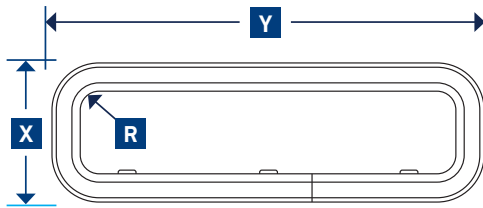

Atlantic Portlight Cut-out

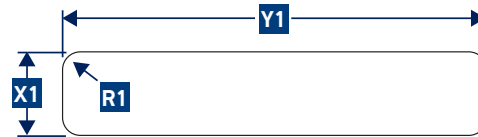

PART NUMBER		SIZE	OVERALL DIMENSIONS								CUT-OUT DIMENSIONS						PORTLIGHT WEIGHT		ACRYLIC WINDOW THICKNESS	
THIN VALANCE	THICK VALANCE		X LENGTH		Y WIDTH		Z HEIGHT		R RADI		X1 LENGTH		Y1 WIDTH		R1 RADI		KG	LB	MM	IN
MM	IN	MM	IN	MM	IN	MM	IN	MM	IN	MM	IN	MM	IN	MM	IN	MM	IN	MM	IN	
39110090	39110070	10	174	6 15/16	304	12	6	1/4	71	2 13/16	154	6 1/16	284	11 3/16	61	2 3/8	1.6	3.5	8	5/16
39130090	39130070	30	200	7 7/8	400	15 3/4	6	1/4	71	2 13/16	180	7 1/16	380	14 15/16	61	2 3/8	2.2	4.8	8	5/16
39132090	39132070	32	198	7 13/16	401	15 13/16	6	1/4	99	3 7/8	178	7	381	15	89	3 1/2	2.1	4.6	8	5/16
39140090	39140070	40	200	7 7/8	480	18 7/8	6	1/4	71	2 13/16	180	7 1/16	460	18 1/8	61	2 3/8	2.5	5.5	8	5/16
39160090	39160070	60	200	7 7/8	600	23 5/8	6	1/4	71	2 13/16	180	7 1/16	580	22 13/16	61	2 3/8	3.0	6.6	8	5/16

Specifications options:

- Smoke grey acrylic and silver anodise frames
- Should be fitted to a flat surface with a max tolerance of ± 1mm
- Come complete with fastenings as indicated on above table
- Portlight opening is restricted on very thick hulls.
- At 24mm hull thickness opening angle is 115°



SIZES 10,30,32  
AREA 1  
SIZES 40,60  
AREA 2A  
SEE PAGE 132

## 4. Hatch & Portlight

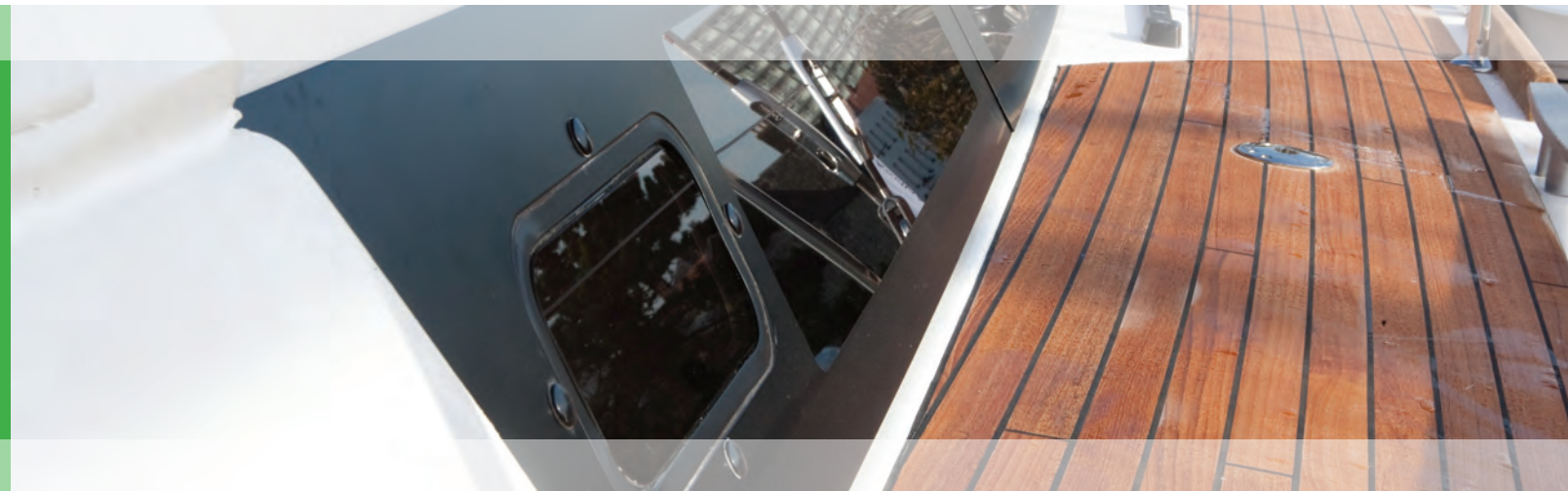

### Concept 3 Portlight

The Concept 3 portlight enables the integration of an opening portlight into larger expanses of acrylic. Discreet fastenings and a thin exterior frame minimise the aesthetic compromise as much as possible.

Supplied as a discrete unit, the Concept 3 provides an additional option for boat builders to offer their customers who desire additional ventilation without compromising design or watertight integrity.

- Supply ventilation into the cabin without compromising sleek design lines
- Portlight designed to sit flush in a 8mm thick panel/coachroof
- Seal design based on our proven New Standard platform

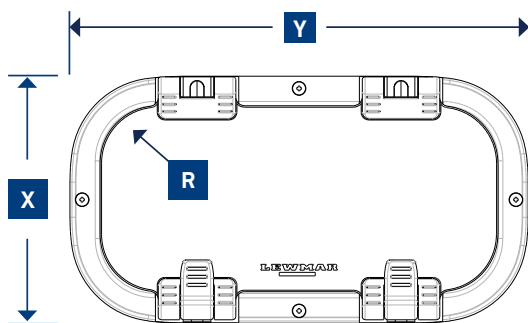

PART NUMBER	FLYSCREEN	OVERALL DIMENSIONS						CUT-OUT DIMENSIONS						ACRYLIC WINDOW THICKNESS		CE CERTIFICATION
		X		Y		R		X1		Y1		R1		MM	IN	
		MM	IN	MM	IN	MM	IN	MM	IN	MM	IN	MM	IN			
30193600	30204400	319	12 1/2	172	6 3/4	61	2 1/2	280	11	133	5 1/4	39	1 1/2	25	1	CATEGORY A, AREA 2B
30216100		360	14 3/16	162	6 3/8	61	2 1/2	321	12 5/8	123	4 13/16	39	1 1/2	25	1	CATEGORY B, AREA 1

FLYSCREEN NOT SUPPLIED AS STANDARD  
CE APPROVAL TO CATEGORY A, AREA 2B FOR SIZES UP TO 200X600.





## Flush Trimports

The Flush Trimport provides yacht designers with an alternative way of styling the coachroof coaming.

The trimport is a long, thin, outward opening hatch. On the outside of the yacht a long, uninterrupted panel provides a supremely smooth aesthetic. The outward opening removes the issue experienced with conventional portlights of water running off the lens and into the boat.

Flush Trimports must be integrated into the vessel at the design stage as custom shapes are required for each boat model.

- Based on flush hatch platform
- Flexible sizing to suit OEM requirements
- Flyscreen not supplied as standard
- Contact Lewmar for further information

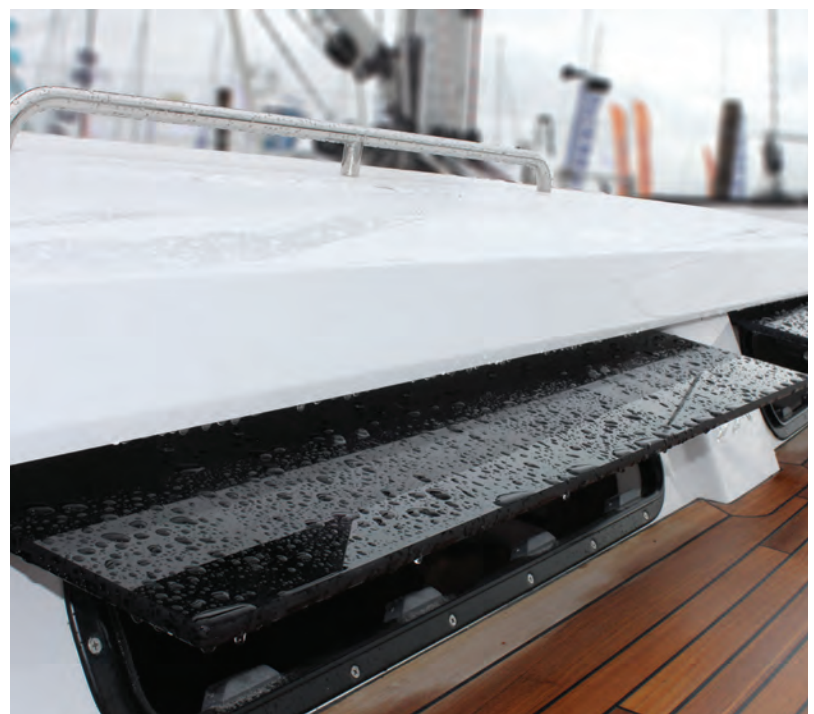

# 4. Hatch & Portlight

## Portlight Accessories and Spares

### Portlight Flyscreen

Portlight Flyscreen provides easy installation and removal.

Note: Portlight cannot be closed with flyscreen in place

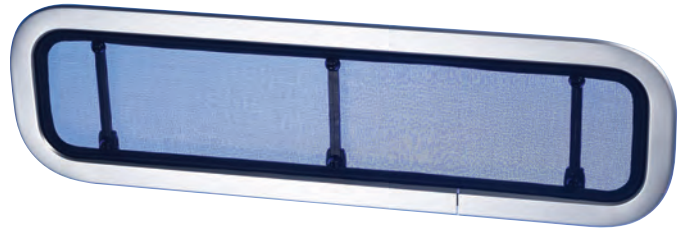

### Standard Portlight Clip Flyscreens



### Atlantic Portlight Clip Flyscreens



### Stainless Portlight Flyscreens



PART NUMBER	TO SUIT STANDARD PORTLIGHT
367302936	SIZE 0
367312936	SIZE 1
367318936	SIZE 1RE
367322936	SIZE 2
367332936	SIZE 3
367342936	SIZE 4
367352936	SIZE 5
367378936	SIZE 7RE

PART NUMBER	TO SUIT ATLANTIC PORTLIGHT
367110936	SIZE 10
367130936	SIZE 30
367132936	SIZE 32
367140936	SIZE 40
367160936	SIZE 60

PART NUMBER	TO SUIT STAINLESS PORTLIGHT
367318966	SIZE 1RE
367378966	SIZE 7RE
367382966	SIZE 8 ELLIPTICAL

PART NUMBER	TO SUIT ROUND STAINLESS PORTLIGHT
30204300	SIZE 250
30205100	SIZE 296

### Portlight Fastenings

PART NUMBER	SCREW SIZE	HULL THICKNESS mm			
		STANDARD PORTLIGHT		STAINLESS STEEL PORTLIGHT	
		MIN	MAX	MIN	MAX
19899000	M5 X 12	7	9	7	9
19899100	M5 X 16	8	13	8	13
19899200	M5 X 20	12	17	12	17
19899300	M5 X 25	17	22	17	22
19899400	M5 X 30	22	27	22	27
19899500	M5 X 35	27	32	27	32
19899600	M5 X 40	32	34	32	34

Screws supplied in quantities of 100

### New Standard Seal

PART NO	PORTLIGHT SIZE
360758999	0
360759999	1
360760999	2
360761999	3
360762999	4
360763999	4L
360763999	4R
360765999	5
361109999	7RE

### Flush Mitre Acrylic

For over cam handles

PART NO	SIZE
361724029	0 (GREY)
361725029	1 (GREY)
361726029	3 (GREY)
361727029	4 (GREY)
361728029	5 (GREY)
361724829	0 (DARK GREY)
361725829	1 (DARK GREY)
361726829	3 (DARK GREY)
361727829	4 (DARK GREY)

### New Standard Acrylic

For Mk 2 (post-2000) portlights with over cam handles

PART NO	SIZE
360750009	0
360751009	1
360752009	2
360753009	3
360754009	4
360755009	4L
360756009	4R
360757009	5
361009009	7RE

### Atlantic Portlight Lid Spare

For opening portlights

PART NO	SIZE
360532009	10
360533009	30
360534009	32
360684009	40
360686009	60

## How To Identify Your Lewmar Portlight

Portlights Produced after October 1997 (with the exception of the Old Standard) have Lewmar, the name of the range, the portlight size, and a date code stamped on the acrylic.

All models available in opening, Portlights, or non-opening versions, Fixedlights.

IDENTIFYING FEATURES	OLD STANDARD	NEW STANDARD	ATLANTIC MK.1	OCEAN
PRODUCTION DATES	1982 - 1998	1997 - NOW	1994 - NOW	1990 - 2000
ALLOY FRAME AROUND ACRYLIC			*	*
PLASTIC HANDLES TURN LIKE KEYS TO OPEN	*			
PLASTIC HANDLES PUSH TO CLOSE		*		*
METAL HANDLES PUSH TO CLOSE			*	
PORTLIGHT CLICKS THROUGH POSTIONS AT WHICH WILL STAY OPEN	*			*

### (Old) Standard Portlight

- Produced 1982-1998
- No frame around acrylic
- Plastic handles and hinges fastened through acrylic
- Plastic turn to close handles
- 2 frame joins on outside of portlight



### New Standard Portlight

- Produced 1997 to date
- No frame around acrylic
- Plastic handles and hinges glued to acrylic
- Plastic push to close handles
- 1 frame join on outside of portlight
- Interior ABS trim clips into place
- Interior ABS trim fitted with velcro type strips.
- Seals, Hinges & Acrylics still available for standard sizes



### Atlantic Portlight

- Produced 1994 to date
- Alloy frame around acrylic
- Metal push to close handles
- 1 frame joint in outside of portlight
- Alloy interior trim



### Ocean Portlight

- Produced 1990 to 2000
- One size available
- Alloy frame around acrylic
- Plastic handles push sideways to close handles
- Cast frame - no joins on outside of portlight
- Interior ABS trim fitted with velcro type strips.
- Deadlights available



## 4. Hatch & Portlight



### Roller Shade

Designed for the perfect fit to our existing range of hatches, the new modular blind system complements today's stylish interiors. Easy to assemble, fit, maintain and adjust, our new shade range is the perfect addition to our great hatch & portlight range.

All components have been specially selected for their suitability in withstanding the harsh marine environment. The chosen polymers and fabrics are designed to look good within the interior of any boat and are easy to keep clean and offer excellent resistance to damp conditions. Simple and clean in design, our range will complement the internal styling of your boat and provide you with a perfect solution to insect and light protection.

Finding a hatch or port shade to match what you need has never been easier:

- Easy to install – 4 simple parts
- 100% blackout material that is UV stable, wipe clean and water repellent
- Durable flyscreen mesh, providing protection and airflow
- Low profile design
- Adjustable tensioning mechanism
- Suitable for all Lewmar standard hatch sizes
- Internal trims also available





- **Design**

Modular joining system for simple installation and maintenance

- **Connectors**

Magnetic connectors for easy stowing and operation

- **Fabrics**

Moisture- and mould-resistant fabrics make up the blackout solar shade & Lewmar flyscreen



PART NUMBER	SIZE	<b>W</b> OPENING WIDTH	<b>Z</b> OPENING HEIGHT	<b>X</b> OVERALL WIDTH	<b>Y</b> OVERALL HEIGHT
367710100	10	262	262	344	398
367720100	20	349	204	431	340
367730100	30	459	329	541	465
367740100	40	423	423	505	559
367741100	41	423	178	505	314
367744100	44	444	444	526	580
367750100	50	509	379	591	515
367754100	54	509	394	591	530
367760100	60	509	509	591	645
367770100	70	629	629	711	765
367780100	78	721	771	803	907

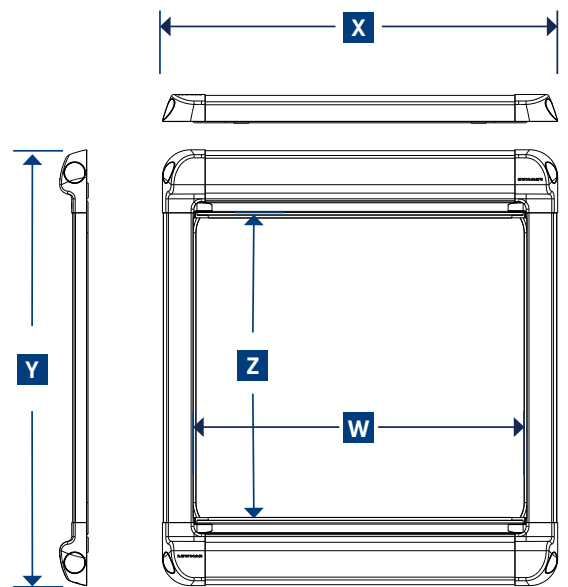

## 4. Hatch & Portlight



### Pleated Shade

Designed on the Lewmar platform, the pleated design offers the reliable modular configuration of the roller shade combined with stylish & contemporary pleated fabrics.

From size 10 to 70, Pleated shade is an elegantly pleated flyscreen and 100% blackout blind. While the blackout blind provides absolute darkness, the flyscreen yields atmospheric and pest free conditions. Simple and clean in design, the pleated shade can be mounted directly to the headlining of any vessel or can be mounted in the headlining as a flush pleated solution.

- Easy to install – surface or flush mount option
- 100% honeycomb black out material, UV stable
- Low profile design
- Suitable for all Lewmar standard hatch sizes
- Internal trims also available





- **Design**

Modular design that can be mounted direct to the headlining or in a flush application

- **Connectors**

Magnetic connectors for simple, easy stowing and movement between screens

- **Fabrics**

Moisture- and mould-resistant fabrics with pleated 100% blackout solar shade & Lewmar pleated flyscreen



PART NUMBER	SIZE	<b>W</b> OPENING WIDTH	<b>Z</b> OPENING HEIGHT	<b>X</b> OVERALL WIDTH	<b>Y</b> OVERALL HEIGHT
367710400	10	263	263	306	306
367720400	20	350	205	393	248
367730400	30	460	330	503	373
367740400	40	424	424	467	467
367744400	44	445	445	488	488
367750400	50	381	510	424	553
367754400	54	510	395	553	438
367760400	60	510	510	553	553
367770400	70	630	630	673	673

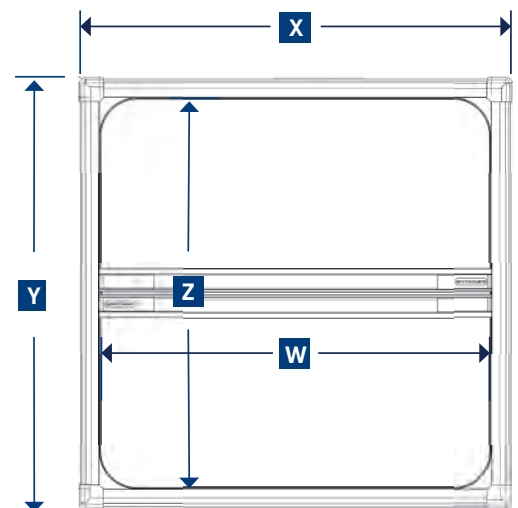

## 4. Hatch & Portlight

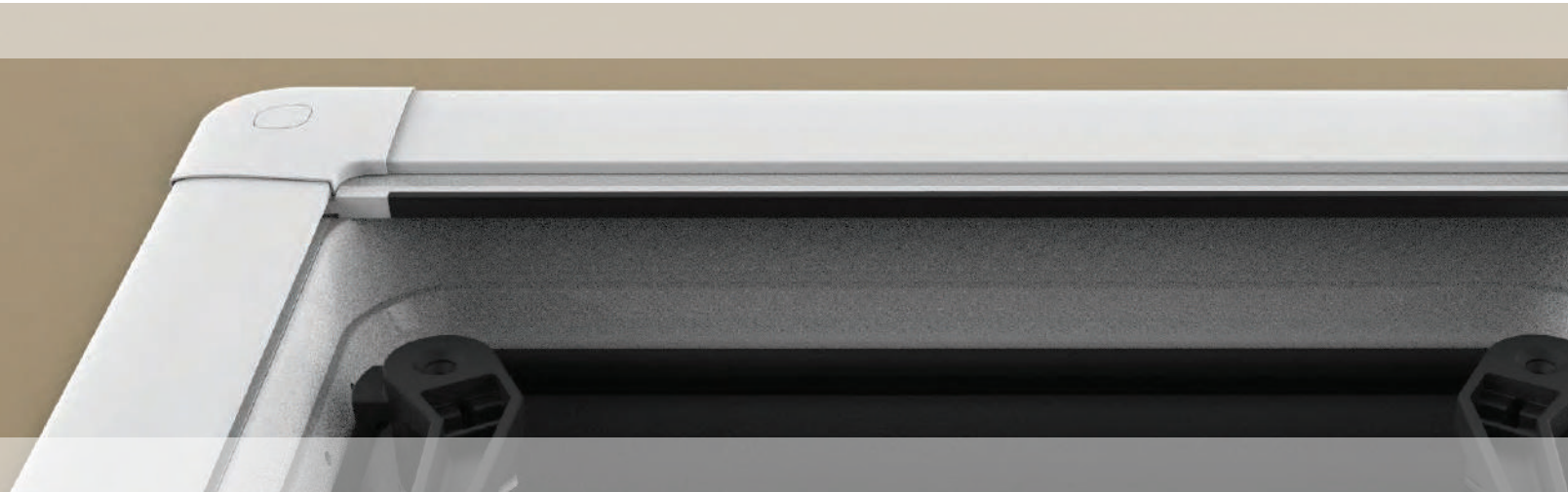

### Flush Roller Shade

The Lewmar Flush Roller Shade is available as an integrated OEM solution, designed to offer the reliable modular configuration of the Lewmar Roller Shade in a stylish and contemporary flush solution.

Designed to sit flush within a yacht's headlining, the Flush Roller is a design for the fast-paced OEM market. With a durable and stylish composite extrusion, the shade is fitted with a Lewmar flyscreen and blackout shade. Designed to match Lewmar hatch sizes 10 to 70, this new flush design offers a seamless look in your cabin while retaining all the benefits of the Lewmar Roller Shade systems.

- Easy to install – 4 simple parts
- 100% black out material that is UV stable, wipe clean and water repellent
- Durable flyscreen mesh, providing protection and airflow
- Adjustable tensioning mechanism
- Flush design
- Suitable for all Lewmar standard hatch sizes
- Internal trims also available







▪ **Design**

Flush modular joining system for simple installation and maintenance

▪ **Connectors**

Magnetic connectors for easy stowing and movement of screens

▪ **Fabrics**

Moisture- and mould-resistant fabrics with blackout solar shade and Lewmar flyscreen

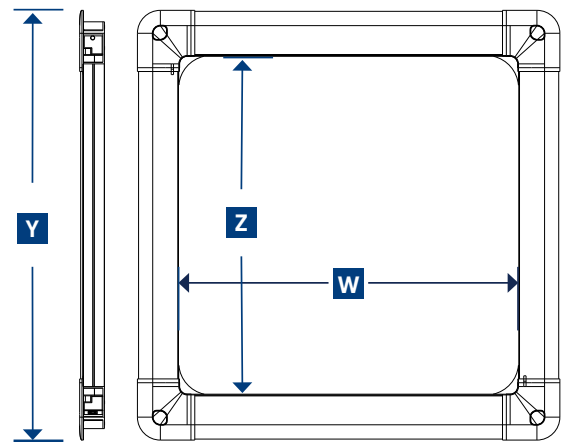

PART NUMBER	SIZE	OPENING WIDTH (w)	OPENING HEIGHT (z)	OVERALL WIDTH (x)	OVERALL HEIGHT (y)
367710200	10	263	263	371	381
367720200	20	350	205	458	323
367730200	30	460	330	568	448
367740200	40	424	424	532	542
367744200	44	445	445	553	563
367750200	50	381	510	489	628
367754200	54	510	395	618	513
367760200	60	510	510	618	628
367770200	70	630	630	738	748

## 4. Hatch & Portlight



### Portshade

Designed for the perfect fit to our existing range of portlights, the Portshade system complements our range of shades.

Quick and simple to install, the Lewmar Portshade is a low profile cassette roller blind, suitable for Lewmar portlight sizes 0 to 5. Portshades can be mounted vertically or horizontal, with the added advantage of being perfectly suited for the curved surface application.

- Easy to install – 2 simple parts
- 100% black out material that is UV stable, wipe clean and water repellent
- Compatible with standard Lewmar portlight sizes

#### ▪ Design

Simple fitting with 2 screw installation, suitable for vertical or horizontal mounting

#### ▪ Fabric

100% black out material that is UV stable, wipe clean and water repellent

#### ▪ Fixing

Stylish pull down tabs and easy-locking catch

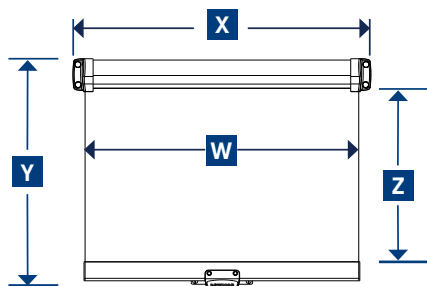

PART NUMBER	SIZE	X OVERALL WIDTH	Y OVERALL HEIGHT	W SHADE WIDTH	Z SHADE HEIGHT
367700300	SIZE 0	409	422	340	280
367710300	SIZE 1 / 1RE	449	422	380	280
367730300	SIZE 2/3/5	529	462	460	320
367740300	SIZE 4	729	462	660	320
367745300	SIZE 4R / 4L	789	462	720	320



## Trim Kits

Complements and covers any gaps between the shade and hatch frame. The trim clips into the shades, simply cut down to adjust to fit any hatch depth.

- Accommodates all Lewmar hatch sizes
- Minimalist and stylish design, hard wearing and easy to clean
- UV resistant material, durable, light reflective and light weight



PART NO.	SIZE
367710150	10
367720150	20
367730150	30
367740150	40
367744150	44
367750150	50
367754150	54
367760150	60
367770150	70

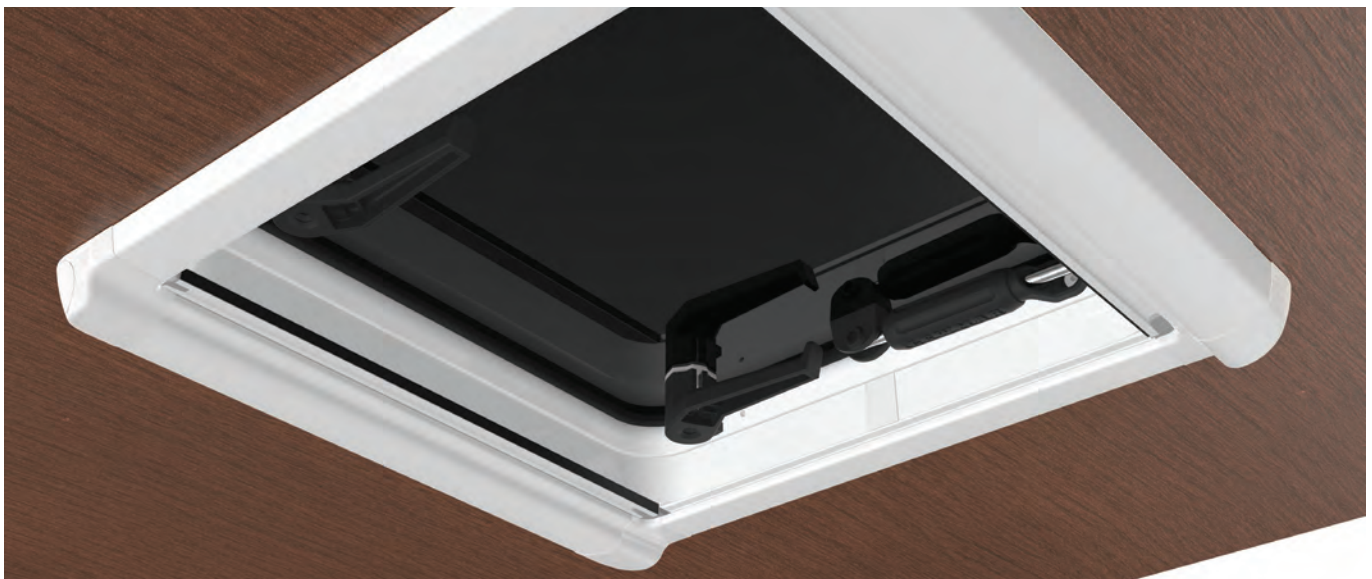



## 5. Glass

With market-leading experience in fixed and opening glazing, Lewmar provides cutting edge, well-engineered, long-lasting solutions.

# CE Regulations

The CE Regulations apply to craft up to 24m in length that are sold in the European Union. Although the Regulations may not apply to your boat, they are a useful guide for small craft throughout the world.

- The Regulations have Design Categories for boats based on their intended usage and propulsion (sail or power). Boats built to CE Regulations are fitted with a plate showing the Design Category.
- All Lewmar glass products are for Design Category A (Ocean Sailing) or Design Category B (Offshore Sailing).
- The Regulations divide up the hull and deck into four specific 'areas'. These are shown below.

- For craft with a freeboard greater than 1/12 of its overall length, the hull is split into Area 1 and Area 2B. Please refer to the Recreational Craft Directive 94/25/EC.
- A product that is suitable for fitting to an area for which it is approved is suitable for all the areas below its category. For example, a portlight that is approved for Area 2A may also be fitted to Areas 3 and 4, but not Areas 1 or 2B.
- All the hatches and portlights in this publication are CE Approved for the areas indicated on the product pages.
- Lewmar warranties are invalid if the product is installed in an area where it is not intended, and if the installation fails to meet the requirements of the CE Regulations.

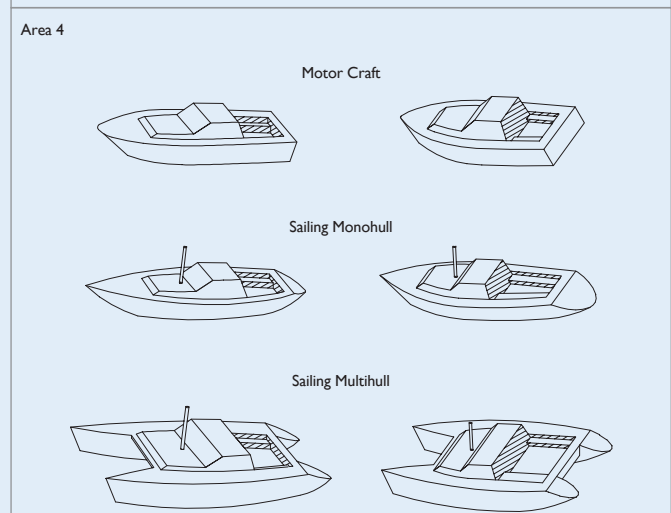
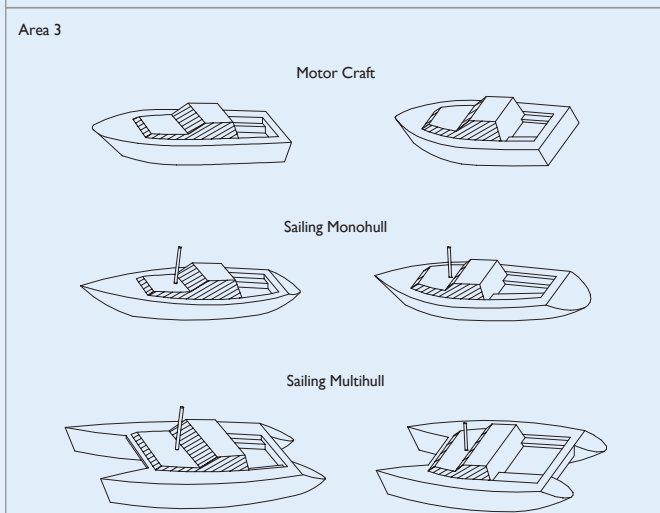
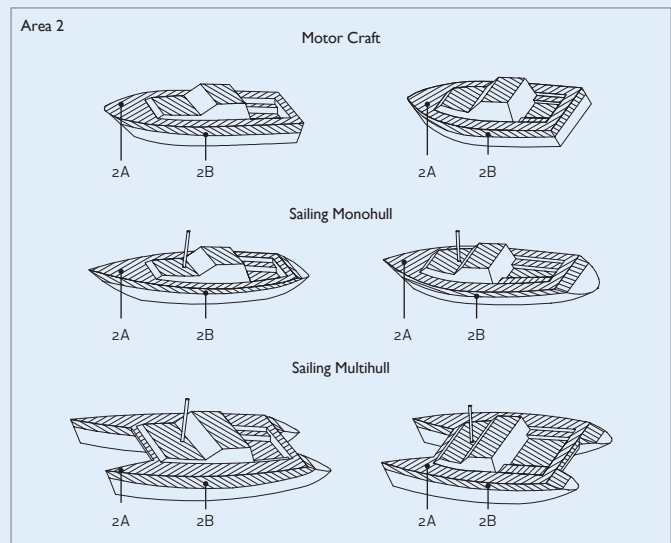
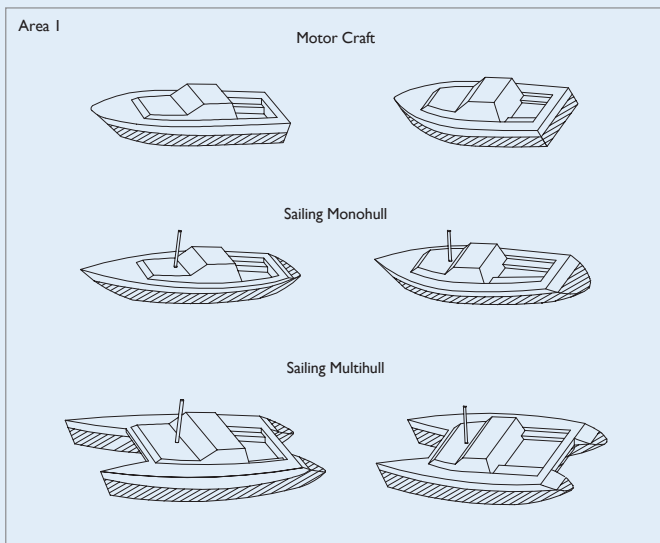

## 5. Glass & Glazing



With 70 years of marine industry experience and knowledge Lewmar is recognised around the world as the leading supplier of hatches and portlights. Since 2014 Lewmar has invested significantly in manufacturing equipment to bring glass and glazing production to our UK factory. Our capabilities include flat, curved, monolithic and laminated glass panels which can be enhanced with pre-assembled stylish manual and electric opening platforms or flush portlights.



Lewmar's commitment to the latest technology is demonstrated via its two industry-leading, full-colour, 1440 DPI digital printers. Efficient in-house manufacturing allows the ultimate flexibility and control. Unlike with traditional production methods, there is no heavy up-front tooling cost for either custom curved panels or individually designed frit or graphic design. This capability allows Lewmar to collaborate closely with clients from unique one off designs to high-volume production builders.

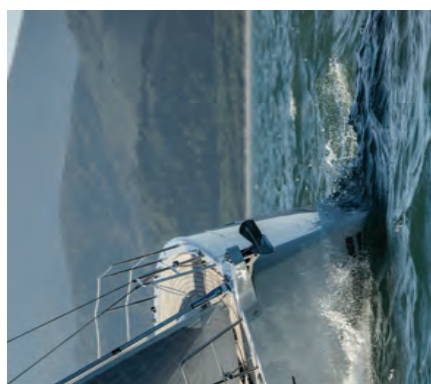



With a proven track record in the industry, Lewmar's engineering team develop their standard products to ISO12216. Our team includes specialists on regulatory matters who work closely with key clients to optimise their glazing design and specification, maximising internal light and minimising weight.

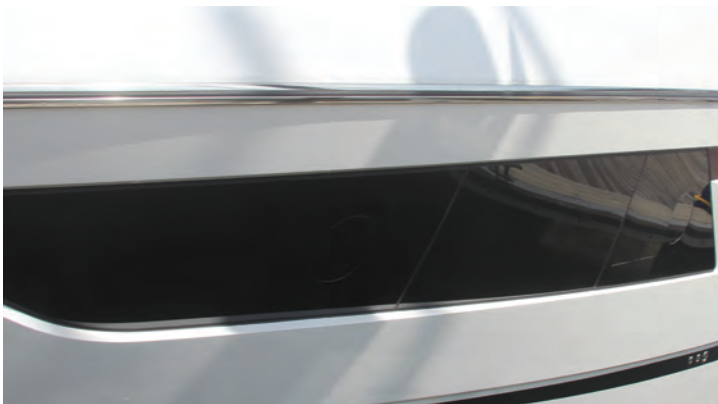

At its Havant, UK headquarters, Lewmar offers full in-house testing capabilities and works closely with a wide range of classification societies and notified bodies, including RINA, Lloyds, DNV-GL, ABS, IMCI & HPI. This ensures regulatory compliance for the vessel and peace of mind for the builder and owner.



## 5. Glass & Glazing



### In-Hull Glazing

#### Monolithic

Using high-quality raw materials from Pilkington & AGC, Lewmar offers a full range of monolithic glass solutions. Standard thickness sizes range from 4 to 19mm with others available on request. Available colors include clear, European grey and super silver (mirrored finish).



#### Laminated

Alongside monolithic panels, Lewmar has full in-house lamination capabilities. Operating in a strict pressure and temperature controlled clean room environment, our TEMA oven is optimised to work with market-leading EVA interlayers.







### Curved

Lewmar offers curved glass in both monolithic and laminated forms. Using industry-leading technology allows us to produce single radius curved glass with no expensive up-front tooling charges. More complex 3D curves can be produced on our in-house Press Bending machine.

- Roller, Press or Sag bending
- Bi-curvature Sag bent laminated glass
- Maximum size of 2500 x 3200mm and up to 19mm thick

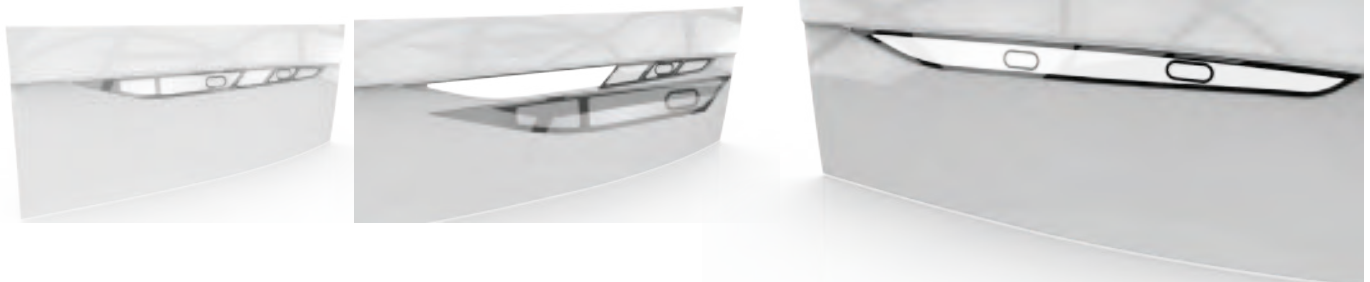
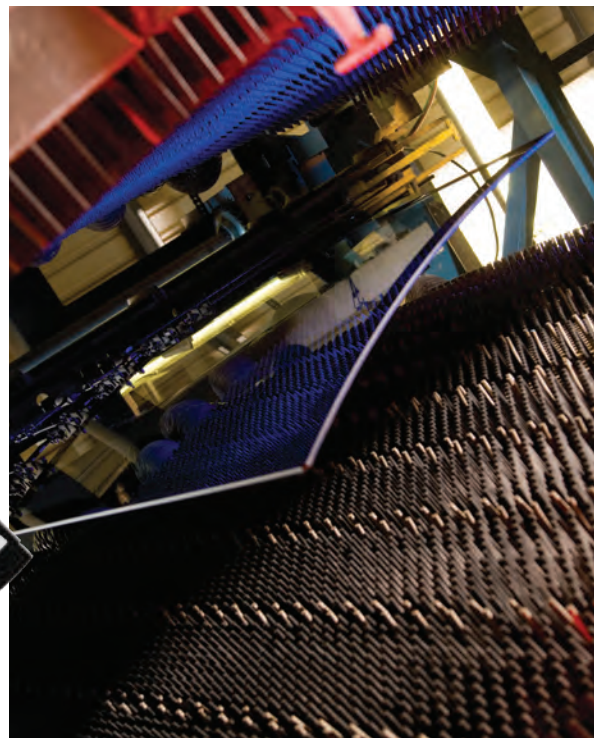

## 5. Glass & Glazing



### Pre-Installed Portlights

Lewmar have led the market in integrated, pre-mounted flush portlight solutions. This has removed the risk of installation for the boat builder and provides a clean exterior finish to the boat. A wide range of sizes, including round and rectangular portlights, in standard sizes from 112mm to 300mm. Designed to Area 1, 2B or 3 compliance and pre-approved to ISO12216.

#### PinG

Lewmar's standard integrated flush portlight. Alloy or high-impact acrylic, low-profile internal frame. Fully adjustable, glass-filled nylon hinges and handles. Available in frosted acrylic for use in the heads.

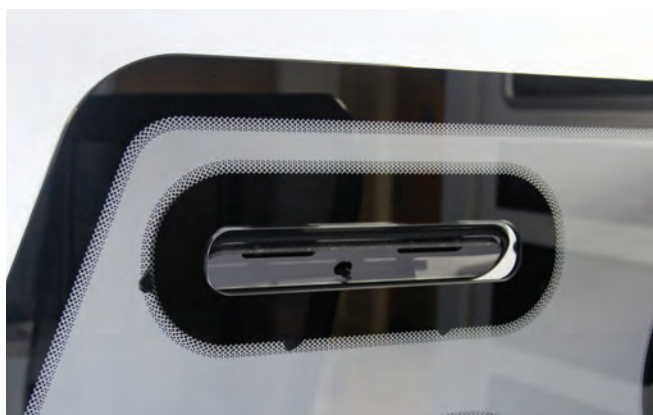

#### Super PinG

Lewmar's intermediate integrated flush portlight. Minimal visual intrusion with black alloy or high-impact acrylic low-profile internal frame. Stainless steel hinges and handles. Soft-touch rubber handle inserts.





### Stainless Super PinG

Lewmar's premium integrated flush portlight. Highly polished, full stainless steel, low-profile internal frame. Stainless steel hinges and handles. Soft-touch rubber handle inserts.

### Portlight X

Featuring a glass lens this premium portlight is available with a variety of internal finishes including highly polished stainless steel or black aluminium. Designed to meet the requirements of ISO12216 Area I or Classification Society regulations this is the portlight of choice for Superyacht applications.

- Available in monolithic or laminated lens
- Alloy, acrylic or stainless frame options



### SpunPing

Lewmar's premium flush portlight. Highly polished, full stainless steel, low-profile internal frame. Stainless steel hinges and handles. Soft-touch rubber handle inserts. The Spun Ping perfectly complements the Stainless Super Ping allowing a mix of in hull and integrated portlights to be used on the same vessel.



## 5. Glass & Glazing



### Butterfly Portlight

Lewmar's butterfly glass in glass portlight offers an integrated, flush portlight solution that seamlessly blends into the vessel's glazing. The port is supplied pre-bonded into a bespoke glass panel, saving on installation time. With its low-profile black anodised or stainless steel frame it offers a minimal interior profile to complement its flush exterior. Ideal for topside ventilation on smaller vessels.



### Glass in Glass Hatch

Lewmar's market-leading flush Glass in Glass Hatch combines our extensive knowledge in hatch design with our innovative approach to glazing. Developed as a large - yet unobtrusive - method of ventilation.





## Topside Glazing and Glass Openers

The majority of our topside glass is flat; either monolithic or laminated with a UV-inhibiting interlayer. For front screen applications, 2D or 3D curved glass is available.

Designers and builders are increasingly working to generate natural ventilation to minimise the need to run air conditioning while afloat. Modern trends in architectural design have seen a shift towards open-plan living, integrating inside and outside spaces. Recent technological advancements have led to a wide range of manual and powered doors and windows to facilitate a modern lifestyle aboard.



### Simple Slider

Market changes have led to the inclusion of opening windows on ever smaller vessels. Platforms traditionally seen on boats of over 40ft are now appearing on boats in the 18/20ft range. This has demanded the requirement for a simple, self-draining sliding window often situated in the helm area.

Lewmar offers both horizontal and vertical solutions for this application.

### Powered Vertical Pop & Slide

Typically seen on boats in the 45 to 60 foot range Lewmar's integrated Pop & Slide window allows airflow to the helm station as well as improved external visibility when docking. As with all glass products our design team will work with the customer to optimise the best solution for the vessel and the unit is supplied "ready to fit".



## 5. Glass & Glazing



### Pop & Slide

Alongside the development in flush, in-hull portlights, Lewmar has introduced a complementary range of sliding windows that are fully flush when in the closed position. These add to the sleek external styling of the vessel yet still fulfil the ever-present need for ventilation.

Typically, smaller boats are fitted with a manual version whereas boats of 50ft and above will opt for a powered window. Lewmar's powered Pop & Slide platform features a proprietary anti-trap, load sensing control solution. Each Pop & Slide is pre-tested, wired and assembled onto the glass panel for easy installation by the boat builder. This has been proven to save 4 to 5 hours of installation time per boat.



### Powered fly

Utilising Lewmar's proven aluminium and stainless steel frame designs, a range of glass powered flybridge designs have been created. Using powerful electric linear actuators, these can be powered by motion sensors or manually operated buttons.





### Vista

As electrical sliding systems become increasingly common Lewmar has developed a number of design solutions that allow a large expanse of glass to be smoothly lowered, making it possible to remove the barrier between inside and outside spaces. Powered by electric linear actuators or proven worm drive cables, designs exist to allow straight vertical drops or more complex pop in and slide systems. Typical panel sizes are between 2 and 3.5m.



### Powered Vista drop

With inside/outside space being a common theme in modern boat design we have solutions to suit a variety of installations. Working with the builder Lewmar's team will maximise opening size whilst minimising the visual intrusion of any framing. A typical installation would see the glass dropping to below deck level to allow uninterrupted panoramic views. As an additional benefit these large openings allow easy airflow which can reduce the requirement for running air conditioning systems.



## 5. Glass & Glazing



### Patio Doors

Utilising 50 years experience of working with aluminium and stainless extrusions, Lewmar have developed a wide range of Patio Door platforms. Key design features include a hard-coat anodised finish and flush-bonded glass exterior panels with minimal outer frames, providing smooth exterior doors. The sliding systems are a ball-raced stainless steel design for smooth sliding, with movement being controlled by a single-handed, integrated latch bolt design, spring-loaded to positively lock the doors in position.

We can also offer a series of integrated blind solutions, reducing OEM installation times and offering clean lines to the internal space.



### Frames

#### Alloy

A modular design allows for multiple configurations of fixed and sliding panels with minimum visual intrusion. Modern 5-axis machine centres, and common assembly components, ensure a cost-effective platform for volume-driven OEM designs.



#### Structural Alloy

Predominantly developed with the catamaran market in mind, catamaran doors provide a specific challenge in terms of overall stiffness and movement in the boat structure. The frame design offers 2 key features: a wide I beam design that offers necessary support and stability, together with a deep recess for the sliding door sections. These are hung from the top of the I beam section, allowing for smooth operation even if there is some flex in the boat structure.





### Hybrid

Conceived as an upgrade to our high volume OEM aluminium platform the Hybrid patio door platform features a 2mm highly polished stainless steel visual trim. The end result is a visually stunning door which offers the weight benefit of aluminium with the premium finish of stainless.



### Stainless

A premium offering, which utilises a folded 316 stainless steel outer frame. Using the latest folding technology we can produce a stiff, yet relatively lightweight, frame to provide an all stainless steel look, both internally and externally.



## 5. Glass & Glazing



### Door Designs

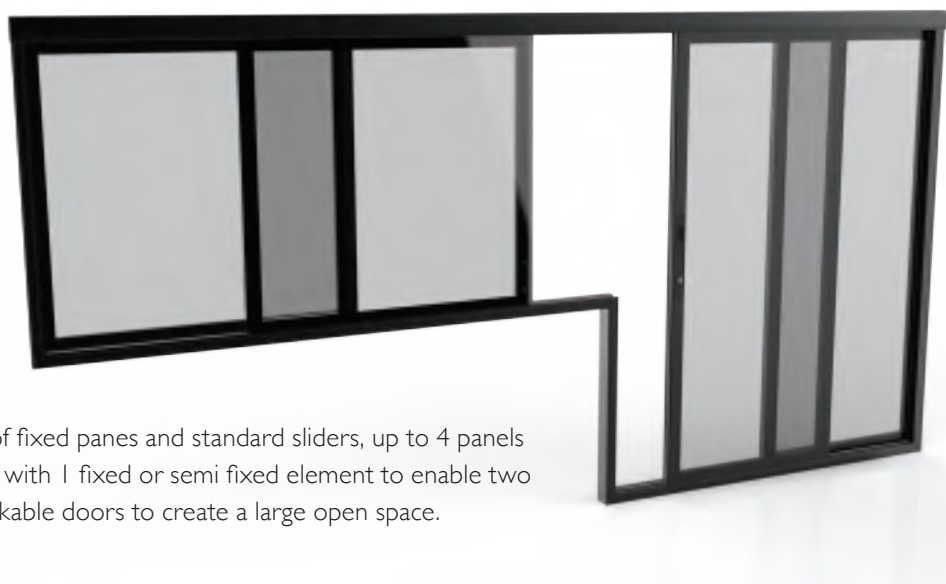

#### Sliding

Available in multiple combinations of fixed panes and standard sliders, up to 4 panels wide. A common option is 3 sliders with 1 fixed or semi fixed element to enable two possible entrance ways, or fully stackable doors to create a large open space.



#### Bi-fold

Bi-fold doors can be folded neatly to one side of the patio door maximising the opening when required. Utilising a proven triple hinge mechanism, the system provides robust support to the doors in the open and closed position.



## Patio Door Window Openers

With stern galley/bar areas becoming increasingly common in many modern designs, there is a requirement for large opening panels to be integrated in patio doors. These can be categorised by two main designs:

### Flip Up

More commonly found on smaller sport top or flybridge models. A glass panel is lifted up by either manual gas struts or electric linear actuators to allow a completely open space where food and drink can be served to the outside living space.

A minimalist alloy frame provides a stiff structure that remains lightweight.



### Powered Drop

More commonly found on boats above 50 feet. Lewmar offer both a framed and frameless solution where the glass disappears vertically into the lower door section. This in turn is often integrated into the boat's furniture. A smooth, worm-wheel cable drive system ensures reliable and quiet operation.

## Gullwing Door

Opening and folding upwards the Gullwing door offers an elegant solution where space constraints don't allow a traditional Flip Up window to be installed. The design allows for easy installation by the yard via a variety of fastening methods. A typical Gullwing would allow easy access from saloon out onto the side decks.



## 5. Glass & Glazing



### Roof Glazing

#### Fixed Glass Roof

Available as standard fit, this is a bonded, fixed panel which is fully interchangeable with the powered roof, ideal for late configuration into production. The fixed panel is designed to keep the basic package price of the boat competitive, with the option of an owner upgrade to the powered solution



#### Sliding Roof

With a depth of experience in bending, sealing and shaping aluminium hatch platforms, Lewmar has developed a full range of sliding glass sunroof systems. Three standard sizes are available with a 2D curve. Bespoke sizing and custom 3D curved solutions are also possible in low batch runs. A proven electrical worm wheel drive system ensures smooth operation.



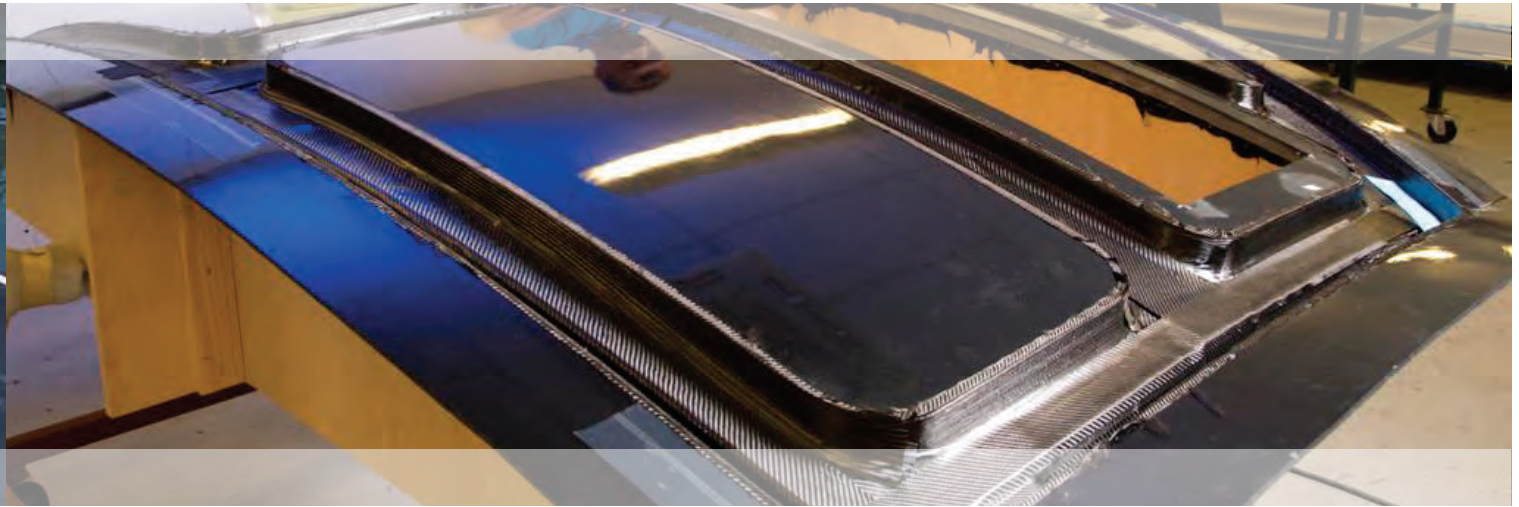

### Carbon Shutter

Using our in house carbon facility together with the best materials and cutting edge FEA we're able to offer carbon and glass roof shutters of the highest quality. Each roof frame is specifically designed and engineered for that particular boat model and coated in a clear lacquer to emphasise the outstanding finish.

- Bespoke panels and drive systems
- Layup of tools in resin-infused carbon
- Component panels in pre-preg
- Top surface glass or carbon

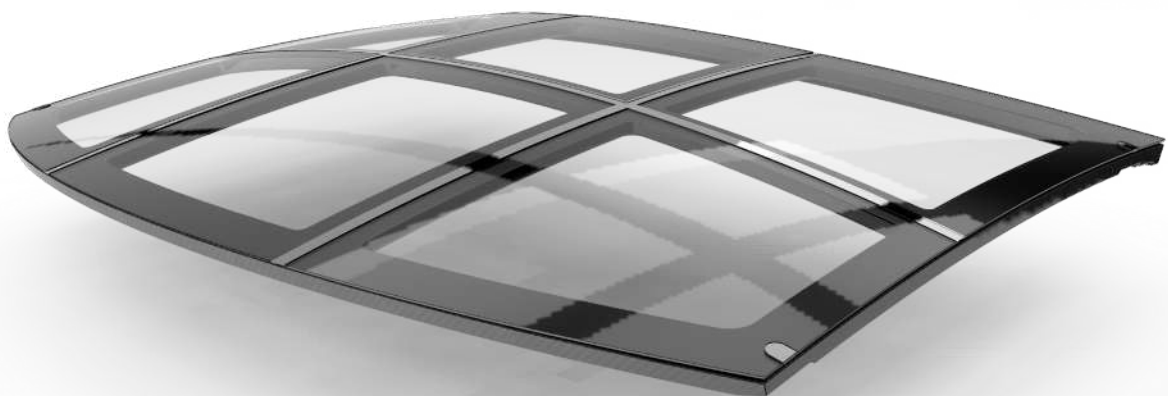

# LEWMAR®

## TrendMarine

A Lippert Components Company



[www.trendmarine.com](http://www.trendmarine.com)



## Trend Marine Glass and Glazing

For more than 40 years Trend Marine have been supplying high quality marine glass and glazing solutions to Motor and Sail vessels ranging from 7m to 130m. Now that Trend Marine is a subsidiary business of Lewmar we can offer a wider range of products than ever before from our two UK manufacturing facilities.

Trend's extensive glazing portfolio includes: flat and curved thermally toughened glass, sag bent chemically toughened curved panels, laminated glass, integrated flush portlights in glass, carbon powered electric shutter roofs, sliding hardtop roofs, fabric soft-top systems, framed and unframed flybridge screens as well as patio doors & companionway doors in both stainless steel and aluminium.

Working in collaboration with the industry's most prestigious designers, OEMs and Superyacht builders we offer cutting edge product solutions to suit each individual project. In recent times a key design driver has been the increasing requirement for fresh air in the cabin space to be available at the touch of a button. These powered openers now allow boat owners to enjoy combined inside-outside space with the added benefit of uninterrupted panoramic views.

Our in house compliance team have many years of experience working with the World's leading classification societies and notified bodies. They will assist with optimising your glass specification and thickness within the framework of the relevant regulations whether to Class or ISO12216. If any testing is required this can be carried out on site using our calibrated and approved test rigs.

From our base in Norfolk, UK we can despatch innovative glazing solutions World-wide.



We recognise that refits often require special attention and that speed of response is key. Every refit is individually project managed in-house to ensure each phase progresses as quickly and smoothly as possible. We can offer the complete package from survey through design to build, delivery and finally installation.

For boats where CAD data is unreliable or unavailable the first step is for our team to laser scan survey on site capturing size, shape and curvature of the glass before designing the replacements. Once the glass is built and delivered our experienced glass fitting professionals will attend to carry out the installation



## Thermally Toughened Laminated Glass

---

Benefits of Trend Marine toughened and laminated glass:

Choose the best options in interlayer technology  
- EVA or DuPont Sentry Glass

Strength of interlayer options means significant weight savings can be achieved compared to traditional glass specifications.

- Flat or curved
- UV protection
- Thermal insulation
- Switchable options
- Coloured film options
- Heated options

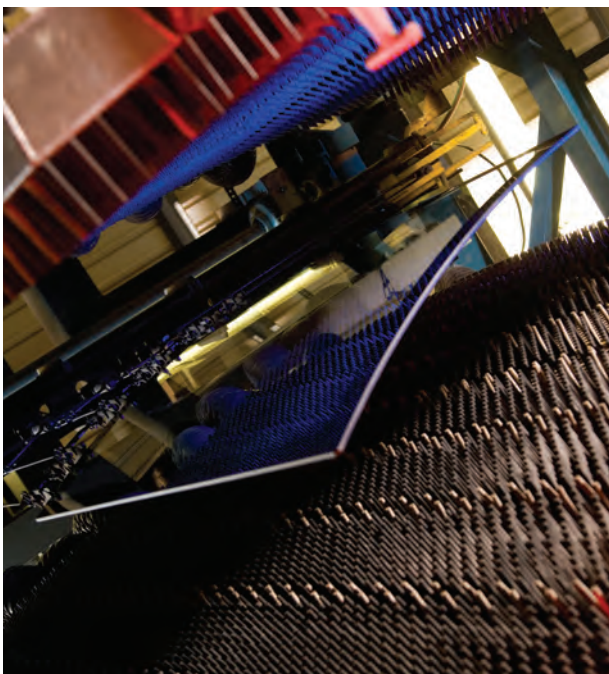

## Sag Bent Chemically Toughened Laminated Glass

---

Typically used for large front screens or complex shapes where ultimate optical clarity is required. The glass is initially sag bent over precision engineered stainless tooling before being chemically toughened. Finally the plies are laminated together using the finest interlayers.





## Curved Glazing

---

Trend Marine have two high capacity thermal press bend toughening lines set up for batch production. Typically these are utilised for windscreen manufacture on boats up to 100 feet and offer a cost effective solution to OEM customers.

Our sag bending furnace is utilised when a Superyacht level of finish is required. This technology allows glass to be formed to a tight radius with double curvature and conicity.



## Other Glazing Solutions

---

### Roofs

Individually designed sliding roof solutions are available in a range of materials including carbon fibre.

### Doors

Electric and manual patio doors are tailored to each yacht's needs. Other door solutions include companionway doors and watertight doors.

### Windows

Electric and manual opening side window solutions are designed to offer functionality and style.





LIPPERT  
COMPONENTS®



[www.lippertcomponents.eu](http://www.lippertcomponents.eu)





## Lippert Components **Bed Systems**

### New for the marine market

Our powered bed systems were originally designed, engineered and built in Italy by our colleagues at Lippert Components. With subtle tweaks by Lewmar to suit the marine environment you can now configure your cabin for sleeping, reading, or day use with the touch of a button. A powered bed system can fundamentally change the use of interior space aboard.

Utilizing a unique nylon strap-based system the modular platform is adaptable to suit a broad range of sail and motorboat applications including saloons, guest rooms and crew cabins. The straps retract into the bed base, concealing the lifting system while in the retracted position and allowing OEMs a new found freedom in floorplan design. The virtually silent operation is controlled by a single motor to raise and lower the bed. The system can be customized in both size and configuration to ensure optimum space utilization.

## Smart Bunk Bed

### Electronic Bed Lifting System for Bunk Beds

Provides up and down lift for the two bunk beds. This configuration is ideal for use in crew cabins where space is always at a premium.

- Unlimited stroke
- Powerful motor with integrated encoder
- Manual override in case of electrical failure
- Delivered complete with mounting cables
- 400 kg maximum loading capacity (static)





## Two-In-One

Electric Bed Lifting System with extendable bed frame

- Designed for vertical lifting and lowering movement
- Locks horizontally or in slant position under the ceiling
- Maximum extension approximately 80% of the width of the bed base
- Electrically operated
- Lightweight, quiet system
- Includes manual emergency system
- Maximum carrying capacity 300 kg





## 6. Winch



Lewmar winches are designed with both cruising sailors and racing crews in mind. The EVO® range of winches meets the needs of sailors and boat builders with a perfect blend of looks, functionality, and reliability. We have a range of new race-inspired winches and, for short-handed crews, the revolutionary REVO® backwinding winch makes sail handling a breeze.

Constant evolution results in Lewmar winches being fitted to numerous sailing boats: from high-volume OEMs to some of the world's biggest superyachts.

# 6. Winch

## Winch Selection Guide

Efficient sail handling begins with the selection of the correct winch. To help you choose your desired winch, the chart below is designed as a quick reference to match application, yacht size and winch. Cross reference your yacht size (for masthead rigs) or sail area (fractional rigs) with application, to ascertain the correct winch. You can also send your deck and sail plans to your Lewmar representative, they will be pleased to make individual recommendations. REMEMBER runner winch and mainsheet winch selection depends on the purchase system fitted, and expected loads. Dynamic sail loads can easily increase the loads dramatically. Multihulls generally have a higher righting moment than monohulls of equivalent lengths, resulting in higher dynamic loading, therefore, winch size needs to be larger – consult your Lewmar representative or rigger for further guidance.

### Sail Area

APPLICATION	M FT	BOAT LENGTH OVERALL																					
		6.1-7.6 20-25		7.6-8.8 25-29		8.8-10.1 29-33		10.1-10.7 33-35		10.7-11.3 35-37		11.3-11.9 37-39		11.9-12.5 39-41		12.8-14.6 42-48		14.6-16.8 48-55		16.8-18.9 55-62		18.9-21.6 62-71	
GENOA (FT <sup>2</sup> /M <sup>2</sup> )		200	19	300	28	350	33	470	44	550	51	600	56	750	70	900	84	1500	139	1900	177	2300	214
SPINNAKER (FT <sup>2</sup> /M <sup>2</sup> )		300	28	400	37	600	56	800	74	1000	93	1200	111	1400	130	1600	149	3000	279	3800	353	4600	427
MAIN (FT <sup>2</sup> /M <sup>2</sup> )		120	11	150	14	180	17	210	20	230	21	260	24	300	28	350	33	750	70	875	81	1000	93

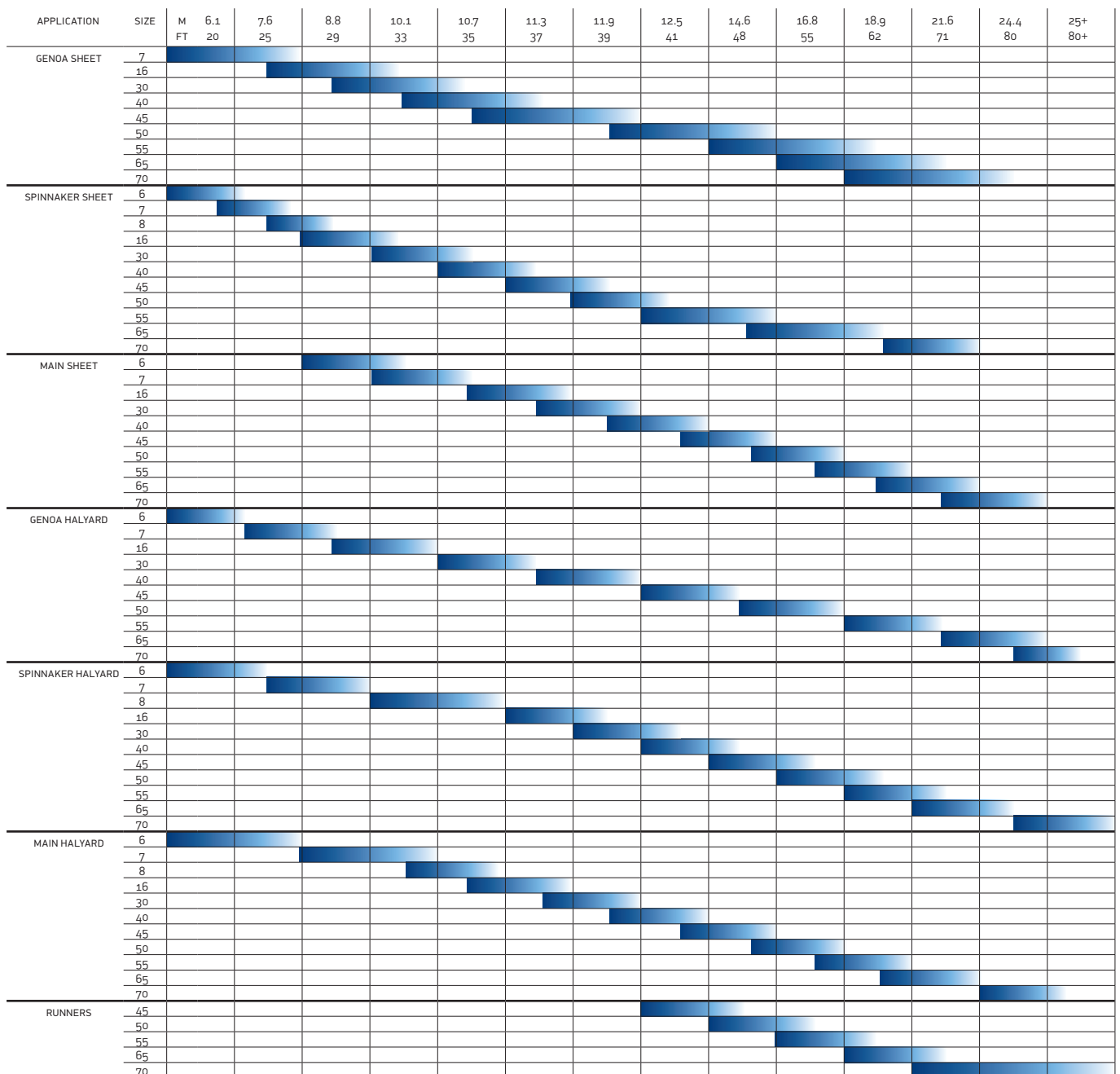

LIGHTER SHADING REPRESENTS THE UPPER LIMIT OF THE MODEL. IF IN DOUBT, MOVE UP A MODEL.

USE AS GUIDE ONLY

## The Lewmar Winch Range



### Page 216 EVO® Winch

- Available from size 6 to size 80
- Easy Servicing – no tools required
- Convertable to electric from size 40 up
- Choice of multiple styles and finishes
- 7 year warranty



### Page 219 Electric Winches

- Purchase complete or retrofit
- Push button power control
- Features manual override



### Page 226 Ocean Self-Tailing Winches

- Easy Servicing – no tools required
- Convertable to electric from size 40 up
- Available in size 16 to size 65



### Page 230 Hydraulic Winches

- Ideal for craft over 15m (50ft)
- Minimal space and weight
- Quiet operation
- Features manual override



### Page 232 REVO™ Winch

- Available in five sizes (40, 45, 50, 55, 65)
- Uses proven winch internals so retains all the benefits of the EVO® Winch
- Most suitable for genoa sheeting



### Page 238 Custom Winches

- Cutting edge performance
- Wide range of finish and style
- Superior strength
- Easy to service



### Page 244 Racing Pedestal and GP Winches

- Lightweight I-beam carbon shell
- Unique belt drive ensures maximum efficiency
- Removable pedestal option for fast cruising market



### Page 248 Line Management System

- Up to 25% lighter than previous models
- Up to 3 speed options
- Unique stowing system ensures low line tension
- Emergency high-load release feature



### Page 251 Winch Handles

- Award-winning OneTouch offers easy one-handed removal
- Lightweight, forged construction
- PowerGrip makes initial one-handed fast cranking easy
- Corrosion resistant

## 6. Winch



### EVO® Self-Tailing Winches

An evolution of the renowned Lewmar Ocean winch, the EVO® Self-Tailing Winch draws on a wealth of design and manufacturing experience to produce a state-of-the-art product. With a wide choice of sizes and styles, there is a versatile EVO® for any style or application.

- **Simple Servicing**

No tools are required to service a Lewmar EVO® winch. Simply unscrew the top cap with your fingers to remove the drum and provide access to the gear train.

- **Multiple Styles and Finishes**

EVO® winches are available in black or grey alloy and chrome bronze for the cruising sailor. Manual winches feature single speed or two speed, while size 40 to size 80 are available with electric or hydraulic operation.

- **Wave Spring Jaw and Feeder Arm**

The integrated, investment-cast, stainless steel feeder arm completely covers the top of the winch, preventing a rope trap above the Wavespring jaws. The feeder arm position can be adjusted to smoothly feed the rope out of the jaws and into the cockpit.

- **Engineering Excellence**

For Lewmar customers, there is no such thing as “just a winch”. That’s because inside every winch you will find materials developed over many years, designed using the latest techniques, and machined using CNC equipment. When we machine the winches we are looking for the maximum in efficiency, durability, and strength to weight ratio.

- **Electric Winches (40 and above)**

Whatever sailing you do, short handed or long distance cruising, the decision to install electric winches or upgrade your existing winches with one of our conversion kits is simple.

- **7-Year Warranty**

We are so confident about the quality of the EVO® winch range that we are supporting it with a 7-year warranty.







### Expert Advice

When installing a winch, Lewmar recommends the winch must be mounted on a flat surface and that the rope enters the drum at an angle of 5° to 10° to the base axis of the winch. This angle can be achieved by using a base wedge when mounting the winch.

### Dimensions Diagram EVO® Self-Tailing Winch

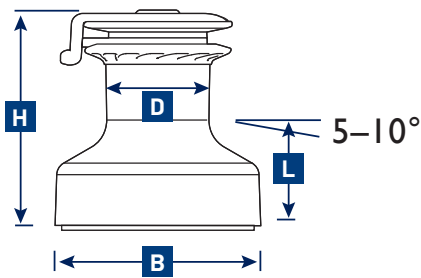

### Mounting Instructions

15ST	5 X M6 (1/4 IN) C'SK HEAD SCREWS ON 94MM (3 <sup>7</sup> / <sub>10</sub> IN) PCD
30ST	5 X M6 (1/4 IN) C'SK HEAD SCREWS ON 113MM (4 <sup>5</sup> / <sub>32</sub> IN) PCD
40ST	5 X M6 (1/4 IN) C'SK HEAD SCREWS ON 121MM (4 <sup>3</sup> / <sub>4</sub> IN) PCD
45ST	5 X M8 (5/16 IN) C'SK HEAD SCREWS ON 136MM (5 <sup>11</sup> / <sub>32</sub> IN) PCD
50ST	5 X M8 (5/16 IN) C'SK HEAD SCREWS ON 150MM (5 <sup>29</sup> / <sub>32</sub> IN) PCD
55ST	6 X M8 (5/16 IN) C'SK HEAD SCREWS ON 165MM (6 <sup>1</sup> / <sub>2</sub> IN) PCD
65ST	5 X M10 (3/8 IN) C'SK HEAD SCREWS ON 184MM (7 <sup>1</sup> / <sub>4</sub> IN) PCD
70-70/3ST	6 X M10 (3/8 IN) C'SK HEAD SCREWS ON 241MM (9 <sup>1</sup> / <sub>2</sub> IN) PCD
80-80/3ST	6 X M10 (3/8 IN) C'SK HEAD SCREWS ON 241MM (9 <sup>1</sup> / <sub>2</sub> IN) PCD

### EVO® Self-Tailing Winch Specifications

PART NO	MODEL	FINISH	GEAR RATIO		POWER RATIO		WLL		WEIGHT		D DRUM DIA		B BASE DIA		H HEIGHT		L LINE ENTRY		LINE SIZE	
			1ST	2ND	1ST	2ND	KG	LB	KG	LB	MM	IN	MM	IN	MM	IN	MM	IN	MM	IN
49515055	15ST	ALLOY BLACK	2:1	-	15.8:1	-	570	1257	2.6	5.7	66.8	2 <sup>5</sup> / <sub>8</sub>	121	4 <sup>3</sup> / <sub>4</sub>	119	4 <sup>11</sup> / <sub>16</sub>	58	2 <sup>5</sup> / <sub>16</sub>	8-12	5/16-1/2
49515057	15ST	ALLOY GREY	2:1	-	15.8:1	-	570	1257	2.6	5.7	66.8	2 <sup>5</sup> / <sub>8</sub>	121	4 <sup>3</sup> / <sub>4</sub>	119	4 <sup>11</sup> / <sub>16</sub>	58	2 <sup>5</sup> / <sub>16</sub>	8-12	5/16-1/2
49515056	15ST	CHROME BRONZE	2:1	-	15.8:1	-	570	1257	3.9	8.6	66.8	2 <sup>5</sup> / <sub>8</sub>	121	4 <sup>3</sup> / <sub>4</sub>	119	4 <sup>11</sup> / <sub>16</sub>	58	2 <sup>5</sup> / <sub>16</sub>	8-12	5/16-1/2
49530055	30ST	ALLOY BLACK	2:1	4.2:1	13.8:1	29.2:1	685	1510	4	8.8	74	2 <sup>15</sup> / <sub>16</sub>	138	5 <sup>7</sup> / <sub>16</sub>	145.85	5 <sup>3</sup> / <sub>4</sub>	69	2 <sup>11</sup> / <sub>16</sub>	8-12	5/16-1/2
49530057	30ST	ALLOY GREY	2:1	4.2:1	13.8:1	29.2:1	685	1510	4	8.8	74	2 <sup>15</sup> / <sub>16</sub>	138	5 <sup>7</sup> / <sub>16</sub>	145.85	5 <sup>3</sup> / <sub>4</sub>	69	2 <sup>11</sup> / <sub>16</sub>	8-12	5/16-1/2
49530056	30ST	CHROME BRONZE	2:1	4.2:1	13.8:1	29.2:1	685	1510	5.4	11.9	74	2 <sup>15</sup> / <sub>16</sub>	138	5 <sup>7</sup> / <sub>16</sub>	145.85	5 <sup>3</sup> / <sub>4</sub>	69	2 <sup>11</sup> / <sub>16</sub>	8-12	5/16-1/2
49540055	40ST	ALLOY BLACK	1.9:1	5.8:1	13.2:1	40.2:1	795	1753	4.9	10.7	74	2 <sup>15</sup> / <sub>16</sub>	148	5 <sup>13</sup> / <sub>16</sub>	158.5	6 <sup>1</sup> / <sub>4</sub>	79	3 <sup>1</sup> / <sub>8</sub>	8-12	5/16-1/2
49540057	40ST	ALLOY GREY	1.9:1	5.8:1	13.2:1	40.2:1	795	1753	4.9	10.7	74	2 <sup>15</sup> / <sub>16</sub>	148	5 <sup>13</sup> / <sub>16</sub>	158.5	6 <sup>1</sup> / <sub>4</sub>	79	3 <sup>1</sup> / <sub>8</sub>	8-12	5/16-1/2
49540056	40ST	CHROME BRONZE	1.9:1	5.8:1	13.2:1	40.2:1	795	1753	6.5	14.3	74	2 <sup>15</sup> / <sub>16</sub>	148	5 <sup>13</sup> / <sub>16</sub>	158.5	6 <sup>1</sup> / <sub>4</sub>	79	3 <sup>1</sup> / <sub>8</sub>	8-12	5/16-1/2
49545055	45ST	ALLOY BLACK	2.4:1	7.6:1	13.9:1	44.8:1	1200	2646	7.1	15.6	87	3 <sup>7</sup> / <sub>16</sub>	168	6 <sup>5</sup> / <sub>8</sub>	177.7	7	84	3 <sup>5</sup> / <sub>16</sub>	8-14	5/16-9/16
49545057	45ST	ALLOY GREY	2.4:1	7.6:1	13.9:1	44.8:1	1200	2646	7.1	15.6	87	3 <sup>7</sup> / <sub>16</sub>	168	6 <sup>5</sup> / <sub>8</sub>	177.7	7	84	3 <sup>5</sup> / <sub>16</sub>	8-14	5/16-9/16
49545056	45ST	CHROME BRONZE	2.4:1	7.6:1	13.9:1	44.8:1	1200	2646	9.7	21.3	87	3 <sup>7</sup> / <sub>16</sub>	168	6 <sup>5</sup> / <sub>8</sub>	177.7	7	84	3 <sup>5</sup> / <sub>16</sub>	8-14	5/16-9/16
49550055	50ST	ALLOY BLACK	2.6:1	9:1	13.9:1	48.6:1	1250	2756	9	19.8	93	3 <sup>5</sup> / <sub>8</sub>	181	7 <sup>1</sup> / <sub>8</sub>	197	7 <sup>3</sup> / <sub>4</sub>	90	3 <sup>1</sup> / <sub>2</sub>	8-14	5/16-9/16
49550057	50ST	ALLOY GREY	2.6:1	9:1	13.9:1	48.6:1	1250	2756	9	19.8	93	3 <sup>5</sup> / <sub>8</sub>	181	7 <sup>1</sup> / <sub>8</sub>	197	7 <sup>3</sup> / <sub>4</sub>	90	3 <sup>1</sup> / <sub>2</sub>	8-14	5/16-9/16
49550056	50ST	CHROME BRONZE	2.6:1	9:1	13.9:1	48.6:1	1250	2756	12.3	27	93	3 <sup>5</sup> / <sub>8</sub>	181	7 <sup>1</sup> / <sub>8</sub>	197	7 <sup>3</sup> / <sub>4</sub>	90	3 <sup>1</sup> / <sub>2</sub>	8-14	5/16-9/16
49555055	55ST	ALLOY BLACK	2.8:1	11.2:1	13.8:1	54:1	1480	3263	12.2	26.9	105	4 <sup>1</sup> / <sub>8</sub>	205	8 <sup>1</sup> / <sub>16</sub>	233	9 <sup>11</sup> / <sub>32</sub>	115	4 <sup>1</sup> / <sub>2</sub>	8-16	5/16-5/8
49555057	55ST	ALLOY GREY	2.8:1	11.2:1	13.8:1	54:1	1480	3263	12.2	26.9	105	4 <sup>1</sup> / <sub>8</sub>	205	8 <sup>1</sup> / <sub>16</sub>	233	9 <sup>11</sup> / <sub>32</sub>	115	4 <sup>1</sup> / <sub>2</sub>	8-16	5/16-5/8
49555056	55ST	CHROME BRONZE	2.8:1	11.2:1	13.8:1	54:1	1480	3263	18	39.6	105	4 <sup>1</sup> / <sub>8</sub>	205	8 <sup>1</sup> / <sub>16</sub>	233	9 <sup>11</sup> / <sub>32</sub>	115	4 <sup>1</sup> / <sub>2</sub>	8-16	5/16-5/8
49565055	65ST	ALLOY BLACK	3.1:1	14.8:1	13.4:1	64:1	1700	3748	16.6	36.5	118	4 <sup>5</sup> / <sub>8</sub>	228	9	251	9 <sup>7</sup> / <sub>8</sub>	119	4 <sup>1</sup> / <sub>16</sub>	8-18	5/16-1 <sup>1</sup> / <sub>16</sub>
49565057	65ST	ALLOY GREY	3.1:1	14.8:1	13.4:1	64:1	1700	3748	16.6	36.5	118	4 <sup>5</sup> / <sub>8</sub>	228	9	251	9 <sup>7</sup> / <sub>8</sub>	119	4 <sup>1</sup> / <sub>16</sub>	8-18	5/16-1 <sup>1</sup> / <sub>16</sub>
49565056	65ST	CHROME BRONZE	3.1:1	14.8:1	13.4:1	64:1	1700	3748	23.8	52.4	118	4 <sup>5</sup> / <sub>8</sub>	228	9	251	9 <sup>7</sup> / <sub>8</sub>	119	4 <sup>1</sup> / <sub>16</sub>	8-18	5/16-1 <sup>1</sup> / <sub>16</sub>

## 6. Winch



### Custom EVO® Winches

Lewmar Evo winches extend to size 80, 3 speed.

#### Evo® Winch Electric Conversion Kit

- Upgrade your manual winch to an electric model with the Evo upgrade kit.
- The kit contains all you need to convert to an electric winch.
- Option for sizes 40 to 50 to have the contactor pre-mounted to the motor gearbox removing any complicated wiring for a tidier and easier installation. It only requires connecting the battery and the switch supplied.



WINCH SIZE	12V CONVERSION KIT CONTACTOR PRE-MOUNTED	12V CONVERSION KIT WITH SEPARATE CONTACTOR
40ST	48540301	48540300
45ST	48545301	48545300
50ST	48550301	48550300
55ST	-	48555300

Kit includes:

1

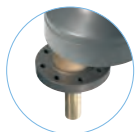

Power Drive

2



Motor Gearbox and Contactor

3



Circuit Breaker p234

4



Switch p235

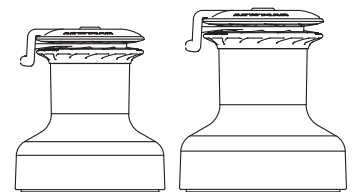

70

80

#### Custom EVO® Self-Tailing Winch Specifications

PART NO	MODEL	FINISH	GEAR RATIO			POWER RATIO		WLL		WEIGHT		D DRUM DIA		B BASE DIA		H HEIGHT		L LINE ENTRY		LINE SIZE		
			1ST	2ND	3RD	1ST	2ND	KG	LB	KG	LB	MM	IN	MM	IN	MM	IN	MM	IN	MM	IN	
49570055	70ST	ALLOY BLACK		5.8	18.8		20.9	67.6	3000	6600	20.5	45.1	141	5 9/16	282	11 1/8	277	10 7/8	142	5 5/8	12 - 22	1/2 - 7/8
49570057	70ST	ALLOY GREY		5.8	18.8		20.9	67.6	3000	6600	20.5	45.1	141	5 9/16	282	11 1/8	277	10 7/8	142	5 5/8	12 - 22	1/2 - 7/8
49570056	70ST	CHROME BRONZE		5.8	18.8		20.9	67.6	3000	6600	30.9	67.98	141	5 9/16	282	11 1/8	277	10 7/8	142	5 5/8	12 - 22	1/2 - 7/8
49570065	70/3ST	ALLOY BLACK	2.8	8	19.3	9.9	29.1	69.3	3000	6600	33	72.6	141	5 9/16	282	11 1/8	321	12 5/8	142	5 5/8	12 - 22	1/2 - 7/8
49570067	70/3ST	ALLOY GREY	2.8	8	19.3	9.9	29.1	69.3	3000	6600	33	72.6	141	5 9/16	282	11 1/8	321	12 5/8	142	5 5/8	12 - 22	1/2 - 7/8
49570066	70/3ST	CHROME BRONZE	2.8	8	19.3	9.9	29.1	69.3	3000	6600	37	81.4	141	5 9/16	282	11 1/8	321	12 5/8	142	5 5/8	12 - 22	1/2 - 7/8
CONTACT LEWMAR	80ST	ALLOY BLACK		8	27		23	77	3500	7700	39	85.8	178	7	294	11 5/8	321	12 5/8	174	6 7/8	12 - 22	1/2 - 7/8
	80ST	ALLOY GREY		8	27		23	77	3500	7700	39	85.8	178	7	294	11 5/8	321	12 5/8	174	6 7/8	12 - 22	1/2 - 7/8
	80ST	CHROME BRONZE		8	27		23	77	3500	7700	42.8	94.16	178	7	294	11 5/8	321	12 5/8	174	6 7/8	12 - 22	1/2 - 7/8
49580065	80/3ST	ALLOY BLACK	2.8	8	27	7.9	23	77	3500	7700	43	94.6	178	7	294	11 5/8	321	12 5/8	174	6 7/8	12 - 22	1/2 - 7/8
49580067	80/3ST	ALLOY GREY	2.8	8	27	7.9	23	77	3500	7700	43	94.6	178	7	294	11 5/8	321	12 5/8	174	6 7/8	12 - 22	1/2 - 7/8
49580066	80/3ST	CHROME BRONZE	2.8	8	27	7.9	23	77	3500	7700	44.5	97.9	178	7	294	11 5/8	321	12 5/8	174	6 7/8	12 - 22	1/2 - 7/8

## EVO® Electric Winches

A Self-Tailing EVO® Winch that works at the push of a button is exactly what you will find with Lewmar's electric winch range. Whether you buy an electrically-operated winch complete or retrofit the compact electric motor/controller unit, the electric EVO® provides improved sail control.

- Push button power
- Quiet operation
- Manual override
- Easy to install
- Featuring powerful series wound motors
- Choice of two levels of control: E Series or Electric Load Sensing (ELS)

### EVO® Electric Winch Kit

The kit contains all you need to install your electric winch.

**1** Deck unit and motor gearbox



**3** Contactor or Control box



**3** Circuit breaker



**4** Switch



### EVO® Electric Winch Kits

PART NUMBER		DESCRIPTION
12 VOLTS	24 VOLTS	
49540219	-	40EST ALLOY BLACK ELECTRIC WINCH KIT
49540218	-	40EST CHROME BRONZE ELECTRIC WINCH KIT
49540217	-	40EST ALLOY GREY ELECTRIC WINCH KIT
49545219	-	45EST ALLOY BLACK ELECTRIC WINCH KIT
49545218	-	45EST CHROME BRONZE ELECTRIC WINCH KIT
49545217	-	45EST ALLOY GREY ELECTRIC WINCH KIT
49550219	-	50EST ALLOY BLACK ELECTRIC WINCH KIT
49550218	-	50EST CHROME BRONZE ELECTRIC WINCH KIT
49550217	-	50EST ALLOY GREY ELECTRIC WINCH KIT
49555210	49555230	55EST ALLOY BLACK ELECTRIC WINCH KIT
49555201	49555221	55EST CHROME BRONZE ELECTRIC WINCH KIT
49555200	49555220	55EST ALLOY GREY ELECTRIC WINCH KIT
49565210	49565230	65EST ALLOY BLACK ELECTRIC WINCH KIT
49565201	49565221	65EST CHROME BRONZE ELECTRIC WINCH KIT
49565200	49565220	65EST ALLOY GREY ELECTRIC WINCH KIT
-	49570230	70EST ALLOY BLACK ELECTRIC WINCH KIT
-	49570221	70EST CHROME BRONZE ELECTRIC WINCH KIT
-	49570220	70EST ALLOY GREY ELECTRIC WINCH KIT
-	49570211	70/3EST ALLOY BLACK ELECTRIC WINCH KIT
-	49570212	70/3EST CHROME BRONZE ELECTRIC WINCH KIT
-	49570213	70/3EST ALLOY GREY ELECTRIC WINCH KIT
-	49580230	80EST ALLOY BLACK ELECTRIC WINCH KIT
-	49580221	80EST CHROME BRONZE ELECTRIC WINCH KIT
-	49580220	80EST ALLOY GREY ELECTRIC WINCH KIT
-	49580211	80/3EST ALLOY BLACK ELECTRIC WINCH KIT
-	49580212	80/3EST CHROME BRONZE ELECTRIC WINCH KIT
-	49580213	80/3EST ALLOY GREY ELECTRIC WINCH KIT

# 6. Winch

## Specify Your Own Electric Winch

### 1 Deck Unit



### 2 Motor Gearbox



### 3 Contactor/Control Box



Circuit Breaker  
p234

### 4 Accessories



Switch  
p235

### 1 Electric Winch Deck Unit

#### Electric Winch

PART NUMBER	MODEL	FINISH	WEIGHT	
			KG	LB
48540210	40 EST	ALLOY BLACK	17.8	39.3
48540201	40 EST	CHROME	19.5	43.0
48540200	40 EST	ALLOY GREY	17.8	39.3
48545210	45 EST	ALLOY BLACK	22.1	48.6
48545201	45 EST	CHROME	24.6	54.1
48545200	45 EST	ALLOY GREY	22.1	48.6
48550210	50 EST	ALLOY BLACK	24.7	54.3
48550201	50 EST	CHROME	28.1	61.8
48550200	50 EST	ALLOY GREY	24.7	54.3
48555210	55 EST	ALLOY BLACK	29.0	63.8
48555201	55 EST	CHROME	34.8	76.5
48555200	55 EST	ALLOY GREY	29.0	63.8
48565210	65 EST	ALLOY BLACK	33.6	73.9
48565201	65 EST	CHROME	40.8	89.7
48565200	65 EST	ALLOY GREY	33.6	73.9

#### Custom Electric Winch

PART NUMBER	MODEL	FINISH	WEIGHT	
			KG	LB
48570210	70 EST	ALLOY BLACK	42.0	92.6
48570201	70 EST	CHROME	48.8	107.6
48570200	70 EST	ALLOY GREY	42.0	92.6
48570208	70/3 EST	ALLOY BLACK	48.0	105.8
48570207	70/3 EST	CHROME	54.8	120.8
48570206	70/3 EST	ALLOY GREY	48.0	105.8
48580210	80 EST	ALLOY BLACK	49.3	108.7
48580201	80 EST	CHROME	55.3	121.9
48580200	80 EST	ALLOY GREY	49.3	108.7
48580208	80/3 EST	ALLOY BLACK	51.3	113.1
48580207	80/3 EST	CHROME	57.3	126.3
48580206	80/3 EST	ALLOY GREY	51.3	113.1

NOTES: WEIGHTS SHOWN ABOVE INCLUDES THE WEIGHT OF MOTOR GEARBOX & CONTROL BOX.

### 2 Motor Gearbox

PART NUMBER	DESCRIPTION	MOTOR (Watt)								
			40ST	45ST	50ST	55ST	65ST	70-70/3	80-80/3	
48000116	40-50 12V M/GBOX ASSY	700	•	•	•					
48000117	40-50 24V M/GBOX ASSY	900	•	•	•					
48000075	55-65 12V M/GBOX ASSY	1600				•	•			
48000076	55-65 24V M/GBOX ASSY	2000				•	•			
48000077	70-80 12V M/GBOX ASSY	1600						•	•	
48000078	70-80 24V M/GBOX ASSY	2000						•	•	



#### Electric motor including contactor

Lewmar can also supply motor gearboxes with the E-series contactor pre-mounted. This convenient solution removes any complicated wiring for an easier installation. The complete wiring is reduced to connecting the battery and the switch.

PART NUMBER	DESCRIPTION	MOTOR (Watt)			
			40ST	45ST	50ST
48000211	12V PRE-WIRED M/GBOX	700	•	•	•
48000212	24V PRE-WIRED M/GBOX	900	•	•	•



## Electric Winch Dimensions

When installing a winch, Lewmar recommends the winch be mounted on a level surface and that the rope enters the drum at an angle of 5° to 10° to the base axis of the winch. This angle can be achieved by using a base wedge when mounting the winch.

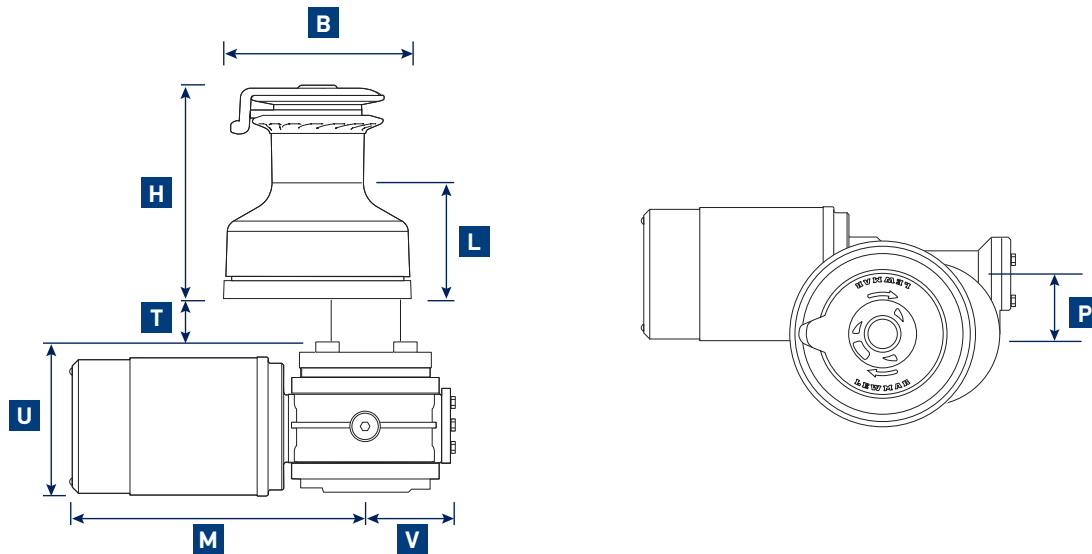

WINCH SIZE	H HEIGHT		L LINE ENTRY		M		P		T		U		V		B BASE DIA	
	MM	IN	MM	IN	MM	IN	MM	IN	MM	IN	MM	IN	MM	IN	MM	IN
40EST	175	6 <sup>9</sup> / <sub>10</sub>	95	3 <sup>49</sup> / <sub>64</sub>	239	9 <sup>25</sup> / <sub>64</sub>	50	1 <sup>31</sup> / <sub>32</sub>	34.4	1 <sup>23</sup> / <sub>64</sub>	120.7	2 <sup>3</sup> / <sub>4</sub>	72.5	2 <sup>55</sup> / <sub>64</sub>	154	6 <sup>1</sup> / <sub>16</sub>
45EST	194	7 <sup>5</sup> / <sub>8</sub>	100	3 <sup>61</sup> / <sub>64</sub>	239	9 <sup>25</sup> / <sub>64</sub>	50	1 <sup>31</sup> / <sub>32</sub>	64.4	2 <sup>17</sup> / <sub>32</sub>	120.7	2 <sup>3</sup> / <sub>4</sub>	72.5	2 <sup>55</sup> / <sub>64</sub>	174	6 <sup>55</sup> / <sub>64</sub>
50EST	247	9 <sup>2</sup> / <sub>3</sub>	105	4 <sup>9</sup> / <sub>64</sub>	239	9 <sup>25</sup> / <sub>64</sub>	50	1 <sup>31</sup> / <sub>32</sub>	64.4	2 <sup>17</sup> / <sub>32</sub>	120.7	2 <sup>3</sup> / <sub>4</sub>	72.5	2 <sup>55</sup> / <sub>64</sub>	186	7 <sup>21</sup> / <sub>64</sub>
55EST	258	10 <sup>1</sup> / <sub>8</sub>	136	5 <sup>3</sup> / <sub>8</sub>	290	11 <sup>7</sup> / <sub>16</sub>	62	2 <sup>7</sup> / <sub>16</sub>	59.5	2 <sup>5</sup> / <sub>16</sub>	160	6 <sup>1</sup> / <sub>4</sub>	80	3 <sup>1</sup> / <sub>8</sub>	209	8 <sup>1</sup> / <sub>4</sub>
65EST	274	10 <sup>3</sup> / <sub>4</sub>	142	5 <sup>9</sup> / <sub>16</sub>	290	11 <sup>7</sup> / <sub>16</sub>	62	2 <sup>7</sup> / <sub>16</sub>	59.5	2 <sup>5</sup> / <sub>16</sub>	160	6 <sup>1</sup> / <sub>4</sub>	80	3 <sup>1</sup> / <sub>8</sub>	234	9 <sup>1</sup> / <sub>4</sub>
70EST	274	10 <sup>13</sup> / <sub>16</sub>	142	5 <sup>5</sup> / <sub>8</sub>	290	11 <sup>7</sup> / <sub>16</sub>	62	2 <sup>7</sup> / <sub>16</sub>	67.5	2 <sup>11</sup> / <sub>16</sub>	160	6 <sup>1</sup> / <sub>4</sub>	80	3 <sup>1</sup> / <sub>8</sub>	282	11 <sup>1</sup> / <sub>8</sub>
70/3EST	319	12 <sup>9</sup> / <sub>16</sub>	186	7 <sup>5</sup> / <sub>16</sub>	290	11 <sup>7</sup> / <sub>16</sub>	62	2 <sup>7</sup> / <sub>16</sub>	67.5	2 <sup>11</sup> / <sub>16</sub>	160	6 <sup>1</sup> / <sub>4</sub>	80	3 <sup>1</sup> / <sub>8</sub>	294	11 <sup>9</sup> / <sub>16</sub>
80EST	320	12 <sup>10</sup> / <sub>16</sub>	174	6 <sup>7</sup> / <sub>8</sub>	290	11 <sup>7</sup> / <sub>16</sub>	62	2 <sup>7</sup> / <sub>16</sub>	67.5	2 <sup>11</sup> / <sub>16</sub>	160	6 <sup>1</sup> / <sub>4</sub>	80	3 <sup>1</sup> / <sub>8</sub>	294	11 <sup>9</sup> / <sub>16</sub>
80/3EST	320	12 <sup>10</sup> / <sub>16</sub>	174	6 <sup>7</sup> / <sub>8</sub>	290	11 <sup>7</sup> / <sub>16</sub>	62	2 <sup>7</sup> / <sub>16</sub>	67.5	2 <sup>11</sup> / <sub>16</sub>	160	6 <sup>1</sup> / <sub>4</sub>	80	3 <sup>1</sup> / <sub>8</sub>	294	11 <sup>9</sup> / <sub>16</sub>
90EST	327	12 <sup>7</sup> / <sub>8</sub>	160	6 <sup>1</sup> / <sub>4</sub>	290	11 <sup>7</sup> / <sub>16</sub>	62	2 <sup>7</sup> / <sub>16</sub>	-	-	-	-	-	-	326	12 <sup>3</sup> / <sub>4</sub>

## Mounting Instructions

40EST	5 X M6 (1/2 IN) C'SK HEAD SCREWS ON 121MM (4 <sup>3</sup> / <sub>4</sub> IN) PCD
45EST	5 X M8 (5/16 IN) C'SK HEAD SCREWS ON 136MM (5 <sup>11</sup> / <sub>32</sub> IN) PCD
50EST	6 X M8 (5/16 IN) C'SK HEAD SCREWS ON 150MM (5 <sup>29</sup> / <sub>32</sub> IN) PCD
55EST	6 X M8 (5/16 IN) C'SK HEAD SCREWS ON 165MM (6 <sup>1</sup> / <sub>2</sub> IN) PCD
65EST	5 X M10 (3/8 IN) C'SK HEAD SCREWS ON 184MM (7 <sup>1</sup> / <sub>4</sub> IN) PCD
70EST	6 X M10 (3/8 IN) C'SK HEAD SCREWS ON 241MM (9 <sup>1</sup> / <sub>2</sub> IN) PCD
70/3EST	6 X M10 (3/8 IN) C'SK HEAD SCREWS ON 241MM (9 <sup>1</sup> / <sub>2</sub> IN) PCD
80EST	6 X M10 (3/8 IN) C'SK HEAD SCREWS ON 241MM (9 <sup>1</sup> / <sub>2</sub> IN) PCD
80/3EST	6 X M10 (3/8 IN) C'SK HEAD SCREWS ON 241MM (9 <sup>1</sup> / <sub>2</sub> IN) PCD
90/3EST	8 X M10 (3/8 IN) C'SK HEAD SCREWS ON 270MM (10 <sup>5</sup> / <sub>8</sub> IN) PCD

NOTE: NOT ALL HOLES ARE SYMMETRICAL ON ALL MODELS

## 6. Winch



### EVO® Race Winches

The new EVO® Race winches combine EVO® architecture with all-new top components to offer a sleek, race look. Significant weight savings are made through the use of an aluminium drum.

- No tools required for servicing
- Cast aluminium feeder arm
- Black anodised drum
- Carbon fibre top inlay feature
- Silver trim band and white decals



Dimensions Diagram EVO® Race Winch

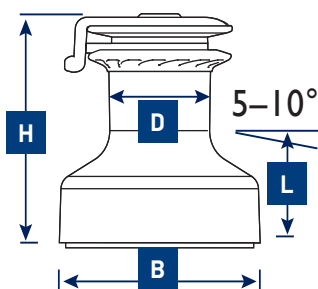

#### EVO® Race Self-Tailing Winch Specifications

PART NO	SIZE	GEAR RATIO		POWER RATIO		WLL		WEIGHT		D DRUM DIA		B BASE DIA		H HEIGHT		L LINE ENTRY		LINE SIZE	
		1ST	2ND	1ST	2ND	KG	LB	KG	LB	MM	IN	MM	IN	MM	IN	MM	IN	MM	IN
49730055	30ST	2:1	4.2:1	13.8:1	29.2:1	685	1510	4	8.8	74	2 <sup>15</sup> / <sub>16</sub>	138	5 <sup>7</sup> / <sub>16</sub>	145.85	5 <sup>3</sup> / <sub>4</sub>	69	2 <sup>11</sup> / <sub>16</sub>	8-12	5 <sup>1</sup> / <sub>16</sub> -1 <sup>1</sup> / <sub>2</sub>
49740055	40ST	1.9:1	5.8:1	13.2:1	40.2:1	795	1753	4.9	10.7	74	2 <sup>15</sup> / <sub>16</sub>	148	5 <sup>13</sup> / <sub>16</sub>	158.5	6 <sup>1</sup> / <sub>4</sub>	79	3 <sup>1</sup> / <sub>8</sub>	8-12	5 <sup>1</sup> / <sub>16</sub> -1 <sup>1</sup> / <sub>2</sub>
49745055	45ST	2.4:1	7.6:1	13.9:1	44.8:1	1200	2646	7.1	15.6	87	3 <sup>7</sup> / <sub>16</sub>	168	6 <sup>5</sup> / <sub>8</sub>	177.7	7	84	3 <sup>5</sup> / <sub>16</sub>	8-14	5 <sup>1</sup> / <sub>16</sub> -9 <sup>1</sup> / <sub>16</sub>
49750055	50ST	2.6:1	9:1	13.9:1	48.6:1	1250	2756	9	19.8	93	3 <sup>9</sup> / <sub>8</sub>	181	7 <sup>1</sup> / <sub>8</sub>	197	7 <sup>3</sup> / <sub>4</sub>	90	3 <sup>1</sup> / <sub>2</sub>	8-14	5 <sup>1</sup> / <sub>16</sub> -9 <sup>1</sup> / <sub>16</sub>
49755055	55ST	2.8:1	11.2:1	13.8:1	54:1	1480	3263	12.2	26.9	105	4 <sup>1</sup> / <sub>8</sub>	205	8 <sup>1</sup> / <sub>16</sub>	233	9 <sup>1</sup> / <sub>32</sub>	115	4 <sup>1</sup> / <sub>2</sub>	8-16	5 <sup>1</sup> / <sub>16</sub> -5 <sup>5</sup> / <sub>8</sub>



## Lewmar EVO® Race+™ Winch

Lewmar's EVO® Race+™ winches use a lightweight cast aluminium base stem and machined aluminium upper stem, together with other advanced material choices, to offer significant weight savings over standard EVO® winches.

- Lightweight centre stem
- Lightened main spindle
- Cast aluminium feeder arm
- Composite bearing technology
- "No tools" servicing
- Carbon fibre inlay
- Silver trim stripe
- White pad-printed decals
- Black anodised drum



Dimensions Diagram EVO® Race+™ Winch

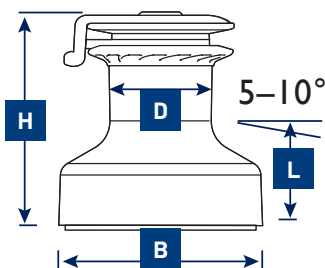

EVO® Race+™ Self-Tailing Winch Specifications

PART NO	SIZE	GEAR RATIO		POWER RATIO		WLL		WEIGHT		D DRUM DIA		B BASE DIA		H HEIGHT		L LINE ENTRY		LINE SIZE	
		1ST	2ND	1ST	2ND	KG	LB	KG	LB	MM	IN	MM	IN	MM	IN	MM	IN	MM	IN
49940055	40ST	1.9:1	5.8:1	13.2:1	40.2:1	795	1753	3.6	7.9	74	2 <sup>15</sup> / <sub>16</sub>	148	5 <sup>13</sup> / <sub>16</sub>	158.5	6 <sup>1</sup> / <sub>4</sub>	79	3 <sup>3</sup> / <sub>8</sub>	8-12	5 <sup>5</sup> / <sub>16</sub> -1 <sup>1</sup> / <sub>2</sub>
49945055	45ST	2.4:1	7.6:1	13.9:1	44.8:1	1200	2646	4.8	10.5	87	3 <sup>7</sup> / <sub>16</sub>	168	6 <sup>5</sup> / <sub>8</sub>	177.7	7	84	3 <sup>9</sup> / <sub>16</sub>	8-14	5 <sup>9</sup> / <sub>16</sub> -9 <sup>1</sup> / <sub>16</sub>
49950055	50ST	2.6:1	9:1	13.9:1	48.6:1	1250	2756	6.3	13.9	93	3 <sup>9</sup> / <sub>8</sub>	181	7 <sup>1</sup> / <sub>8</sub>	197	7 <sup>3</sup> / <sub>4</sub>	90	3 <sup>1</sup> / <sub>2</sub>	8-14	5 <sup>9</sup> / <sub>16</sub> -9 <sup>1</sup> / <sub>16</sub>
49955055	55ST	2.8:1	11.2:1	13.8:1	54:1	1480	3263	8.3	18.3	105	4 1/8	205	8 1/16	250	9 13/16	115	4 1/2	8-16	5 <sup>9</sup> / <sub>16</sub> -5 <sup>5</sup> / <sub>8</sub>

## 6. Winch



### EVO® Speed Ring Winch

EVO® Speed Ring racing winches offer all the features of the EVO® Range with the additional benefit of two drum diameters. The larger drum offers increased line speeds associated with fast asymmetric spinnaker gybes or hoists while the standard size drum allows fine tuning, removing the need for additional winches.

- Easy servicing – no tools required
- Available in black or grey alloy finish
- Features two drum diameters for greater control



Dimensions Diagram EVO® Speed Ring Winch

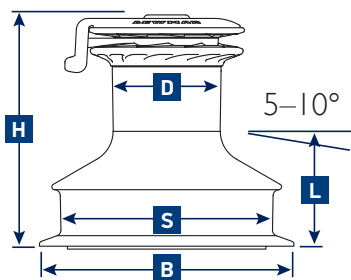

### EVO® Speed Ring Winch Specifications

PART NO	SIZE	FINISH	GEAR RATIO		POWER RATIO		SPEED RING POWER RATIO		WLL		WEIGHT		D DRUM DIA		S SPEED RING DIA		B BASE DIA		H HEIGHT		L LINE ENTRY		LINE SIZE	
			1ST	2ND	1ST	2ND	1ST	2ND	KG	LB	KG	LB	MM	IN	MM	IN	MM	IN	MM	IN	MM	IN	MM	IN
49540085	40	BLACK	1.9:1	5.8:1	13.2:1	40.2:1	6.6:1	20.3:1	795	1753	4.9	10.7	74	2 <sup>5</sup> / <sub>16</sub>	145.5	5 <sup>3</sup> / <sub>4</sub>	148	5 <sup>13</sup> / <sub>16</sub>	158.5	6 <sup>1</sup> / <sub>4</sub>	79	3 <sup>1</sup> / <sub>8</sub>	8-12	5 <sup>1</sup> / <sub>16</sub> -1/2
49540087	40	GREY	1.9:1	5.8:1	13.2:1	40.2:1	6.6:1	20.3:1	795	1753	4.9	10.7	74	2 <sup>5</sup> / <sub>16</sub>	145.5	5 <sup>3</sup> / <sub>4</sub>	148	5 <sup>13</sup> / <sub>16</sub>	158.5	6 <sup>1</sup> / <sub>4</sub>	79	3 <sup>1</sup> / <sub>8</sub>	8-12	5 <sup>1</sup> / <sub>16</sub> -1/2
49545085	45	BLACK	2.36:1	8.0:1	13.86:1	46.8:1	7:1	22.6:1	1200	2643	7.6	16.7	86.8	3 <sup>7</sup> / <sub>16</sub>	170.5	6 <sup>3</sup> / <sub>4</sub>	205	8	177.5	7	84.5	3 <sup>9</sup> / <sub>16</sub>	8-12	5 <sup>1</sup> / <sub>16</sub> -1/2
49545087	45	GREY	2.36:1	8.0:1	13.86:1	46.8:1	7:1	22.6:1	1200	2643	7.6	16.7	86.8	3 <sup>7</sup> / <sub>16</sub>	170.5	6 <sup>3</sup> / <sub>4</sub>	205	8	177.5	7	84.5	3 <sup>9</sup> / <sub>16</sub>	8-12	5 <sup>1</sup> / <sub>16</sub> -1/2





## EVO® Sport Winch

The EVO® Sport complements the EVO® Winch Range. Best suited for sport boats requiring constant trimming, and where weight consideration is a premium. The EVO® Sport is also suitable as a mast mounted winch.

- Architecture based on self tailing EVO® Winch
- Tool-free servicing
- Size 30 and 40 can be converted into an EVO® Self tailing winch retrospectively
- Size 40 convertible to electric
- Choice of finishes: Black alloy or Chrome bronze
- Available in size 6 to size 40



### Dimensions Diagram EVO® Sport Winch

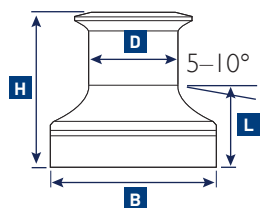

### EVO® Sport Winch Specifications

PART NO	MODEL	FINISH	GEAR RATIO		POWER RATIO		WLL		WEIGHT		D DRUM DIA		B BASE DIA		H HEIGHT		L LINE ENTRY		MOUNTING INSTRUCTIONS
			1ST	2ND	1ST	2ND	KG	LB	KG	LB	MM	IN	MM	IN	MM	IN	MM	IN	
49006075	6	ALLOY BLACK	1:1	-	6.8:1	-	341	752	0.5	1.1	59	2 <sup>5</sup> / <sub>16</sub>	94	3 <sup>11</sup> / <sub>16</sub>	83	3 <sup>1</sup> / <sub>4</sub>	35.5	1 <sup>3</sup> / <sub>8</sub>	4 X M6 (1/4 IN) C'SK HEAD SCREWS ON 66MM (2 <sup>19</sup> / <sub>32</sub> IN) PCD
19006100	6	CHROME	1:1	-	6.8:1	-	341	752	1.1	2.4	59	2 <sup>5</sup> / <sub>16</sub>	94	3 <sup>11</sup> / <sub>16</sub>	83	3 <sup>1</sup> / <sub>4</sub>	35.5	1 <sup>3</sup> / <sub>8</sub>	
49507075	7	ALLOY BLACK	1:1	-	7.9:1	-	341	752	0.8	1.8	65	2 <sup>9</sup> / <sub>16</sub>	108	4 <sup>1</sup> / <sub>4</sub>	102	4	40	1 <sup>3</sup> / <sub>4</sub>	5 X M6 (1/4 IN) C'SK HEAD SCREWS ON 80MM (3 <sup>5</sup> / <sub>32</sub> IN) PCD
49507076	7	CHROME	1:1	-	7.9:1	-	341	752	1.7	3.7	65	2 <sup>9</sup> / <sub>16</sub>	108	4 <sup>1</sup> / <sub>4</sub>	102	4	40	1 <sup>3</sup> / <sub>4</sub>	
49508075	8	ALLOY BLACK	1:1	-	7.9:1	-	455	1003	1.4	3.1	65	2 <sup>9</sup> / <sub>16</sub>	108	4 <sup>1</sup> / <sub>4</sub>	103	4 <sup>1</sup> / <sub>16</sub>	40	1 <sup>9</sup> / <sub>16</sub>	5 X M6 (1/4 IN) C'SK HEAD SCREWS ON 80MM (3 <sup>5</sup> / <sub>32</sub> IN) PCD
49508076	8	CHROME	1:1	-	7.9:1	-	455	1003	2.3	5.1	65	2 <sup>9</sup> / <sub>16</sub>	108	4 <sup>1</sup> / <sub>4</sub>	103	4 <sup>1</sup> / <sub>16</sub>	40	1 <sup>9</sup> / <sub>16</sub>	
49516075	15	ALLOY BLACK	1:1	2:1	7.9:1	16:1	570	1257	2.1	4.6	67	2 <sup>5</sup> / <sub>8</sub>	120	4 <sup>3</sup> / <sub>4</sub>	112	4 <sup>7</sup> / <sub>16</sub>	55	2 <sup>3</sup> / <sub>16</sub>	5 X M6 (1/4 IN) C'SK HEAD SCREWS ON 94MM (3 <sup>11</sup> / <sub>16</sub> IN) PCD
49516076	15	CHROME	1:1	2:1	7.9:1	16:1	570	1257	3.2	7.0	67	2 <sup>5</sup> / <sub>8</sub>	120	4 <sup>3</sup> / <sub>4</sub>	112	4 <sup>7</sup> / <sub>16</sub>	55	2 <sup>3</sup> / <sub>16</sub>	
49530075	30	ALLOY BLACK	2:1	4.2:1	13.8:1	29.2:1	685	1510	3.9	8.6	74	2 <sup>15</sup> / <sub>16</sub>	138	5 <sup>1</sup> / <sub>16</sub>	145.85	5 <sup>3</sup> / <sub>4</sub>	69	2 <sup>11</sup> / <sub>16</sub>	5 X M6 (1/2 IN) C'SK HEAD SCREWS ON 113MM (4 <sup>15</sup> / <sub>32</sub> IN) PCD
49530076	30	CHROME	2:1	4.2:1	13.8:1	29.2:1	685	1510	5.8	12.8	74	2 <sup>15</sup> / <sub>16</sub>	138	5 <sup>1</sup> / <sub>16</sub>	145.85	5 <sup>3</sup> / <sub>4</sub>	69	2 <sup>11</sup> / <sub>16</sub>	
49540075	40	ALLOY BLACK	1.9:1	5.8:1	13.2:1	40.2:1	795	1753	5.5	12.1	74	2 <sup>15</sup> / <sub>16</sub>	148	5 <sup>13</sup> / <sub>16</sub>	158.5	6 <sup>1</sup> / <sub>4</sub>	79	3 <sup>1</sup> / <sub>8</sub>	5 X M6 (1/2 IN) C'SK HEAD SCREWS ON 121MM (4 <sup>3</sup> / <sub>4</sub> IN) PCD
49540076	40	CHROME	1.9:1	5.8:1	13.2:1	40.2:1	795	1753	7	15.4	74	2 <sup>15</sup> / <sub>16</sub>	148	5 <sup>13</sup> / <sub>16</sub>	158.5	6 <sup>1</sup> / <sub>4</sub>	79	3 <sup>1</sup> / <sub>8</sub>	

## 6. Winch



### Ocean Self-Tailing Winches

Lewmar's Ocean winch range is the most popular winch ever made. Its styling still attracts boat builders looking for a classic look, or boat owners looking to upgrade or replace their existing winches.

- Easy Servicing – no tools required
- Bronze finish also available - contact your retailer
- Convertable to electric from size 40 upwards
- Available in Size 16 to Size 65
- Solid construction respected by boat builders and sailors for generations



#### Ocean Self-Tailing Winch Specifications

PART NO	MODEL	FINISH	GEAR RATIO			POWER RATIO			WLL		WEIGHT		DRUM DIA		BASE DIA		HEIGHT		ENTRY LINE		LINE SIZE	
			1ST	2ND	3RD	1ST	2ND	3RD	KG	LB	KGW	LB	MM	IN	MM	IN	MM	IN	MM	IN	MM	IN
49016000	16ST	ALLOY GREY	2:1	-		15.8:1	-		570	1257	2.9	6.4	65.7	2 <sup>9</sup> / <sub>16</sub>	121	4 <sup>3</sup> / <sub>4</sub>	145.5	5 <sup>3</sup> / <sub>4</sub>	58	2 <sup>5</sup> / <sub>16</sub>	8-12	5/16-1/2
49016001	16ST	CHROME BRONZE	2:1	-		15.8:1	-		570	1257	3.9	8.6	65.7	2 <sup>9</sup> / <sub>16</sub>	121	4 <sup>3</sup> / <sub>4</sub>	145.5	5 <sup>3</sup> / <sub>4</sub>	58	2 <sup>5</sup> / <sub>16</sub>	8-12	5/16-1/2
49030000	30ST	ALLOY GREY	2:1	4.2:1		13.8:1	29.2:1		685	1510	4.2	9.2	74	2 <sup>15</sup> / <sub>16</sub>	138	5 <sup>7</sup> / <sub>16</sub>	160.5	6 <sup>5</sup> / <sub>16</sub>	69	2 <sup>1</sup> / <sub>16</sub>	8-12	5/16-1/2
49030001	30ST	CHROME BRONZE	2:1	4.2:1		13.8:1	29.2:1		685	1510	5.6	12.3	74	2 <sup>15</sup> / <sub>16</sub>	138	5 <sup>7</sup> / <sub>16</sub>	160.5	6 <sup>5</sup> / <sub>16</sub>	69	2 <sup>1</sup> / <sub>16</sub>	8-12	5/16-1/2
49040055	40ST	ALLOY GREY	1.9:1	5.8:1		13.2:1	40.2:1		795	1753	4.9	10.7	74	2 <sup>15</sup> / <sub>16</sub>	148	5 <sup>13</sup> / <sub>16</sub>	173	6 <sup>13</sup> / <sub>16</sub>	79	3 <sup>1</sup> / <sub>8</sub>	8-12	5/16-1/2
49040056	40ST	CHROME BRONZE	1.9:1	5.8:1		13.2:1	40.2:1		795	1753	6.5	14.3	74	2 <sup>15</sup> / <sub>16</sub>	148	5 <sup>13</sup> / <sub>16</sub>	173	6 <sup>13</sup> / <sub>16</sub>	79	3 <sup>1</sup> / <sub>8</sub>	8-12	5/16-1/2
49046055	46ST	ALLOY GREY	2.4:1	7.6:1		13.9:1	44.8:1		1200	2646	7.2	15.8	87	3 <sup>7</sup> / <sub>16</sub>	168	6 <sup>5</sup> / <sub>8</sub>	192	7 <sup>9</sup> / <sub>16</sub>	84	3 <sup>5</sup> / <sub>16</sub>	8-14	5/16-9/16
49046056	46ST	CHROME BRONZE	2.4:1	7.6:1		13.9:1	44.8:1		1200	2646	9.7	21.3	87	3 <sup>7</sup> / <sub>16</sub>	168	6 <sup>5</sup> / <sub>8</sub>	192	7 <sup>9</sup> / <sub>16</sub>	84	3 <sup>5</sup> / <sub>16</sub>	8-14	5/16-9/16
49048055	48ST	ALLOY GREY	2.6:1	9:1		13.9:1	48.6:1		1250	2756	8.8	19.4	93	3 <sup>7</sup> / <sub>8</sub>	181	7 <sup>1</sup> / <sub>8</sub>	208	8 <sup>3</sup> / <sub>16</sub>	86	3 <sup>3</sup> / <sub>8</sub>	8-14	5/16-9/16
49048056	48ST	CHROME BRONZE	2.6:1	9:1		13.9:1	48.6:1		1250	2756	12.1	26.7	93	3 <sup>7</sup> / <sub>8</sub>	181	7 <sup>1</sup> / <sub>8</sub>	208	8 <sup>3</sup> / <sub>16</sub>	86	3 <sup>3</sup> / <sub>8</sub>	8-14	5/16-9/16
49050000	50ST	ALLOY GREY	2.8:1	10.5:1		13.8:1	50.6:1		1250	2756	11.3	24.9	105	4 <sup>1</sup> / <sub>8</sub>	200	7 <sup>7</sup> / <sub>8</sub>	238	9 <sup>3</sup> / <sub>8</sub>	106	4 <sup>3</sup> / <sub>16</sub>	8-16	5/16-5/8
49050001	50ST	CHROME BRONZE	2.8:1	10.5:1		13.8:1	50.6:1		1250	2756	16.3	35.9	105	4 <sup>1</sup> / <sub>8</sub>	200	7 <sup>7</sup> / <sub>8</sub>	238	9 <sup>3</sup> / <sub>8</sub>	106	4 <sup>3</sup> / <sub>16</sub>	8-16	5/16-5/8
49054000	54ST	ALLOY GREY	2.8:1	11.2:1		13.8:1	54:1		1480	3263	12.0	26.4	105	4 <sup>1</sup> / <sub>8</sub>	205	8 <sup>1</sup> / <sub>16</sub>	250	9 <sup>7</sup> / <sub>8</sub>	115	4 <sup>1</sup> / <sub>2</sub>	8-16	5/16-5/8
49054001	54ST	CHROME BRONZE	2.8:1	11.2:1		13.8:1	54:1		1480	3263	17.0	37.5	105	4 <sup>1</sup> / <sub>8</sub>	205	8 <sup>1</sup> / <sub>16</sub>	250	9 <sup>7</sup> / <sub>8</sub>	115	4 <sup>1</sup> / <sub>2</sub>	8-16	5/16-5/8
49058000	58ST	ALLOY GREY	3.1:1	13.5:1		13.5:1	58.1:1		1600	3524	14.3	31.5	118	4 <sup>5</sup> / <sub>8</sub>	228	9	266	10 <sup>1</sup> / <sub>2</sub>	118.5	4 <sup>1</sup> / <sub>16</sub>	8-18	5/16-11/16
49058001	58ST	CHROME BRONZE	3.1:1	13.5:1		13.5:1	58.1:1		1600	3524	20.8	45.8	118	4 <sup>5</sup> / <sub>8</sub>	228	9	266	10 <sup>1</sup> / <sub>2</sub>	118.5	4 <sup>1</sup> / <sub>16</sub>	8-18	5/16-11/16
49065000	65ST	ALLOY GREY	3.1:1	15.3:1		13.4:1	66:1		1700	3748	16.6	36.5	118	4 <sup>5</sup> / <sub>8</sub>	231	9 <sup>1</sup> / <sub>8</sub>	271	10 <sup>1</sup> / <sub>16</sub>	121.5	4 <sup>13</sup> / <sub>16</sub>	8-18	5/16-11/16
49065001	65ST	CHROME BRONZE	3.1:1	15.3:1		13.4:1	66:1		1700	3748	23.8	52.4	118	4 <sup>5</sup> / <sub>8</sub>	231	9 <sup>1</sup> / <sub>8</sub>	271	10 <sup>1</sup> / <sub>16</sub>	121.5	4 <sup>13</sup> / <sub>16</sub>	8-18	5/16-11/16
49066000	68ST	ALLOY GREY	5.8:1	18.8:1		20.9:1	67.6:1		3000	6614	20	44	141	5 <sup>9</sup> / <sub>16</sub>	282	11 <sup>1</sup> / <sub>8</sub>	302	11 <sup>7</sup> / <sub>8</sub>	142	5 <sup>5</sup> / <sub>8</sub>	10-20	3/8-3/4
49066001	68ST	CHROME BRONZE	5.8:1	18.8:1		20.9:1	67.6:1		3000	6614	26.8	59	141	5 <sup>9</sup> / <sub>16</sub>	282	11 <sup>1</sup> / <sub>8</sub>	302	11 <sup>7</sup> / <sub>8</sub>	142	5 <sup>5</sup> / <sub>8</sub>	10-20	3/8-3/4
49066005	68ST 3	ALLOY GREY	2.8:1	8:1	19.3:1	9.9:1	29:1	69.3:1	3000	6614	22.0	48.4	141	5 <sup>9</sup> / <sub>16</sub>	294	11 <sup>5</sup> / <sub>8</sub>	348	13 <sup>3</sup> / <sub>4</sub>	186.4	7 <sup>3</sup> / <sub>8</sub>	10-20	3/8-3/4
49066006	68ST 3	CHROME BRONZE	2.8:1	8:1	19.3:1	9.9:1	29:1	69.3:1	3000	6614	28.8	63.4	141	5 <sup>9</sup> / <sub>16</sub>	294	11 <sup>5</sup> / <sub>8</sub>	348	13 <sup>3</sup> / <sub>4</sub>	186.4	7 <sup>3</sup> / <sub>8</sub>	10-20	3/8-3/4
49077000	77ST	ALLOY GREY	8:1	27:1		23:1	77:1		3500	7716	23.8	52.4	178	7	294	11 <sup>5</sup> / <sub>8</sub>	348	13 <sup>3</sup> / <sub>4</sub>	174	6 <sup>7</sup> / <sub>8</sub>	12-22	1/2-7/8
49077001	77ST	CHROME BRONZE	8:1	27:1		23:1	77:1		3500	7716	30.6	67.3	178	7	294	11 <sup>5</sup> / <sub>8</sub>	348	13 <sup>3</sup> / <sub>4</sub>	174	6 <sup>7</sup> / <sub>8</sub>	12-22	1/2-7/8
49077005	77ST 3	ALLOY GREY	2.8:1	8:1	27:1	7.9:1	23:1	77:1	3500	7716	25.8	56.8	178	7	294	11 <sup>5</sup> / <sub>8</sub>	348	13 <sup>3</sup> / <sub>4</sub>	174	6 <sup>7</sup> / <sub>8</sub>	12-22	1/2-7/8
49077006	77ST 3	CHROME BRONZE	2.8:1	8:1	27:1	7.9:1	23:1	77:1	3500	7716	32.8	72.2	178	7	294	11 <sup>5</sup> / <sub>8</sub>	348	13 <sup>3</sup> / <sub>4</sub>	174	6 <sup>7</sup> / <sub>8</sub>	12-22	1/2-7/8



### Mounting Instructions

OCEAN 16ST	5 X M6 (1/4 IN) C'SK HEAD SCREWS ON 94MM (3 11/16 IN) PCD
OCEAN 30ST	5 X M6 (1/4 IN) C'SK HEAD SCREWS ON 113MM (4 5/32 IN) PCD
OCEAN 40ST	5 X M6 (1/4 IN) C'SK HEAD SCREWS ON 121MM (4 7/8 IN) PCD
OCEAN 46ST	5 X M8 (5/16 IN) C'SK HEAD SCREWS ON 136MM (5 11/32 IN) PCD

OCEAN 48ST	5 X M8 (5/16 IN) C'SK HEAD SCREWS ON 150MM (5 29/32 IN) PCD
OCEAN 50-54ST	6 X M8 (5/16 IN) C'SK HEAD SCREWS ON 165MM (6 1/2 IN) PCD
OCEAN 58-65ST	5 X M10 (3/8 IN) C'SK HEAD SCREWS ON 184MM (7 1/4 IN) PCD



### Custom Options

Custom engraving option available on the upper crown for special one-off projects.

Please contact [custom@lewmar.com](mailto:custom@lewmar.com) for more details

### Ocean Winch Electric Conversion Kit

Upgrade your manual winch to an electric model with the Ocean upgrade kit. The kit contains all you need to convert your existing manual winch to an electric powered version.

PART NUMBER	DESCRIPTION
48040300	40ST 12V 'E' CONVERSION KIT
48046300	46ST 12V 'E' CONVERSION KIT
48048300	48ST 12V 'E' CONVERSION KIT
48050300	50ST 12V 'ELS' CONVERSION KIT
48054300	54ST 12V 'ELS' CONVERSION KIT
48058300	58ST 12V 'ELS' CONVERSION KIT
48065300	65ST 12V 'ELS' CONVERSION KIT

### Kit includes

<p><b>1</b></p>  <p>Power Drive</p>	<p><b>2</b></p>  <p>Motor Gearbox</p>	<p><b>3</b></p>  <p>Contactor</p>	<p><b>3</b></p>  <p>Circuit Breaker</p>	<p><b>4</b></p>  <p>Switch</p>
--	--	--	--	---

## 6. Winch



### High Performance Winch Range

#### 40-65 EVO® High Performance Electric Range

With sailboat market trends focussed on easier sail handling and operation, there has been a significant increase in the quantity of electric winches being used on board.

Lewmar have developed a new, high performance solution, combining our EVO® deck unit with an optimised and upgraded motor gearbox package. In its high performance configuration, the EVO® can achieve an increase of up to 35% in line speed with up to 20% higher max pull.

The winch range is available in a variety of finishes including aluminium and chrome designs, offering tool-free servicing.

The high performance power unit is fully compatible with the existing EVO® electric range and is available as an optional upgrade from either manual winch or the conversion of an existing electric EVO®.



EVO 45 Electric Performance

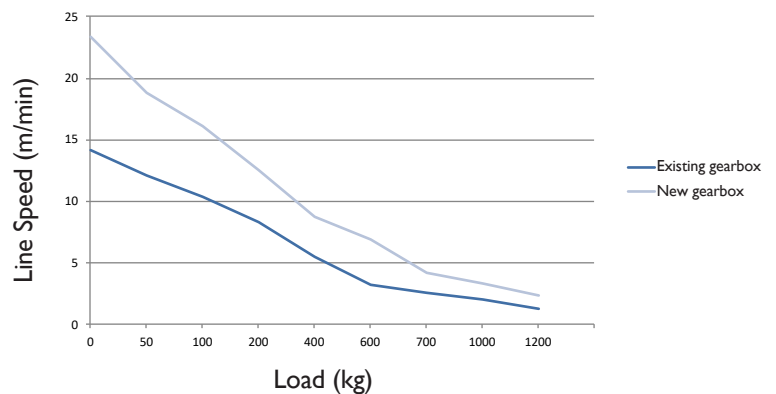



### 65 EVO<sup>®</sup> High Performance 2-Speed Electric Winch

Lewmar have further expanded our winch capabilities by developing a revolutionary 2-speed electric winch. Using innovative gearing design, Lewmar have built upon the strong EVO<sup>®</sup> platform to create a performance product with incredible versatility. In both electric and manual modes, the 65 EVO<sup>®</sup> 2-speed is designed for smoother trimming under high loads at faster line speeds.

- Increased line speed (43m/min)
- Increased pulling loads (2200kg WLL)
- Optional twin or single button fast sheet and slow trimming controls



EVO 65 Electric Performance

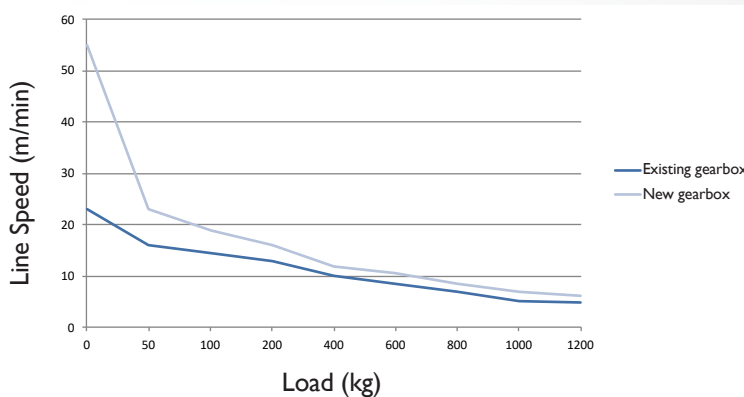

## 6. Winch



### Hydraulic Winches

Lewmar's hydraulic powered winches combine the benefits of electric winches with system integration. The installation of a cost-effective, multi-function hydraulic system on boats over 15m (50ft) enables short-handed sailing through push-button control of winches and other integrated deck functions.

- Suitable for craft over 15m (50ft)
- Minimal internal space required for compact motor
- Low weight
- Manual override facility
- Quiet operation
- Push button control
- Choice of styling - Ocean traditional style available as well as the modern lines of the EVO® range

#### Push button control

Combining Lewmar's push button operation and Lewmar's Wavespring self-tailer produces simple hands free sailing whatever sheeting operation is to be carried out.

#### Manual override

Manual override can be effected simply and quickly through winch handle insertion.

#### Minimal space and weight

The hydraulic motor is extremely compact ensuring minimal internal space used, while being less obtrusive below deck. All achieved without compromising power.

#### Quiet operation

By using hydraulic power the winch operation is performed in near silence, adding to your sailing experience.



Hydraulic EVO®  
winch

## Hydraulic Winch Specifications

OCEAN WINCH PART NO	EVO WINCH PART NO	MODEL	FINISH	APPROXIMATE WEIGHT		LINE SIZE		MOUNTING INSTRUCTIONS
				KG	LB	MM	IN	
49046155	49545100	46HST OCEAN / 45HST EVO	ALLOY GREY	16	34	8-14	5/16-9/16	5 X M8 (5/16 IN) C'SK HEAD SCREWS ON 136MM (5 1/32 IN) PCD
49046156	495451**	46HST OCEAN / 45HST EVO	CHROME	18	41	8-14	5/16-9/16	
	495451**	45HST EVO	ALLOY BLACK	16	34	8-14	5/16-9/16	
49046158		46HST OCEAN	STAINLESS STEEL	18	40	8-14	5/16-9/16	
49046159		46HST OCEAN	ALL CHROME	19	42	8-14	5/16-9/16	
490481**	49550100	48HST OCEAN / 50HST EVO	ALLOY GREY	17	38	8-14	5/16-9/16	6 X M8 (5/16 IN) C'SK HEAD SCREWS ON 165MM (6 1/2 IN) PCD
49048156	49550101	48HST OCEAN / 50HST EVO	CHROME	21	46	8-14	5/16-9/16	
	49550110	50HST EVO	ALLOY BLACK	17	38	8-14	5/16-9/16	
49048158		48HST OCEAN	STAINLESS STEEL	20	45	8-14	5/16-9/16	
49048159		48HST OCEAN	ALL CHROME	22	48	8-14	5/16-9/16	
490501**		50HST OCEAN	ALLOY GREY	20	44	8-16	5/16-5/8	6 X M8 (5/16 IN) C'SK HEAD SCREWS ON 165MM (6 1/2 IN) PCD
49050101		50HST OCEAN	CHROME	25	54	8-16	5/16-5/8	
490501**		50HST OCEAN	STAINLESS STEEL	25	55	8-16	5/16-5/8	
49050103		50HST OCEAN	ALL CHROME	25	56	8-16	5/16-5/8	
49054100	49555100	54HST OCEAN / 55HST EVO	ALLOY GREY	21	45	8-16	5/16-5/8	6 X M8 (5/16 IN) C'SK HEAD SCREWS ON 165MM (6 1/2 IN) PCD
49054101	49555101	54HST OCEAN / 55HST EVO	CHROME	26	58	8-16	5/16-5/8	
	495551**	55HST EVO	ALLOY BLACK	21	45	8-16	5/16-5/8	
490541**		54HST OCEAN	STAINLESS STEEL	31	67	8-16	5/16-5/8	
49054103		54HST OCEAN	ALL CHROME	27	60	8-16	5/16-5/8	
49058100		58HST OCEAN	ALLOY GREY	23	50	8-18	5/16-11/16	5 X M10 (3/8 IN) C'SK HEAD SCREWS ON 184MM (7 1/4 IN) PCD
49058101		58HST OCEAN	CHROME	30	67	8-18	5/16-11/16	
49058104		58HST OCEAN	STAINLESS STEEL	29	63	8-18	5/16-11/16	
49058103		58HST OCEAN	ALL CHROME	31	73	8-18	5/16-11/16	
49065100	495651**	65HST OCEAN / EVO	ALLOY GREY	25	55	8-18	5/16-11/16	5 X M10 (3/8 IN) C'SK HEAD SCREWS ON 184MM (7 1/4 IN) PCD
49065101	49565101	65HST OCEAN / EVO	CHROME	32	71	8-18	5/16-11/16	
	495651**	65HST EVO	ALLOY BLACK	25	55	8-18	5/16-11/16	
49065104		65HST OCEAN	STAINLESS STEEL	32	70	8-18	5/16-11/16	
49065103		65HST OCEAN	ALL CHROME	31	73	8-18	5/16-11/16	
49068100	495701**	68HST OCEAN / 70HST EVO	ALLOY GREY	29	63	10-20	3/8-3/4	6 X M10 (3/8 IN) C'SK HEAD SCREWS ON 241MM (9 1/2 IN) PCD
49068101	495701**	68HST OCEAN / 70HST EVO	CHROME	35	78	10-20	3/8-3/4	
	495701**	70HST EVO	ALLOY BLACK	29	63	10-20	3/8-3/4	
49068104		68HST OCEAN	STAINLESS STEEL	34	75	10-20	3/8-3/4	
49068103		68HST OCEAN	ALL CHROME	36	80	10-20	3/8-3/4	
49068105	495701**	68/3HST OCEAN / 70/3HST EVO	ALLOY GREY	40	88	10-20	3/8-3/4	6 X M10 (3/8 IN) C'SK HEAD SCREWS ON 241MM (9 1/2 IN) PCD
49068106	495701**	68/3HST OCEAN / 70/3HST EVO	CHROME	42	93	10-20	3/8-3/4	
	495701**	70/3HST EVO	ALLOY BLACK	40	88	10-20	3/8-3/4	
49068109		68/3HST OCEAN	STAINLESS STEEL	40	88	10-20	3/8-3/4	
49068108		68/3HST OCEAN	ALL CHROME	42	93	10-20	3/8-3/4	
49077100	495801**	77HST OCEAN / 80HST EVO	ALLOY GREY	36	79	12-22	1/2-7/8	6 X M10 (3/8 IN) C'SK HEAD SCREWS ON 241MM (9 1/2 IN) PCD
49077101	49580101	77HST OCEAN / 80HST EVO	CHROME	49	107	12-22	1/2-7/8	
	495801**	80HST EVO	ALLOY BLACK	36	79	12-22	1/2-7/8	
49077104		77HST OCEAN	STAINLESS STEEL	41	89	12-22	1/2-7/8	
49077103		77HST OCEAN	ALL CHROME	49	107	12-22	1/2-7/8	
49077105	49580102	77/3HST OCEAN / 80/3HST EVO	ALLOY GREY	42	92	12-22	1/2-7/8	6 X M10 (3/8 IN) C'SK HEAD SCREWS ON 241MM (9 1/2 IN) PCD
49077106	495801**	77/3HST OCEAN / 80/3HST EVO	CHROME	50	110	12-22	1/2-7/8	
	495801**	80/3HST EVO	ALLOY BLACK	42	92	12-22	1/2-7/8	
49077109		77/3HST OCEAN	STAINLESS STEEL	42	92	12-22	1/2-7/8	
49077108		77/3HST OCEAN	ALL CHROME	50	110	12-22	1/2-7/8	

## 6. Winch



### REVO™ Backwinding Winch

Lewmar introduces a complete range of electrically-operated, backwinding winches. With the touch of a button, sailors are able to trim sails both in and out. Push one button and the winch sheets in quickly to the working load limit.

A well-specified motor removes the added complication of switching between slow and fast forward gears. Simply push another button to allow the winch to pay out line. The insertion of a winch handle automatically changes to a familiar two-speed manual operation.

- Available in five sizes (40, 45, 50, 55, 65)
- No modification to the standard bolting pattern and deck cut-outs
- Direct size for size upgrade from a standard electric EVO® winch to a REVO™ winch
- Uses proven winch internals to retain all the benefits of the EVO® Winch
- Simple two button operation, one to pull sheet in and another to pay out
- Operates as a normal two speed manual winch when a winch handle is inserted

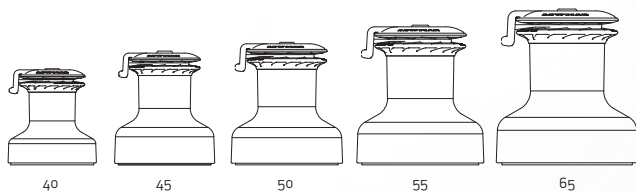





When back-winding, the REVO™ relies on load to strip the rope off the drum, thus avoiding tangles and ensuring rope is only released in the right circumstance.

In order to maximise the performance of the REVO™ winch, applications with minimal mechanical advantage are best, such as genoa/gennaker sheets. Purchase mainsheet systems may present too little load for the backwind feature to work.

In addition, small diameter, hi-tech lines are recommended.

Dimensions Diagram REVO™ Winch

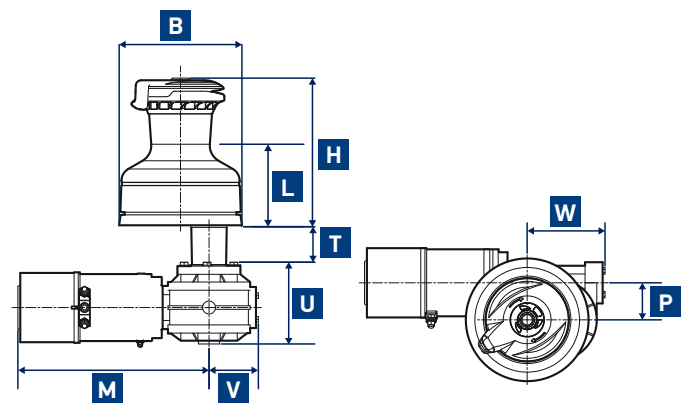

SIZE	M		P		T		U		V		W	
	MM	IN	MM	IN	MM	IN	MM	IN	MM	IN	MM	IN
40	306	12 1/16	50	1 31/32	35	1 3/8	127	5	73	2 7/8	111	4 3/8
45	306	12 1/16	50	1 31/32	65	2 9/16	127	5	73	2 7/8	115	4 17/32
50	306	12 1/16	50	1 31/32	65	2 9/16	127	5	73	2 7/8	117	4 5/8
55	325	12 13/16	63	2 15/32	61	2 13/32	139	5 15/32	84	3 5/16	133	5 1/4
65	325	12 13/16	63	2 15/32	61	2 13/32	139	5 15/32	84	3 5/16	137	5 13/32

### REVO™ Winch Specifications

SIZE	ALLOY BLACK	ALLOY GREY	CHROME	WLL		WEIGHT ALLOY		WEIGHT CHROME		MTR/GBOX	MOTOR WATTS	B BASE DIA		H HEIGHT		L LINE ENTRY	
				KG	LB	KG	LB	KG	LB			MM	IN	MM	IN	MM	IN
40	48340210	48340200	48340201	795	1749	18.8	41.4	20.5	45.1	48300014	700	154	6 1/16	179	6 15/16	98	3 7/8
45	48345210	48345200	48345201	1200	2640	23.1	50.8	25.6	56.3	48300014	700	174	6 27/32	193	7 19/32	103	4 1/16
50	48350210	48350200	48350201	1250	2750	25.7	56.5	29.1	64.0	48300014	700	186	7 11/32	215	8 15/32	109	4 9/32
55	48355210	48355200	48355201	1480	3256	30	66.0	35.8	78.8	48300016	1600	209	8 1/4	253	9 31/32	140	5 1/2
65	48365210	48365200	48365201	1700	3740	34.6	76.1	41.8	92.0	48300016	1600	234	9 7/32	268	10 9/16	144	5 11/16

## 6. Winch



### 3 Contactors & Control Boxes

#### E-series

The E-series contactor is equipped with a thermal trip to monitor the motor temperature, which ensures a cut out if the heat builds up to an unacceptable level.

Available on the EVO® electric winch range 40, 45 & 50.

#### Electric load sensing – ELS

Pioneered by Lewmar, ELS (Electric Load Sensing) electric winches are controlled by an Overload Protection Control Box, which allows the winch to be operated up to a set current relative to the working load limit of the specific winch. Once this current is exceeded, the winch automatically cuts out. Once the current drops to below the working load limit, the winch can be restarted. The ELS features the additional safety function of a motor thermal trip, which ensures that the motor cuts out in the event of excessive heat build up. ELS is available on the EVO® Electric Winch Range Size 40 to 80.

PART NUMBER	DESCRIPTION	40ST	45ST	50ST	55ST	65ST	70-70/3	80-80/3
68000933	CONTACTOR 12V "E"	•	•	•				
68000934	CONTACTOR 24V "E"	•	•	•				
18000301	CONTACTOR BOX 12V "E"	•	•	•				
18000302	CONTACTOR BOX 24V "E"	•	•	•				
48000217	ELS CONTROL BOX TYPE 1-3	24V						
48000220	ELS CONTROL BOX TYPE 1-6		24V					
48000221	ELS CONTROL BOX TYPE 1-7			24V	24V			
48000222	ELS CONTROL BOX TYPE 1-8	12V				24V		
48000224	ELS CONTROL BOX TYPE 2-2		12V					
48000225	ELS CONTROL BOX TYPE 2-3			12V				
48000227	ELS CONTROL BOX TYPE 2-5				12V			
48000229	ELS CONTROL BOX TYPE 2-7					12V		
48000178	70-70/3 CONTROL BOX 12V "ELS"						•	
48000179	70-70/3 CONTROL BOX 24V "ELS"						•	
48000180	80-80/3 CONTROL BOX 12V "ELS"							•
48000181	80-80/3 CONTROL BOX 24V "ELS"							•



Contactor "E"



"ELS" Electric Load Sensing Control Box

#### Circuit Breaker

CIRCUIT BREAKER		WINCH SIZE								
		40	45	50	55	65	70	80	90	110
68000542	40A	24V								
68000348	50A		24V							
68000240	70A			24V			24V	24V		24V
68000349	90A	12V			24V	24V			24V	
68000350	110A		12V							
68000239	120A			12V			12V			12V
68000351	150A							12V	12V	
68000894	200A				12V	12V				





## 4 Accessories

### Switches

#### CHSX Foot Switch

- Suitable for DC electric winches running on 12 or 24v
- IP67/5 rated for water resistance
- Twin sealed switch compartment
- Composite plastic body
- Available with polished stainless steel or composite plastic lid
- New lower-profile design with updated styling



#### CHSX Dimensions

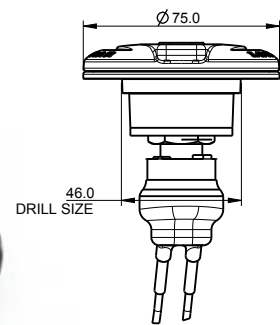

DESCRIPTION	BLACK	STAINLESS STEEL
CLOSED LID	68001249	68001257
OPEN LID	68001256	68001258

#### Custom Deck Switches

Lewmar has developed a new range of stylish Custom deck switches. The new Custom deck switch can be used for any winch or windlass application.

- Sealed switch with strong rubber button cover
- Stainless steel main body
- Polished or blasted finishes as standard (custom finishes available)
- Easy replacement of bellows
- Must be used with a contactor or control box



#### Custom Deck Switch Dimensions

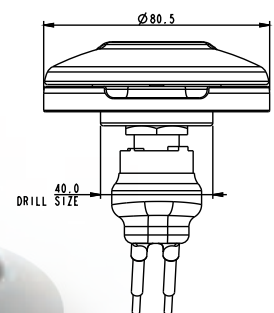

DESCRIPTION	MIRROR POL (MIRROR FINISH)	BLASTED (MATTE FINISH)
CLOSED	48000257	48000259
OPEN	48000256	48000258

## 6. Winch

### Servicing Your Winch



- |                  |                             |
|------------------|-----------------------------|
| 1. Top Cap       | 10. Drum                    |
| 2. Feeder arm    | 11. Roller bearing assembly |
| 3. Collet        | 12. Drum washer             |
| 4. Upper crown   | 13. Gear spindle sleeve     |
| 5. Stripper ring | 14. Pawl gear               |
| 6. Lower crown   | 15. Gear spindle            |
| 7. Spring        | 16. Centre stem             |
| 8. Spring cup    | 17. Pawl spring (not shown) |
| 9. Main spindle  | 18. Pawl                    |
|                  | 19. Ratchet gear            |

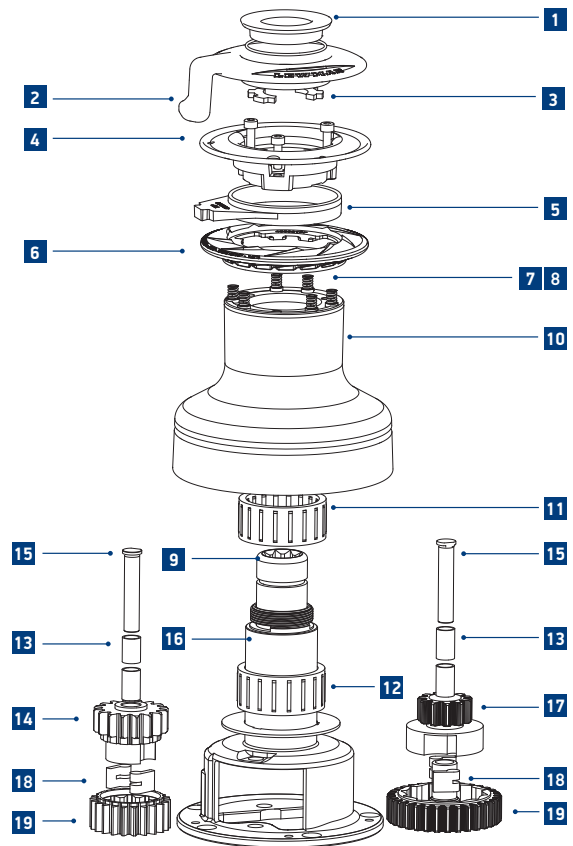

#### Frequency of servicing

Lewmar winches must be serviced regularly. Winches are required to carry deceptively high loads. Regular servicing, with attention to correct assembly and condition of parts, is vital to the safety and performance of your boat.

#### When?

- Two or three times during active sailing season winches should be stripped, cleaned and re-lubricated.
- At the end of each sailing season and before starting the new sailing season all Lewmar winches should be completely stripped, cleaned, thoroughly checked for damage and lubricated. (see the latest issue of the Lewmar Winch Service Manual available at [www.lewmar.com](http://www.lewmar.com))

#### External cleaning of the drum.

Chromed and stainless steel winches – wash drum regularly with fresh water and dry with a cloth. Non-abrasive liquid chrome cleaner can be used occasionally to remove dirt spots.

Alloy winches – wash drum regularly with fresh water and dry with a cloth. DO NOT use polishes or abrasives.

#### Servicing Winches

All components should be removed and cleaned in a paraffin bath during the course of servicing. If you do not have access to a paraffin bath, use half of an old plastic container with an old toothbrush. Even a cotton cloth soaked in paraffin or white spirit will suffice.

#### Caution

Some Lewmar winches contain plastic components which may be damaged by inappropriate cleaning agents. Always check the manufacturers directions before using any cleaning agents.

#### Greasing

Never use grease to lubricate your pawls, as this can lead to pawls sticking in their pockets and disabling the winch. Instead, lubricate with a light engine oil.

Use only a light smear of winch grease when lubricating ratchet tracks, gear teeth and bearings. Otherwise excess grease will be forced out and collect in potentially dangerous areas, such as pawl pockets.

#### Assembly

Winches must be re-assembled in the reverse sequence to the order of dismantling. After re-assembly, immediately check the winch functions correctly.

#### Mounting

Winches must be fitted as explained in the product manual (supplied with every winch and downloadable from [www.lewmar.com](http://www.lewmar.com)).

Winches are self-draining and care should be taken to ensure the drain holes are not obstructed.

#### Ratchet Gears – Pawl Engagement

When assembling ratchet gears, check pawl engagement as shown below. Incorrect assembly will lead to back winding of the winch. This is very dangerous, so extreme care should be taken.



✘ Wrong



✔ Correct

## Winch Maintenance Kits

Lewmar offers a full range of winch spares. Service kits include all common servicable spares including pawls, springs, sleeves, o-rings etc.

Full details of winch spares, including exploded diagrams to aid identification, are available from the spares section of [www.lewmar.com](http://www.lewmar.com)



**48000014**

**Suitable for**

- Ocean Standard winch sizes 6-40
- Ocean ST winch sizes 14 & 16
- EVO ST winch size 15



**48000019**

**Suitable for**

- Ocean ST winch sizes 30-48
- EVO ST winch sizes 30-50



**48000017**

**Suitable for**

- Ocean ST winch sizes 50-65
- EVO ST winch sizes 55-65



**48000018**

**Suitable for**

- Ocean ST winch size 68
- EVO ST winch size 70



**19701500**

**Winch Maintenance Pack**

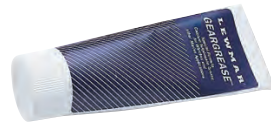

**19701000**

**Grease — 100g**



**19701100**

**Grease - 300g**



**19701600**

**Race Lube -55ml**

### Winch Spares Kits

A full range of spares kits are also available, from bearing packages to jaw kits and everything in between. Contact your local Lewmar supplier or visit the spares section of [www.lewmar.com](http://www.lewmar.com)

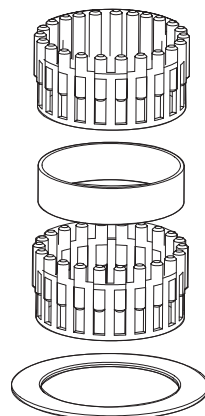

Drum Bearing Kit

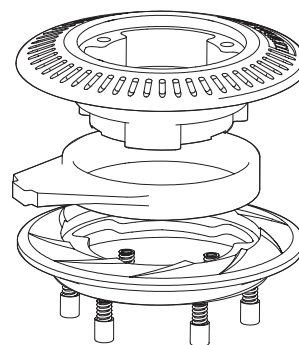

Jaw Kit

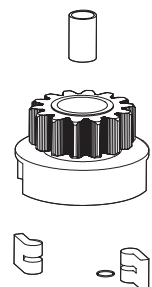

Pawl Gear Kit

## 6. Winch



### Custom Winches

For 50 years, Lewmar has been at the forefront of winch design and manufacture, featuring on cruisers to superyachts and Grand Prix racing boats.

Lewmar winches can be customised to suit individual aesthetic and functional requirements, with options including ceramic drum coatings, self-tailing jaws, custom top cleats, multiple speeds, free-spinning or ratcheting sheave base additions, and anticlockwise rotations. Each Lewmar winch is available in a choice of polished stainless steel, aluminium, or an individually specified finish, subject to discussion with your Lewmar representative.

- Cutting edge performance combined with classic styling
- Choice of styling includes rolex and bespoke engraving
- Individual functions to suit requirements, including sheave base, cleat or flat-top and self-tailing configurations
- Compatible with load-pin technology
- Ability to customise gear ratio and hydraulic motors to specific line requirements
- Electric or hydraulic operation options
- Available in bronze-effect finish
- Available in size 68 to size 150



### Custom Winch Specifications

PART NO	MODEL	FINISH	LINE SIZE	
			MM	IN
49088104	88HST OCEAN WINCH	STAINLESS STEEL	12-25	1/2-1
49088248	88 FLAT TOP WINCH	STAINLESS STEEL	12-25	1/2-1
49088109	88/3HST OCEAN	STAINLESS STEEL	12-25	1/2-1
49111104	111HST OCEAN	STAINLESS STEEL	16-38	5/8-1 1/2
49111109	111/3HST OCEAN	STAINLESS STEEL	16-38	5/8-1 1/2
49111255	111/3 FLAT TOP	STAINLESS STEEL	16-38	5/8-1 1/2
49122104	122HST OCEAN	STAINLESS STEEL	16-38	5/8-1 1/2
49122121	122/3 FLAT TOP	STAINLESS STEEL	16-38	5/8-1 1/2

As superyacht design trends evolve, so too must the look and feel of the equipment fitted to them. With current design tastes in mind, Lewmar has redesigned its custom range of winches to offer a cleaner, more streamlined look.

This parts list table contains just a fraction of the custom winches available. To assist with individual projects, our team of experts are on hand to help in selecting the perfect winch for the specific requirements.

Please email [custom@lewmarm.com](mailto:custom@lewmarm.com) with any enquiries.



## ASTOR Custom Winches

Lewmar manufactures cutting-edge alloy winches for larger yachts in which ultra-modern features and technical innovation are combined with classical looks.

ASTOR winches utilise a strong centre stem made of steel and aluminium and highly rigid Torlon® roller bearings. Lewmar has the capability to produce winch drums with specially milled surfaces to increase the grip. ASTOR winches are up to 30% lighter than a traditionally built winch of alloy and steel.

- Drive train based upon the proven Lewmar Ocean Range
- Available in size 40 to size 150
- Electric and hydraulic options available
- Lightweight aluminium construction

For further details contact [custom@lewmar.com](mailto:custom@lewmar.com)



### ASTOR Winch Specifications

PART NO	MODEL	FINISH	GEAR RATIO				POWER RATIO				WEIGHT		<b>D</b> DRUM DIA		<b>B</b> BASE DIA		<b>H</b> HEIGHT		<b>L</b> LINE ENTRY		LINE SIZE	
			1ST	2ND	3RD	4TH	1ST	2ND	3RD	4TH	KG	LB	MM	IN	MM	IN	MM	IN	MM	IN	MM	IN
49040050	40STR	BLACK	1.9:1	5.8:1	-	-	13.2:1	40.2:1	-	-	3.4	7.5	74	2 <sup>15</sup> / <sub>16</sub>	148	5 <sup>13</sup> / <sub>16</sub>	173	6 <sup>13</sup> / <sub>16</sub>	80	3 <sup>1</sup> / <sub>8</sub>	8-12	5 <sup>1</sup> / <sub>16</sub> -1 <sup>1</sup> / <sub>2</sub>
49044050	44STR	BLACK	2.4:1	7.6:1	-	-	13.9:1	44.8:1	-	-	4.9	10.8	87	3 <sup>7</sup> / <sub>16</sub>	168	6 <sup>5</sup> / <sub>8</sub>	192	7 <sup>9</sup> / <sub>16</sub>	84	3 <sup>5</sup> / <sub>16</sub>	8-14	5 <sup>1</sup> / <sub>16</sub> -9 <sup>1</sup> / <sub>16</sub>
49044014	44/3AOR	GREY	1:1	3:1	8.7:1	-	5.1:1	15.2:1	44:1	-	5.5	12.1	100	3 <sup>15</sup> / <sub>16</sub>	184	7 <sup>1</sup> / <sub>4</sub>	169	6 <sup>5</sup> / <sub>8</sub>	83	3 <sup>1</sup> / <sub>4</sub>	8-14	5 <sup>1</sup> / <sub>16</sub> -9 <sup>1</sup> / <sub>16</sub>
49048050	48STR	BLACK	2.6:1	9:1	-	-	13.9:1	48.6:1	-	-	5.9	13.0	93	3 <sup>1</sup> / <sub>16</sub>	181	7 <sup>1</sup> / <sub>8</sub>	208	8 <sup>3</sup> / <sub>16</sub>	86	3 <sup>3</sup> / <sub>8</sub>	8-14	5 <sup>1</sup> / <sub>16</sub> -9 <sup>1</sup> / <sub>16</sub>
49048015	48/3AOR	BLACK	1:1	3.6:1	10.6:1	-	4.5:1	16.3:1	48:1	-	6.8	14.9	112	4 <sup>7</sup> / <sub>16</sub>	207	8 <sup>1</sup> / <sub>8</sub>	196	7 <sup>3</sup> / <sub>4</sub>	102	4	8-14	5 <sup>1</sup> / <sub>16</sub> -9 <sup>1</sup> / <sub>16</sub>
49050050	50STR	BLACK	2.8:1	10.5:1	-	-	13.8:1	50.6:1	-	-	7.8	17.2	105	4 <sup>1</sup> / <sub>8</sub>	200	7 <sup>7</sup> / <sub>8</sub>	238	9 <sup>3</sup> / <sub>8</sub>	106	4 <sup>3</sup> / <sub>16</sub>	8-16	5 <sup>1</sup> / <sub>16</sub> -5 <sup>5</sup> / <sub>8</sub>
49050015	50/3AOR	BLACK	1:1	5.4:1	12.8:1	-	31.1:1	20.9:1	49.9:1	-	8.4	18.4	130	5 <sup>1</sup> / <sub>8</sub>	225	8 <sup>7</sup> / <sub>8</sub>	223	8 <sup>3</sup> / <sub>4</sub>	120	4 <sup>3</sup> / <sub>4</sub>	8-16	5 <sup>1</sup> / <sub>16</sub> -5 <sup>5</sup> / <sub>8</sub>
49054050	54STR	BLACK	2.8:1	11.2:1	-	-	13.8:1	54:1	-	-	8.3	18.3	105	4 <sup>1</sup> / <sub>8</sub>	205	8 <sup>1</sup> / <sub>16</sub>	250	9 <sup>13</sup> / <sub>16</sub>	115	4 <sup>1</sup> / <sub>2</sub>	8-16	5 <sup>1</sup> / <sub>16</sub> -5 <sup>5</sup> / <sub>8</sub>
49058050	58STR	BLACK	3.1:1	13.5:1	-	-	13.5:1	58.1:1	-	-	10.2	22.4	118	4 <sup>5</sup> / <sub>8</sub>	228	9	266	10 <sup>1</sup> / <sub>2</sub>	118.5	4 <sup>1</sup> / <sub>16</sub>	8-18	5 <sup>1</sup> / <sub>16</sub> -11 <sup>1</sup> / <sub>16</sub>
49060015	60/3AOR	BLACK	1:1	5.4:1	9:1	-	3.1:1	16.7:1	59.4:1	-	13.6	26.9	162	6 <sup>3</sup> / <sub>8</sub>	238	9 <sup>3</sup> / <sub>8</sub>	315	12 <sup>3</sup> / <sub>8</sub>	164	6 <sup>7</sup> / <sub>16</sub>	8-18	5 <sup>1</sup> / <sub>16</sub> -11 <sup>1</sup> / <sub>16</sub>
49062050	62STR	BLACK	3.1:1	14.5:1	-	-	13.5:1	62.6:1	-	-	10.8	23.8	118	4 <sup>5</sup> / <sub>8</sub>	231	9 <sup>1</sup> / <sub>8</sub>	271	10 <sup>1</sup> / <sub>16</sub>	121.5	4 <sup>3</sup> / <sub>4</sub>	8-18	5 <sup>1</sup> / <sub>16</sub> -11 <sup>1</sup> / <sub>16</sub>
49077035	77/3STR	GREY	2.8:1	8:1	27:1	-	7.9:1	23:1	77:1	-	22.3	49.1	178	7	294	11 <sup>9</sup> / <sub>16</sub>	348	8 <sup>3</sup> / <sub>4</sub>	174	6 <sup>7</sup> / <sub>8</sub>	12-22	1 <sup>1</sup> / <sub>2</sub> -7 <sup>7</sup> / <sub>8</sub>
49088245	88/3STR	GREY FLAT TOP	3.8:1	8:1	40:1	-	8.4:1	17.8:1	89:1	-	24.7	54.5	228	9	324	12 <sup>3</sup> / <sub>4</sub>	333	13 <sup>1</sup> / <sub>8</sub>	151	5 <sup>15</sup> / <sub>16</sub>	12-25	1 <sup>1</sup> / <sub>2</sub> -1
40000901	111/4AOR	GREY	1:1	3.6:1	8:1	45.2:1	1.8:1	6.5:1	14.6:1	89.2:1	29.1	64.2	280	11	404	15 <sup>15</sup> / <sub>16</sub>	317	12 <sup>1</sup> / <sub>2</sub>	163	6 <sup>7</sup> / <sub>16</sub>	12-25	1 <sup>1</sup> / <sub>2</sub> -1

## 6. Winch

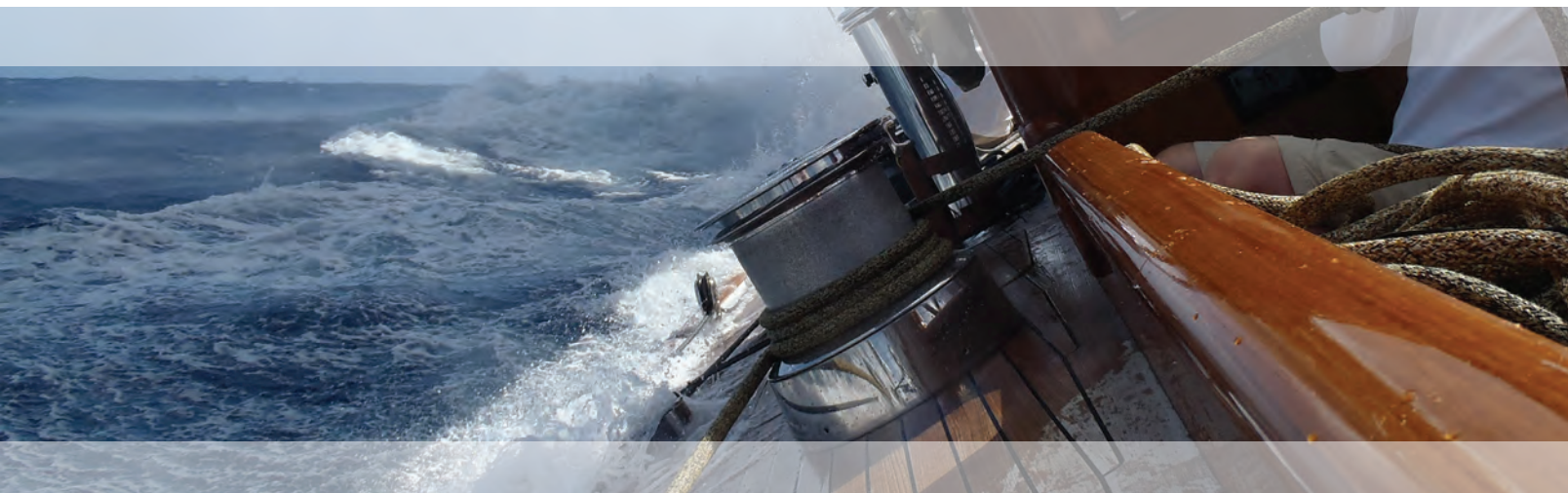

### 850/1150/1450 Backwind Winch

Lewmar has developed a full range of high-load, backwinding superyacht winches to cater for line loads up to 14.5T pull and 18T hold. Boats such as the awe-inspiring J-Class have long relied on Lewmar for their winch requirements and, as they continue to push the performance envelope, our design and engineering team have been challenged to keep up.

The range now includes the 1450, 1150 & 850 Backwind Winches, all featuring the same groundbreaking architecture. Twin output gears offer precise trimming and stability at high loads while the optimised gear ratios ensure high line speeds for manoeuvring. With the addition of the 850 to the range, performance cruisers of 80-100ft can now fit a backwinding primary.



850 Backwind

- 8.5T Max pull
- 10T Max hold



1150 Backwind

- 11.5T Max pull
- 15T Max hold

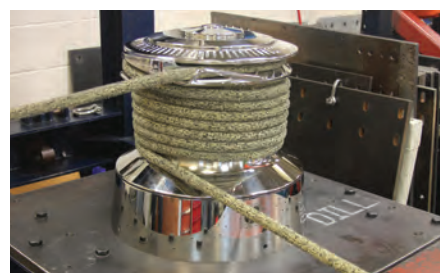

1450 Backwind

- 14.5T Max pull
- 18T Max hold



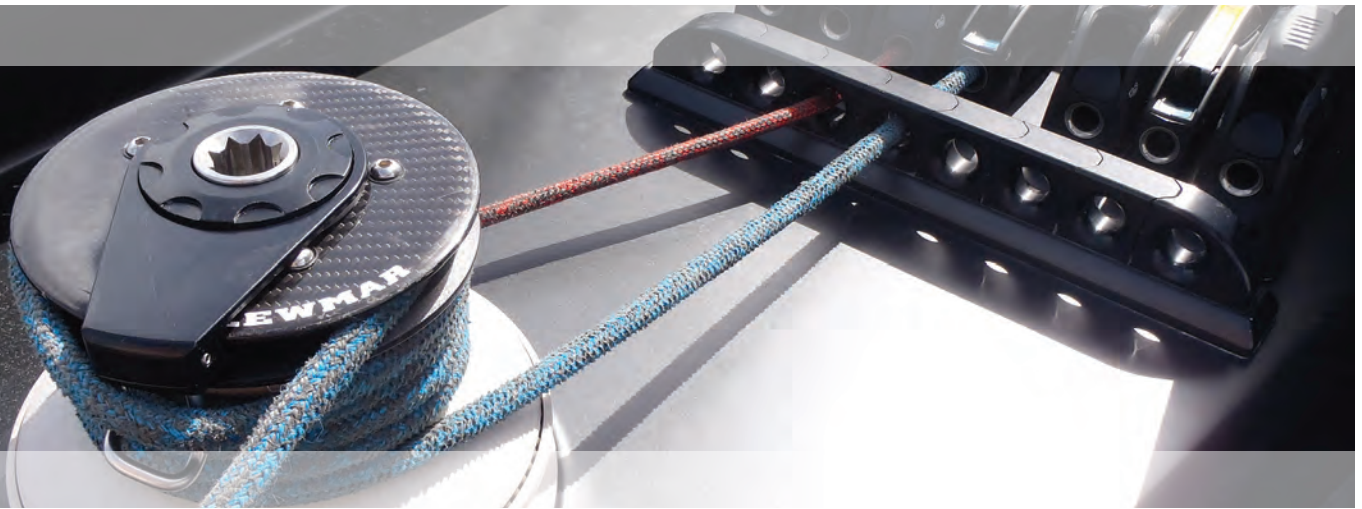

## Lewmar Race Winches

Lewmar Racing Winches have been at the forefront of the world's premier races for the last 60 years, including the America's Cup, Vendee Globe, MedCup, and the Volvo Ocean Race. Features such as aluminium and carbon fibre construction, Torlon® polymer bearings, and optional titanium gears, are the result of close relationships with race crews and cutting-edge research and design. Lewmar Racing Winches are the first choice for lightweight performance boats that want a winch they can rely on, whether round the cans or around the world.

Grand Prix racing winches can be driven by grinding pedestals or by hydraulic or electric motors. With modern racing rules evolving all the time, the Lewmar winch range has evolved to meet these challenges.

Pedestal-drive winch systems are used for applications demanding speed and power. One or more crew can grind from a powerful optimised standing position. Pedestal systems are customised to meet the specific needs of each boat.

- Latest Finite Element Analysis (FEA) and simulation software ensures designs are the lightest and most efficient winch systems
- Carbon power range available in Size 50 GPST through to the Size 120-4 GPST, with patented integral four-speed system
- Available with electric or hydraulic operation
- Operated by top handle or bottom pedestal drive
- Many custom options available, including ceramic drum coatings, custom top cleats, and free-spinning or ratcheting sheave base additions.
- Range available in 2 or 3 speed, or with Lewmar's patented integral 4-speed system
- State of the art carbon fibre finish offers weight saving
- Internal components crafted from aerospace industry materials
- Superior strength
- Developed through extensive research and development
- Custom speed and power ratios for ultimate flexibility
- Wavespring self-tailer
- Extensive range — self-tailing, cleat top, sheave base combinations

- A** Slam down 1:1 first speed button
- B** Carbon Tops & Skirts - Reducing weight
- C** Torlon Balls – More balls than any other winch!
- D** Wave Grip self-tailer – Proven, simple & effective design
- E** Drum Release – Unique single release button, for quick maintenance and servicing
- F** Large Torlon Bearings
- G** Sunk Base Option — For lower windage and flusher decks
- H** Internal Roller Bearings – For maximum efficiency
- I** Optimised Gear Design – Skeletal but strong

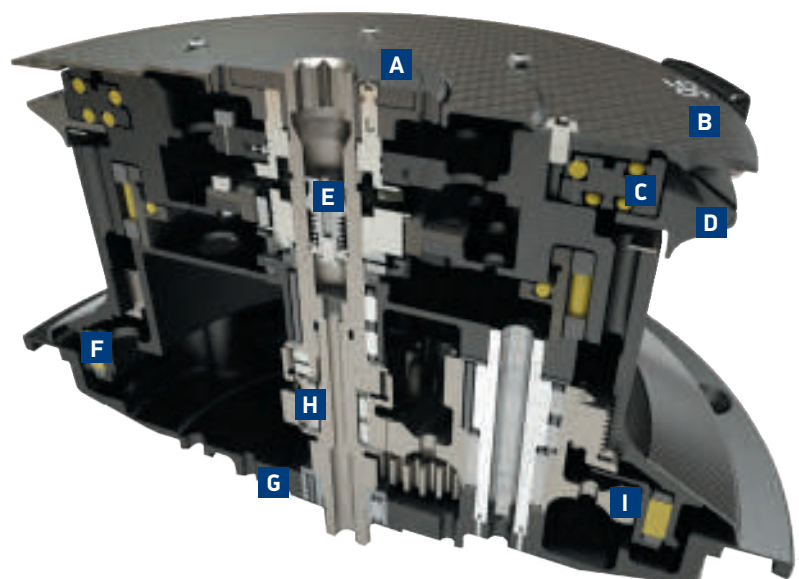

## 6. Winch

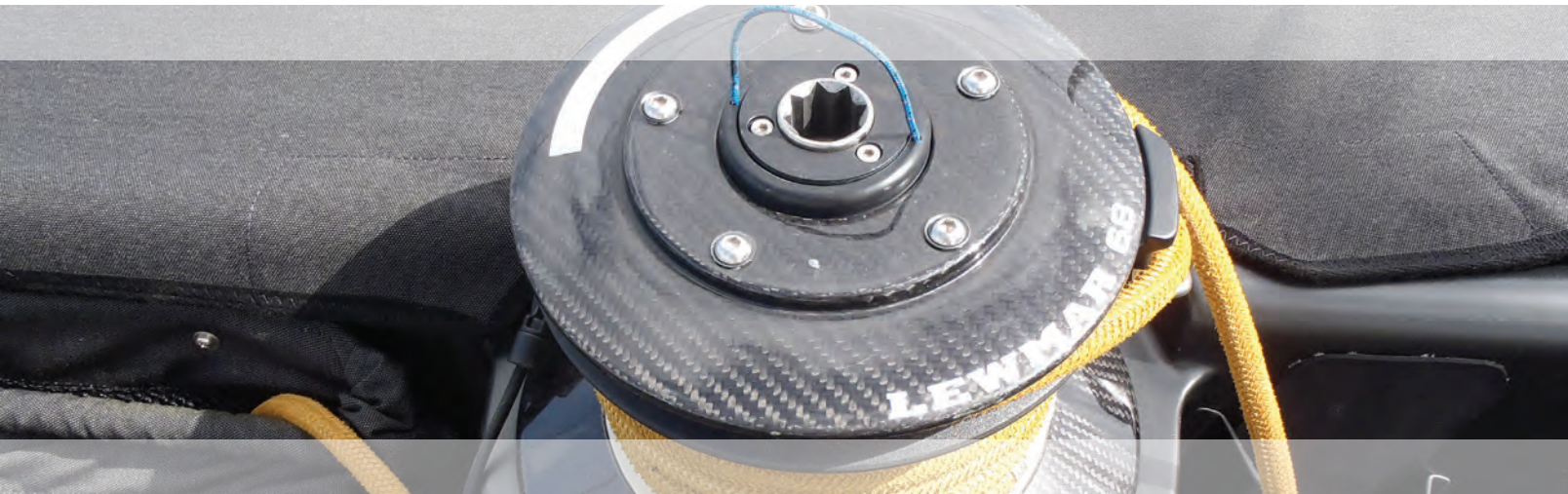

### Small Grand Prix Race Winches

Lightweight and strong, Lewmar's race winches offer the serious racer outstanding performance and power. Using the best features of our standard range, combined with the technology used on Fast 40+, Small Grand Prix Racing Winches offer performance and flexibility in lower-load applications.

All 3-Speed Grand Prix winches are available in either self-tailing, cleat top or sheave base configurations.

- Developed in conjunction with some of the top racing classes including, Fast 40+ and Kerr designs
- Range of finishes, including milled and keronite surfaces
- Driven manually, by power or through a pedestal

Dimensions Diagram Grand Prix Racing Winch

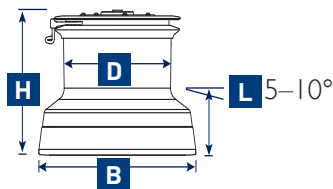

Grand Prix Racing Winch Specifications

PART NO	MODEL	GEAR RATIO				POWER RATIO				WEIGHT		D DRUM DIA		B BASE DIA		H HEIGHT		L LINE ENTRY		LINE SIZE	MOUNTING INSTRUCTIONS	
		1ST	2ND	3RD	4TH	1ST	2ND	3RD	4TH	KG	LB	MM	IN	MM	IN	MM	IN	MM	IN			
49050125	50GPST	3.4:1	11.3:1			15.2:1	50:1			4.7	10.3	115	4½	188	7¾	168	6⅝	62	2½	8-14	5/16-9/16	5 X M8 (5/16 IN) C'SK HEAD SCREWS ON 170MM (6⅝ IN) PCD
49050130	50GPST SR	3.4:1	11.3:1			15.2:1	50:1			5.1	11.2	115	4½	217	8½	168	6⅝	62	2½	8-14	5/16-9/16	5 X M8 (5/16 IN) C'SK HEAD SCREWS ON 170MM (6⅝ IN) PCD
49060000	60/3GPST	1:1	4.3:1	15.4:1		3.9:1	16.8:1	60.2:1		7.8	17.2	130	5½	214	8½	186	7¾	67	2⅝	8-14	5/16-9/16	6 X M8 (5/16 IN) C'SK HEAD SCREWS ON 195MM (7⅝ IN) PCD
49060009	60/3GP SB	1:1	4.3:1	15.4:1		3.9:1	16.8:1	60.2:1		8.2	18	130	5½	236	9⅓	186	7¾	67	2⅝	8-14	5/16-9/16	6 X M8 (5/16 IN) C'SK HEAD SCREWS ON 195MM (7⅝ IN) PCD
49068001	68ACSTR	3.5	19.2:1			12:1	67:1			9.5	20.9	150	5⅞	250	9⅓	213	8⅜	99	3⅞	8-14	5/16-9/16	6 X M10 (3/8 IN) C'SK HEAD SCREWS ON 200MM (7⅞ IN) PCD
49068160	68/3ACSTR	1:1	3.4:1	19.2:1		3.5:1	12:1	67:1		10.6	23.3	146	5¾	250	9⅓	227	8⅓	97	3⅞	8-14	5/16-9/16	6 X M10 (3/8 IN) C'SK HEAD SCREWS ON 200MM (7⅞ IN) PCD
49068021	68/3GP SB	1:1	3.5:1	19.3:1		3.5:1	12:1	67:1		10.5	23.1	146	5¾	275	10⅓	227	8⅓	95	3¾	8-14	5/16-9/16	6 X M10 (3/8 IN) C'SK HEAD SCREWS ON 200MM (7⅞ IN) PCD

SR - SPEED RING | ST - SELF TAILING | SB - SHEAVE BASE



## Large Grand Prix Race Winches

What's inside makes all the difference. In every Lewmar Grand Prix Winch, you will find materials developed for the aerospace industry, precision CNC machined for maximum efficiency, durability and strength-to-weight ratio. Once the winch is assembled, we use an aggressive in-house testing program to ensure maximum performance on the world's toughest racecourses.

- Developed in conjunction with some of the top racing classes including GP42, Class 40, TP52, Open 60, Volvo 70, IACC, 100ft Supermaxis and offshore Maxi-Multihulls
- Range available in 2, 3 or with Lewmar's integral 4-speed system

### Dimensions Diagram Grand Prix Racing Winch

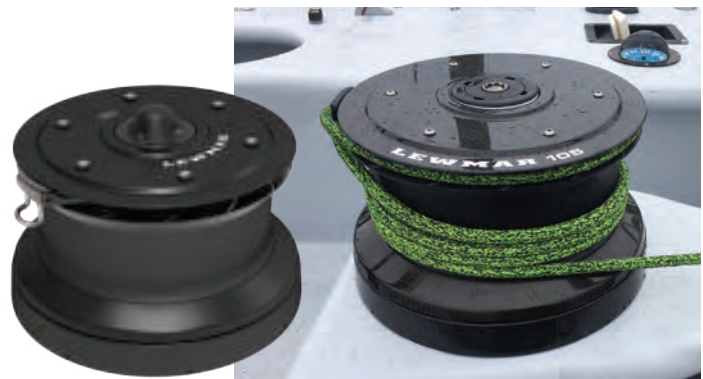
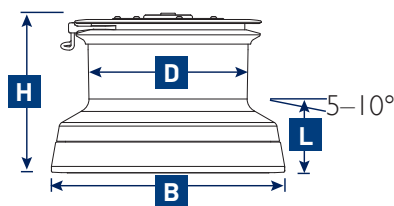

### Grand Prix Racing Winch Specifications

PART NO	MODEL	GEAR RATIO				POWER RATIO				WEIGHT		D DRUM DIA		B BASE DIA		H HEIGHT		L LINE ENTRY		LINE SIZE		MOUNTING INSTRUCTIONS
		1ST	2ND	3RD	4TH	1ST	2ND	3RD	4TH	KG	LB	MM	IN	MM	IN	MM	IN	MM	IN	MM	IN	
49082000	82GPST	1:1	8.5:1	29:1		2.5:1	24:1	82:1		14.7	32.4	182	7 <sup>1</sup> / <sub>8</sub>	290	11 <sup>1</sup> / <sub>4</sub>	215	8 <sup>3</sup> / <sub>16</sub>	79.5	3 <sup>1</sup> / <sub>8</sub>	12-16	1/2-5/8	8 X M10 (7/8 IN) C'SK HEAD SCREWS ON 266MM (10 1/2 IN) PCD
49099000	99/36PST	1:1	9.4:1	40.9:1		2.5:1	23:1	101:1		17.5	38.5	204	8	320	12 <sup>5</sup> / <sub>8</sub>	234	9 <sup>1</sup> / <sub>4</sub>	90	3 <sup>1</sup> / <sub>2</sub>	10-16	3/8-5/8	8 X M10 (7/8 IN) C'SK HEAD SCREWS ON 296MM (11 3/8 IN) PCD
49099009	99/36P SB	1:1	9.4:1	40.9:1		2.5:1	23:1	101:1		19.2	42.2	204	8	328	12 <sup>5</sup> / <sub>16</sub>	234	9 <sup>1</sup> / <sub>4</sub>	92	3 <sup>9</sup> / <sub>16</sub>	12-16	1/2-5/8	8 X M10 (7/8 IN) C'SK HEAD SCREWS ON 281MM (11 1/16 IN) PCD
49095001	95/46PST	1:1	3.8:1	8:1	40:1	2:1	7.6:1	16:1	80:1	20.5	45.1	254	10	370	14 <sup>5</sup> / <sub>8</sub>	225	8 <sup>7</sup> / <sub>8</sub>	98	3 <sup>7</sup> / <sub>8</sub>	10-16	3/8-5/8	6 X M12 (1/2 IN) C'SK HEAD SCREWS ON 288MM (11 3/32 IN) PCD
49095004	95/46PST SB	1:1	3.8:1	8:1	40:1	2:1	7.6:1	16:1	80:1	21.8	48	254	10	370	14 <sup>5</sup> / <sub>8</sub>	225	8 <sup>7</sup> / <sub>8</sub>	98	3 <sup>7</sup> / <sub>8</sub>	10-16	3/8-5/8	6 X M12 (1/2 IN) C'SK HEAD SCREWS ON 288MM (11 3/32 IN) PCD
40005066	105/3STR	1:1	8.3:1	39.6:1		1.6:1	13.6:1	64.8:1		18.5	40.7	280	11	360	14 <sup>9</sup> / <sub>32</sub>	225	8 <sup>7</sup> / <sub>8</sub>	93.7	3 <sup>1</sup> / <sub>16</sub>	8-14	5/16-9/16	6 X M12 (1/2 IN) C'SK HEAD SCREWS ON 288MM (11 3/32 IN) PCD
49105002	105/46PST	1:1	3.8:1	8:1	40:1	1.8:1	6.9:1	14.5:1	72.6:1	21.6	47.5	280	11	370	14 <sup>5</sup> / <sub>8</sub>	237	9 <sup>3</sup> / <sub>8</sub>	90	3 <sup>1</sup> / <sub>2</sub>	10-16	3/8-5/8	6 X M12 (1/2 IN) C'SK HEAD SCREWS ON 288MM (11 3/32 IN) PCD
49105006	105/46P SB	1:1	3.8:1	8:1	40:1	1.8:1	6.9:1	14.5:1	72.6:1	23.4	51.5	280	11	370	14 <sup>5</sup> / <sub>8</sub>	220	8 <sup>5</sup> / <sub>8</sub>	90	3 <sup>1</sup> / <sub>2</sub>	10-16	3/8-5/8	6 X M12 (1/2 IN) C'SK HEAD SCREWS ON 288MM (11 3/32 IN) PCD
49115000	115/3ACSTR	1:1	8:1	45.2:1		1.8:1	14.8:1	82.2:1		39.3	86.5	282	11 <sup>1</sup> / <sub>8</sub>	432	17	327	12 <sup>7</sup> / <sub>8</sub>	152	5 <sup>5</sup> / <sub>16</sub>	12-18	1/2-3/4	10 X M12 (1/2 IN) C'SK HEAD SCREWS ON 365MM (14 3/8 IN) PCD
49120001	120/4ACSTR	1:1	3.6:1	8:1	45.2:1	1.7:1	6:1	13.5:1	75.3:1	47.3	104.1	305	12	450	17 <sup>3</sup> / <sub>4</sub>	312	12 <sup>1</sup> / <sub>4</sub>	143	5 <sup>5</sup> / <sub>8</sub>	14-20	9/16-3/4	10 X M12 (1/2 IN) C'SK HEAD SCREWS ON 365MM (14 3/8 IN) PCD

## 6. Winch



### Lewmar Pedestal Systems

Lewmar has been making pedestal systems for over 40 years working closely with some of the best teams and sailors, over this time we have gained a great knowledge and understanding – we know what it takes to get you over the line. Our design engineers can develop bespoke tailored systems to your exact requirements.

- Optimised layup schedule ensures maximum stiffness and efficiency
- Drive components manufactured in hard anodised aluminium and titanium or 17-4 PH stainless steel
- Ceramic and Torlon® bearings along with carbon-reinforced drive belts provide lightweight, maximum efficiency

#### Drive Shafts

Lewmar offers two types of drive shafts, either extruded splined aluminium drive shafts, or the more popular custom made carbon tubular drive shafts with bonded end fittings. The drive shaft choice is determined by load, cost, and weight considerations.

#### Disconnect Foot Switches

Pedestal system disconnects can be activated with either levers, control lines or a two-position push button. The most popular method is operation via a foot switch.

#### Clutches

The unique Lewmar dog drive clutches ensure consistent and smooth operation. This allows engagement and disengagement even while the grinders are hard at work spinning the handles.

#### Overdrive Box

The overdrive box can be used to increase line speeds or heighten power, ideal for fast leeward mark rounding, or short handed sailing if you need more power. The Lewmar overdrive box is modular and can be fitted to any pedestal drive system.



PRODUCT	WEIGHT	
	KG	LB
MODULAR SELF SEEKING CLUTCH	2.4	5.3
INTEGRATED SELF SEEKING CLUTCH	0.75	1.6

PRODUCT	WEIGHT	
	KG	LB
OVERDRIVE BOX	3.1	6.8

## Rotor Pedestal

The new rotor pedestal is over 2kg lighter and is stiffer than its predecessor thanks to the more aggressive I-beam section and use of high-modulus carbon fibre. Large diameter Torlon® roller bearings have been used in the top end to support the high torque and axial loading which occurs during grinding. The top end is removable, making it easy to service from above deck. The complete internals can be disassembled, serviced and put back together within 30 minutes. This also means that the gear ratio can be easily changed on the water to suit the type of racing on the day.

## Universal Joints

Gear boxes are connected to other gear boxes and pedestals by drive shafts fitted with either a universal joint or a coupling at each end. Our CV couplings are extremely light but may only be used where the shafts are in-line. Our high-angle universal joint is made of aluminium with 17-4 stainless pins, making it very strong and able to operate efficiently at shaft angles up to 15 degrees.

## CV Joints

The Lewmar constant velocity joint can replace universal joints reducing weight in the system as well as increasing drive train efficiency for more effective power transfer.

## Bevel box

The bevel gear box is the core building block of the Lewmar drive system. Precision engineered and oil-filled, Lewmar bevel boxes transmit torque with extremely high efficiency, allowing maximum power delivery to the winches.

PRODUCT	WEIGHT	
	KG	LB
ALLOY BEVEL GEARBOX	4.5	10
LIGHTWEIGHT 4 MAN ALLOY BEVEL GEARBOX	2.5	5.5
HIGH TORQUE ULTRALIGHT CARBON FIBRE BEVEL GEARBOX	2.0	4.4



## 6. Winch



### Lewmar Rotor Pedestal

The new rotor pedestal is over 2kg lighter and is stiffer than its predecessor thanks to the more aggressive I-beam section and use of high modulus carbon fibre. Large diameter Torlon® roller bearings have been used in the top end to support the high torque and axial loading which occurs during grinding. The top end is removable, making it easy to service from above deck. The complete internals can be disassembled, serviced and put back together within 30 minutes. This also means that the gear ratio can be easily changed on the water to suit the type of racing on the day.

- Lightweight carbon shell
- Developed using high-strength low-weight pre-preg carbon fibre composites from the FI industry
- Clear coat UV-stable protective lacquer is standard (painted options available)
- Internal composite bearing systems
- Double bearing systems on handle housing
- Carbon or composite racing grip handles



**rotor**



## Oil-Filled Bevel Box

Our new oil-filled bevel boxes are 15% lighter and considerably smaller than its predecessor. By using very hard precision roller bearings, and thin oil lubrication, the bevel boxes are very efficient, requiring very little maintenance due to the high-quality internal bearings and magnetic drain plugs. Integrated clutches can be mounted directly to the bevel box housings to save the weight of additional brackets in the installation.



## Overdrive Boxes

The overdrive units come with two ratio options: [1:1.8] and [1:2.8]

The box can be engaged to speed up the winches (less power) or in slow down the winches (more power). This feature allows optimal load management in different applications and conditions. These overdrive boxes can be mounted on the pedestal or in line, next to the first bevel box.

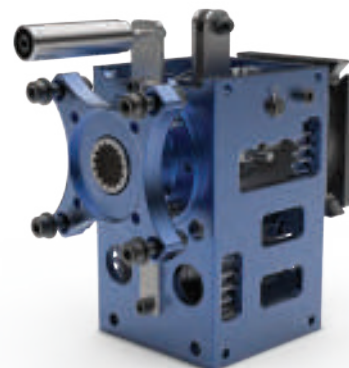

## Clutches and Disconnect Switches

The clutches have been simplified to make them lighter and easier to service with fewer parts. The small assemblies can be mounted to the bevel boxes, winches or pedestal to disconnect/connect exactly where needed in the system.



## 6. Winch



### CW 800 – The Captive Winch For The Smaller Yacht

The CW 800 winch is ideal for the main halyard or mainsheet on yachts. The CW 800 offers safe, remote-controlled line handling and storage on yachts up to 48ft (14.6m).

If you wish to have powered winches but do not have the space on the cabin top, using a CW 800 will allow the halyards to be hauled and stored in a convenient place on board for a very efficient use of space on smaller yachts.

Available in 12V and 24V options, the CW 800 is a viable alternative to managing halyards, or main sheets, dependent on the line speed required.

#### Dimensions Diagram CW 800

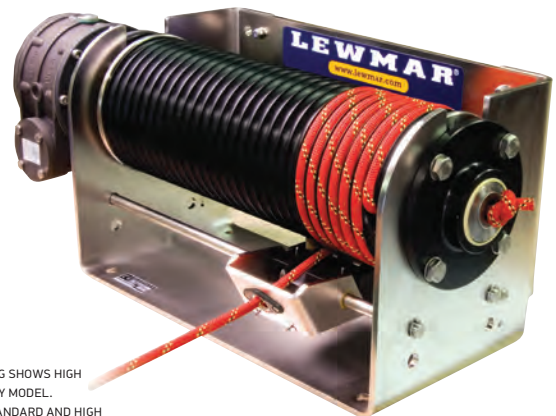
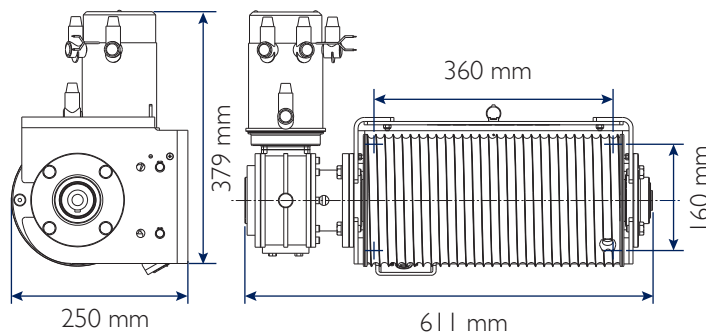

LINE DRAWING SHOWS HIGH CAPACITY MODEL. BOTH CW800 STANDARD AND HIGH CAPACITY VERSION HAVE THE SAME FOOTPRINT. THE DIFFERENCE IS THE DRUM DIAMETER

PART NUMBER	DESCRIPTION
59600140	CW800 WINCH 12V
59600142	CW800 WINCH 24V
59600150	CW800 HIGH CAPACITY WINCH 12V
59600152	CW800 HIGH CAPACITY WINCH 24V

#### CW 800 Standard Specification

SPECIFICATION	METRIC	IMPERIAL
MAX LINE LENGTH	10.3 M	34 FT
LINE SIZE	10 – 12 MM	3/8 – 7/16 IN
MAXIMUM LINE SPEED	33.5 M/MIN	110 FT/MIN
MAXIMUM PULL	800 KG	1760 LB
MAXIMUM HOLDING POWER	1500 KG	3307 LB
WEIGHT	38.5 KG	85E LB

#### CW 800 High Capacity Specification

SPECIFICATION	METRIC	IMPERIAL
MAX LINE LENGTH	14.6 M	48 FT
LINE SIZE	10 – 12 MM	3/8 – 7/16 IN
MAXIMUM LINE SPEED	45 M/MIN	148 FT/MIN
MAXIMUM PULL	500 KG	1102 LB
MAXIMUM HOLDING POWER	1500 KG	3307 LB
WEIGHT	39.3 KG	87 LB



## LMS - Captive Winch Line Management System

The Lewmar Captive Winch Line Management System offers safe, remote-controlled line handling and storage for yachts in the 22m (72ft) to 91m (300ft) range. The unique separate hauling drum eliminates the need for long lead entries, while storing the rope at low tension on a separate drum prevents damage to the rope. For small boats where space under the cabin top is limited, we have designed the CW800.

- Up to 25% lighter than previous models
- Compact size
- Up to 3 speed options
- Carbon stowage drum
- Eliminates long lead entry angles
- Can be used with proportional or non proportional hydraulic control systems
- Self sustaining – no load ‘drop back’ when the brakes are applied
- Pulls from 2.5 to 18 tons

A separate hauling drum eliminates the need for long lead entries while storing the rope to the separate storage drum, allowing the rope to be stored neatly at low tension and preventing damage to the rope and the possibility of riding turns.

**A** Unique V groove sheave improves grip and reduces rope damage

**B** Line stowing system ensures low line tension and good line lay

- Automatic hauling system
- Separate hauling and stowing drums, allows more rope storage for a given size
- Emergency high-load release feature

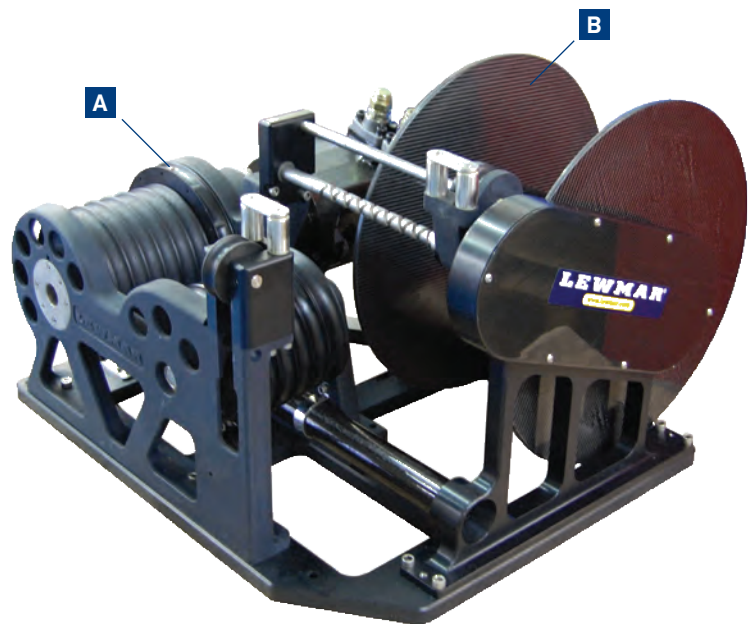

### LMS Standard Specifications

	SPEEDS	MAXIMUM LINE PULL		MAXIMUM LINE SPEED IN EACH GEAR		FLOW RATE AT MAX LINE SPEEDS		LINE DIAMETER		MAXIMUM WORKING PRESSURE		WEIGHT	
		KG	LB	M/MIN	FT/MIN	L/MIN	US GAL/MIN	MM	IN	BAR	PSI	KG	LB
CW2500	1	2500	5512	28	92	60	15.9	12-16	1/2-5/8	160	2321	120	265
CW3500	2	3500	7716	31/15	102/49	55	14.5	12-16	1/2-5/8	150	2176	120	265
CW6000	2 OR 3	6000	13228	60/24/15	197/79/49	45	11.9	14-22	9/16-7/8	235	3408	150	331
CW9000	2 OR 3	9000	19842	60/22/10	197/72/33	70	18.5	22-28	7/8-1/8	200	2901	285	628
CW12000	2 OR 3	12000	26455	60/20/13	197/66/43	95	25.1	26-30	1-1 <sup>3</sup> /16	230	3336	480	1058
CW18000	2 OR 3	18000	39683	60/16/10	197/52/33	110	29.1	30-38	1 <sup>3</sup> /16-1 <sup>1</sup> /2	220	3191	600	1323

MODEL	CW2500	CW3500	CW6000	CW9000	CW12000	CW18000
LINE STORAGE (M)	Ø12MM : 38	Ø12MM : 38	Ø14MM : 110	Ø20MM : 110	Ø26MM : 65	Ø30MM : 65
	Ø14MM : 29	Ø14MM : 29	Ø16MM : 90	Ø22MM : 85	Ø28MM : 55	Ø32MM : 55
	Ø16MM : 27	Ø16MM : 27	Ø18MM : 75	Ø24MM : 65	Ø30MM : 50	Ø34MM : 50
LINE STORAGE (FT)	Ø <sup>1</sup> / <sub>2</sub> " : 125	Ø <sup>1</sup> / <sub>2</sub> " : 125	Ø <sup>9</sup> / <sub>16</sub> " : 361	Ø <sup>13</sup> / <sub>16</sub> " : 361	Ø <sup>5</sup> / <sub>16</sub> " : 213	Ø <sup>3</sup> / <sub>16</sub> " : 213
	Ø <sup>9</sup> / <sub>16</sub> " : 95	Ø <sup>9</sup> / <sub>16</sub> " : 95	Ø <sup>5</sup> / <sub>8</sub> " : 295	Ø <sup>7</sup> / <sub>8</sub> " : 279	Ø <sup>1</sup> / <sub>2</sub> " : 180	Ø <sup>1</sup> / <sub>4</sub> " : 180
	Ø <sup>5</sup> / <sub>8</sub> " : 89	Ø <sup>5</sup> / <sub>8</sub> " : 89	Ø <sup>11</sup> / <sub>16</sub> " : 246	Ø <sup>15</sup> / <sub>16</sub> " : 213	Ø <sup>3</sup> / <sub>16</sub> " : 164	Ø <sup>5</sup> / <sub>16</sub> " : 164
			Ø <sup>13</sup> / <sub>16</sub> " : 197	Ø <sup>15</sup> / <sub>16</sub> " : 197	Ø <sup>1</sup> / <sub>4</sub> " : 148	Ø <sup>7</sup> / <sub>16</sub> " : 148
			Ø <sup>7</sup> / <sub>8</sub> " : 164	Ø <sup>15</sup> / <sub>16</sub> " : 164		

# 6. Winch

CW 2500

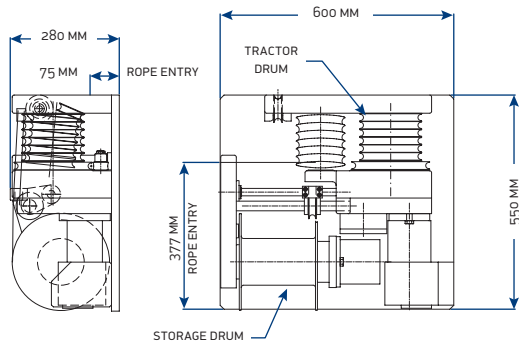

CW 3500

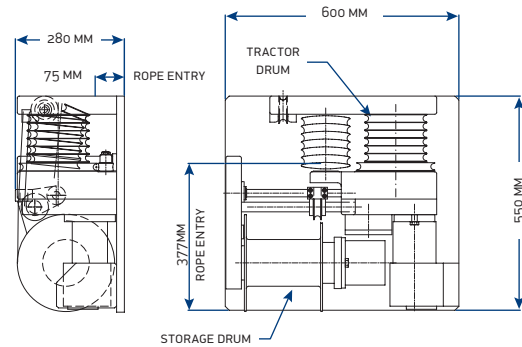

CW 6000

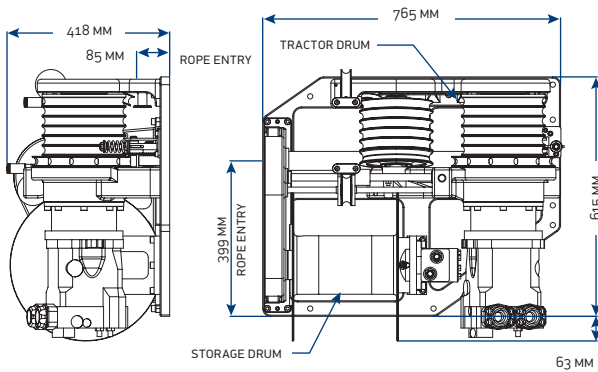

CW 9000

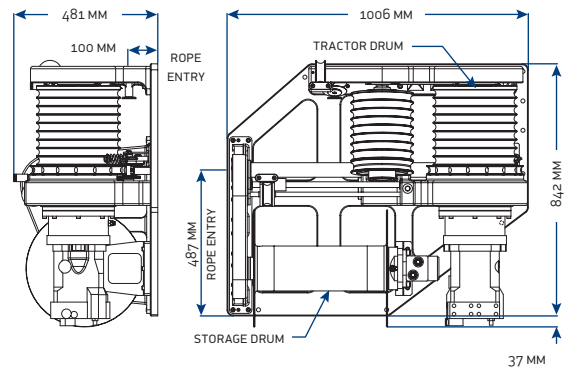

CW 12000

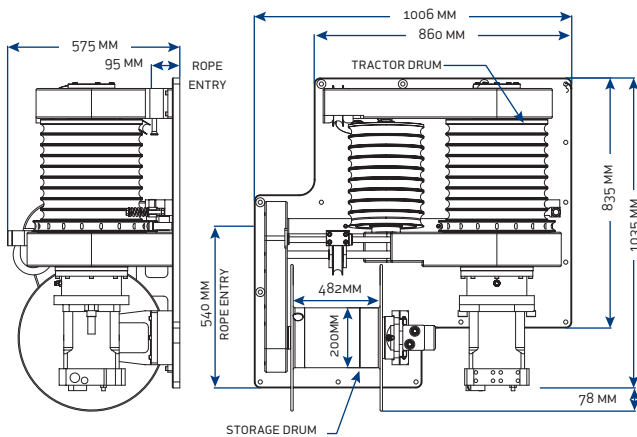

CW 18000

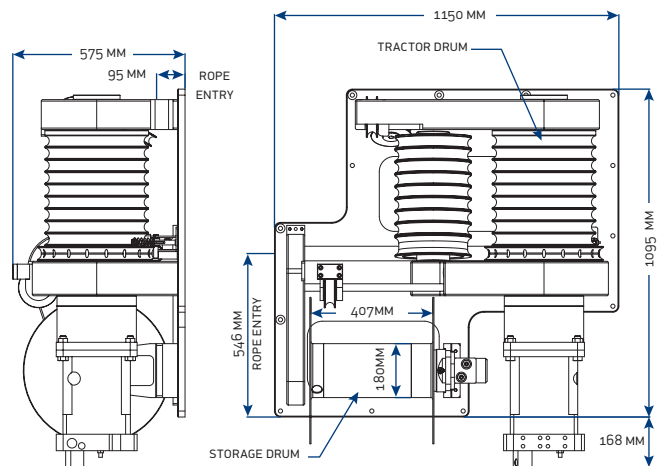

## Custom Line Storage

Custom line storage options available.

Contact [custom@lewmar.com](mailto:custom@lewmar.com) for more information





## Winch Handles

### OneTouch Winch Handle

The award-winning OneTouch allows you to lock in and remove the winch handle with one hand. Simply squeeze the release lever, which runs the entire length of the handle, and pull to unlock in one quick, easy motion.

- 8" and 10" Alloy Handle
- Release lever runs entire length of the handle
- Easy one-handed removal – just squeeze and lift
- Lightweight, forged construction
- Corrosion resistant for years of performance under harsh conditions
- Available in Standard Grip and Power Grip
- As used by the Americas Cup, Volvo and TP52 teams



### Specifications

PART NUMBER	SIZE		DESCRIPTION
	MM	IN	
29140044	250	10	ALLOY HANDLE, LOCK-IN, SINGLE GRIP
29140046	250	10	ALLOY HANDLE, LOCK-IN, POWER GRIP
29140040	200	8	ALLOY HANDLE, LOCK-IN, SINGLE GRIP
29140042	200	8	ALLOY HANDLE, LOCK-IN, POWER GRIP

## 6. Winch



### Lewmar Winch Handles

- Ball bearings provide maximum efficiency
- Manufactured in durable, lightweight alloy
- 250mm (10") available in chrome
- Optional Power Grip makes initial fast cranking easy and comfortable, with space for a second hand once the load comes on



### Titan Winch Handles

- Strong composite construction
- Very light-weight
- Handle floats if dropped overboard
- Engineered to withstand rigours of saltwater environment.



PART NUMBER	SIZE		DESCRIPTION
	MM	IN	
29145301	200	8	TITAN WINCH HANDLE, RED, LOCKING
29145311	250	10	TITAN WINCH HANDLE, RED, LOCKING
29140017	200	8	LEWMAR WINCH HANDLE, BLUE, NON-LOCKING



I5ST EVO® Winch spares

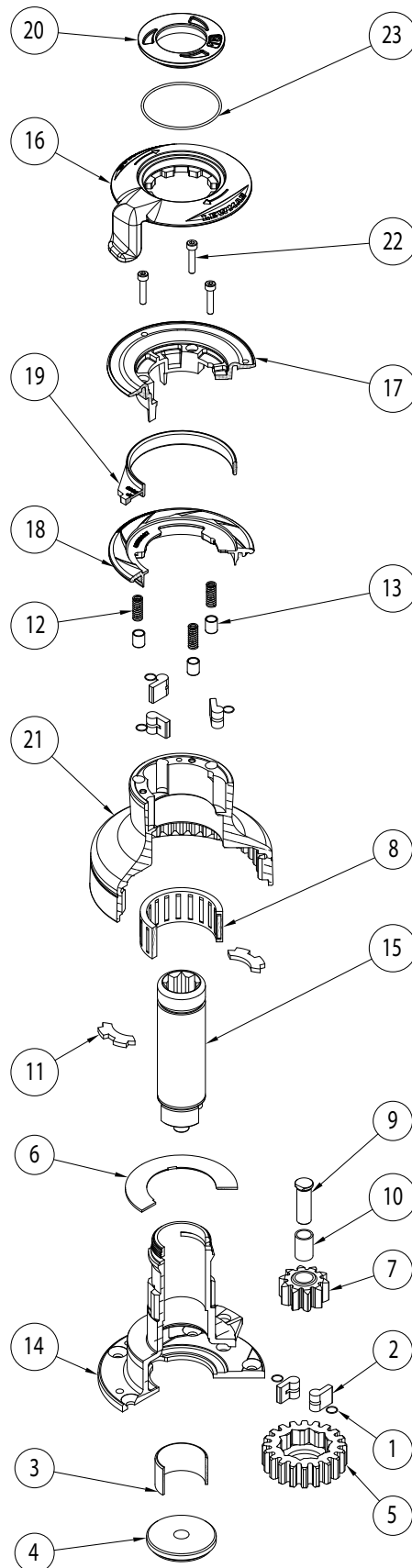

ITEM	PART NO	DESCRIPTION	QTY	KIT NO
1	1260/7	PAWL SPRING	5	48000014
2	1260/8	PAWL SMALL	5	48000014
3	15000377	BEARING SLEEVE	1	48000014
4	15000461	GEAR RETAINER	1	48300060
5	15000464	RATCHET GEAR	1	15000464
6	15000466	DRUM WASHER	1	48000454
7	15000827	IDLER GEAR	1	15000827
8	15008007	NEEDLE BEARING	1	48000454
9	45000023	GEAR SPINDLE	1	45000023
10	45000033	GEAR SPINDLE SLEEVE	1	48300060
11	45000102	COLLET	2	48000446
12	45000112	SPRING	3	48500016
13	45000113	SPRING CUP	3	48500016
14	48515017	CENTRE STEM	1	CONTACT DEALER
15	45500004	MAIN SPINDLE	1	CONTACT DEALER
16	45500005	FEEDER ARM	1	48500005
17	45500006	UPPER CROWN	1	48500016
18	45500007	LOWER CROWN	1	48500016
19	45500008	STRIPPER RING	1	48500016
20	45500009	TOP CAP	1	48500015
21	455000**	DRUM	1	CONTACT DEALER
22		M4X20LNG SKT HD CAP SCREW A2	3	48500016
23	B12988	O RING 50 X 1.5	1	48500015



40ST EVO® Winch spares

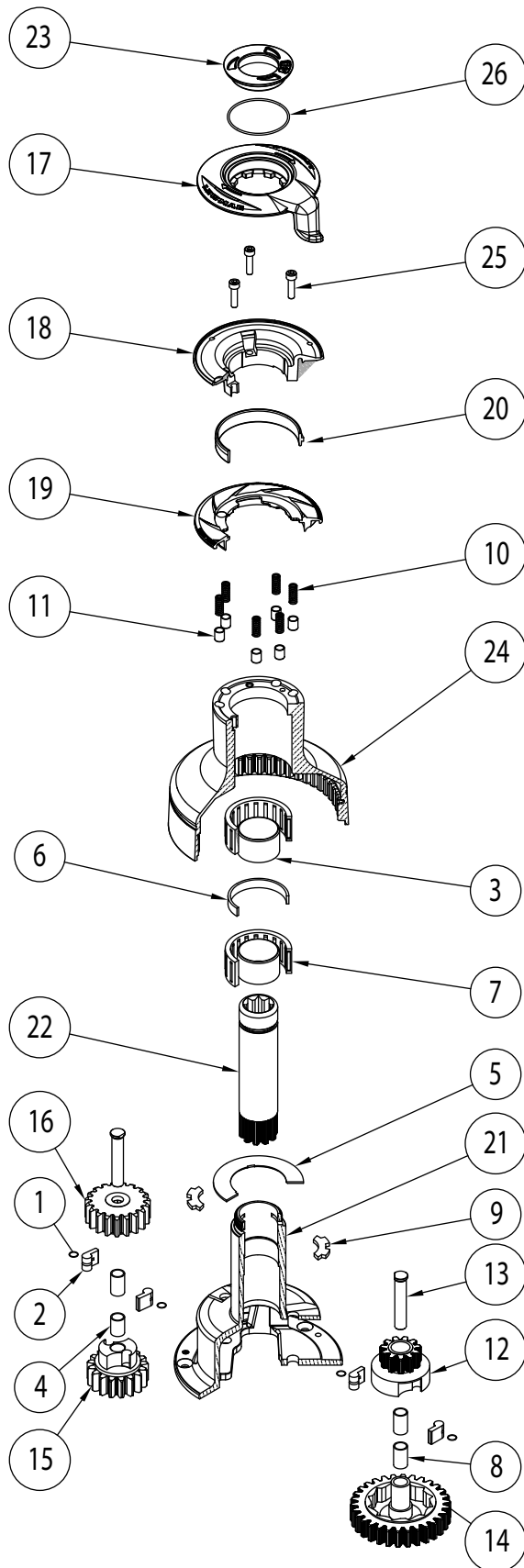

ITEM	PART NO	DESCRIPTION	QTY	KIT NO
1	1260/7	PAWL SPRING	4	48000019
2	1260/8	PAWL SMALL	4	48000019
3	15000377	BEARING SLEEVE	2	48000019
4	15000378	GEAR SPINDLE SLEEVE	1	48000467
5	15000466	DRUM WASHER	1	48000456
6	15000491	BEARING SPACER	1	48000456
7	15008007	NEEDLE BEARING	2	48000456
8	45000029	GEAR SPINDLE SLEEVE	3	48000464
9	45000102	COLLET	2	48000446
10	45000112	SPRING CUP	6	48500031
11	45000113	SPRING CUP	6	48500031
12	45000119	PAWL GEAR	1	48000464
13	45000123	GEAR SPINDLE	2	48300027
14	45000220	RATCHET GEAR	1	48300029
15	45000221	PAWL GEAR	1	48000467
16	45000222	RATCHET GEAR	1	45000222
17	45500105	FEEDER ARM	1	48500105
18	45500106	UPPER CROWN	1	48500031
19	45500107	LOWER CROWN	1	48500031
20	45500108	STRIPPER RING	1	48500031
21	48540017	CENTRE STEM	1	48540017
22	45500204	MAIN SPINDLE	1	45500204
23	45500209	TOP CAP	1	48500040
24	455002**	DRUM	1	CONTACT DEALER
25	M5X20 SKT HD CAP SCREW A2		3	48500031
26	B12987	O-RING 48X1.5	1	48500040



# 6. Winch

45ST EVO® Winch spares

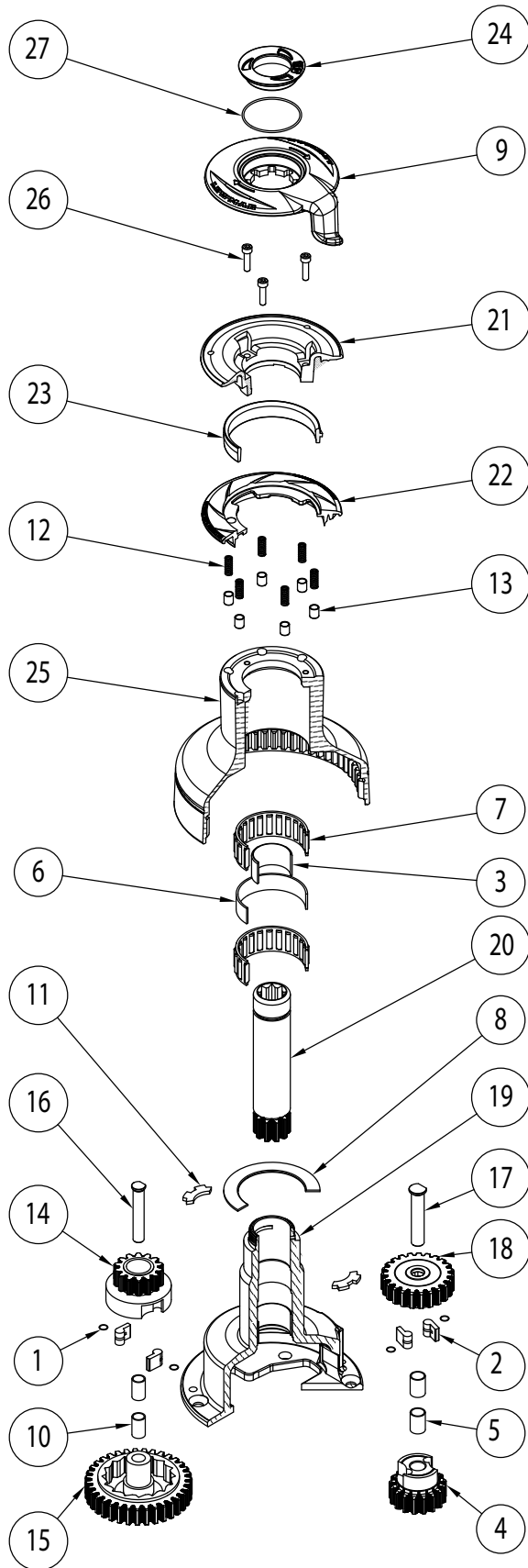

ITEM	PART NO	DESCRIPTION	QTY	KIT NO
1	1260/7	PAWL SPRING	4	48000019
2	1260/8	PAWL SMALL	4	48000019
3	15000377	BEARING SLEEVE	2	48000019
4	15000397	PAWL GEAR	1	48000468
5	15000398	SPINDLE SLEEVE	2	48000468
6	15000404	SPACER	1	48000457
7	15010007	ROLLER BEARING	2	48000457
8	15044116	DRUM WASHER	1	48000457
9	43500305	FEEDER ARM	1	48500305
10	45000029	GEAR SPINDLE SLEEVE	2	48000469
11	45000102	COLLET	2	48000446
12	45000112	SPRING	6	48500046
13	45000113	SPRING CUP	6	48500046
14	45000319	PAWL GEAR	1	48000469
15	45000320	RATCHET GEAR	1	48300036
16	45000323	GEAR SPINDLE	1	45000323
17	45000324	GEAR SPINDLE	1	45000324
18	45000333	RATCHET GEAR	1	45000333
19	48545017	CENTRE STEM	1	48545017
20	45500304	MAIN SPINDLE	1	45500304
21	45500306	UPPER CROWN	1	48500046
22	45500307	LOWER CROWN	1	48500046
23	45500308	STRIPPER RING	1	48500046
24	45500309	TOP CAP	1	48500045
25	455003**	DRUM	1	CONTACT DEALER
26		M5X20 SKT HD CAP SCREW A2	3	48500046
27	B12987	O-RING 48X1.5	1	48500045



50ST EVO® Winch spares

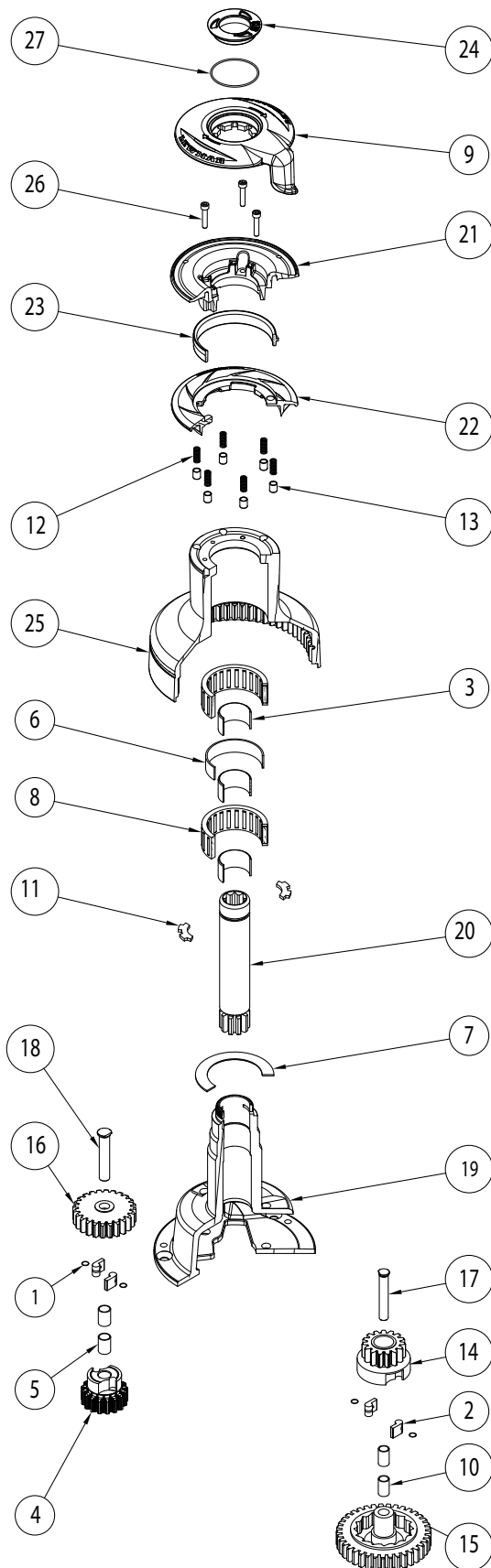

ITEM	PART NO	DESCRIPTION	QTY	KIT NO
1	1260/7	PAWL SPRING	4	48000019
2	1260/8	PAWL SMALL	4	48000019
3	15000377	BEARING SLEEVE	3	48000019
4	15000397	PAWL GEAR	1	48000468
5	15000398	SPINDLE SLEEVE	2	48000468
6	15000404	SPACER	1	48000458
7	15044116	DRUM WASHER	1	48000458
8	15044121	ROLLER BEARING	2	48000458
9	43500405	FEEDER ARM	1	48500405
10	45000029	GEAR SPINDLE SLEEVE	2	48000470
11	45000102	COLLET	2	48000446
12	45000112	SPRING	6	48500051
13	45000113	SPRING CUP	6	48500051
14	45000419	PAWL GEAR	1	48000470
15	45000420	RATCHET GEAR	1	48300043
16	45000422	RATCHET GEAR	1	45000422
17	45000423	GEAR SPINDLE	1	45000423
18	45000424	GEAR SPINDLE	1	45000424
19	48500017	CENTRE STEM	1	48500017
20	45500404	MAIN SPINDLE	1	45500404
21	45500406	UPPER CROWN	1	48500051
22	45500407	LOWER CROWN	1	48500051
23	45500408	STRIPPER RING	1	48500051
24	45500409	TOP CAP	1	48500050
25	455004**	DRUM	1	CONTACT DEALER
26		M5X20 SKT HD CAP SCREW A2	3	48500051
27	B12987	O-RING 48X1.5	1	48500050



# 6. Winch

55ST EVO® Winch spares

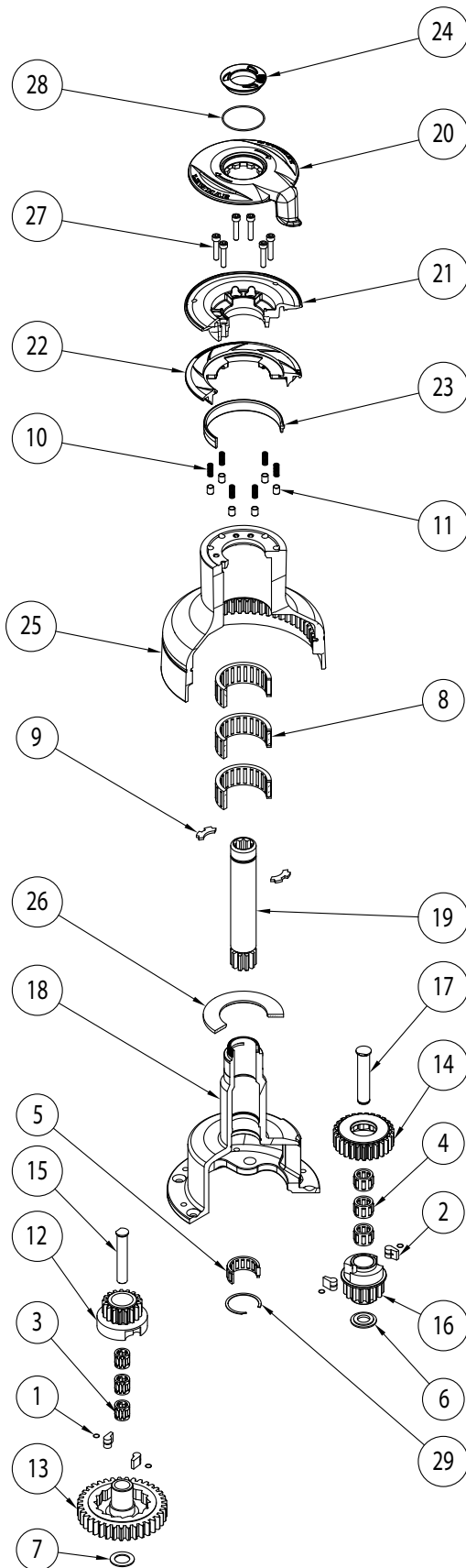

ITEM	PART NO	DESCRIPTION	QTY	KIT NO
1	1260/7	PAWL SPRING	4	48000017
2	1264/8	PAWL	4	48000017
3	1300-5A2	BEARING ASSY	3	48000017
4	15000017	ROLLER BEARING	3	48000473
5	15000019	ROLLER BEARING	1	48000019
6	15000646	WASHER	1	48000473
7	15000981	WASHER	1	48000017
8	15044121	ROLLER BEARING	3	48000460
9	45000102	COLLET	2	48000446
10	45000112	SPRING	6	48500056
11	45000113	SPRING CUP	6	48500056
12	45000519	PAWL GEAR	1	48000472
13	45000520	RATCHET GEAR	1	45000520
14	45000522	RATCHET GEAR	1	45000522
15	45000523	GEAR SPINDLE	1	45000523
16	45000621	PAWL GEAR	1	48000473
17	45000624	GEAR SPINDLE	1	45000624
18	48555017	CENTRE STEM	1	48555017
19	45500504	MAIN SPINDLE	1	45500504
20	45500505	FEEDER ARM	1	48500405
21	45500506	UPPER CROWN	1	48500056
22	45500507	LOWER CROWN	1	48500056
23	45500508	STRIPPER RING	1	48500056
24	45500509	TOP CAP	1	48500055
25	455005**	DRUM	1	CONTACT DEALER
26	45500513	DRUM WASHER	1	48000460
27		SKT HD CAP SCREW M6X30	6	48500056
28	B12988	O RING 50X1.5	1	48500055
29	B2092	CIRCLIP	1	48000017

65ST EVO® Winch spares

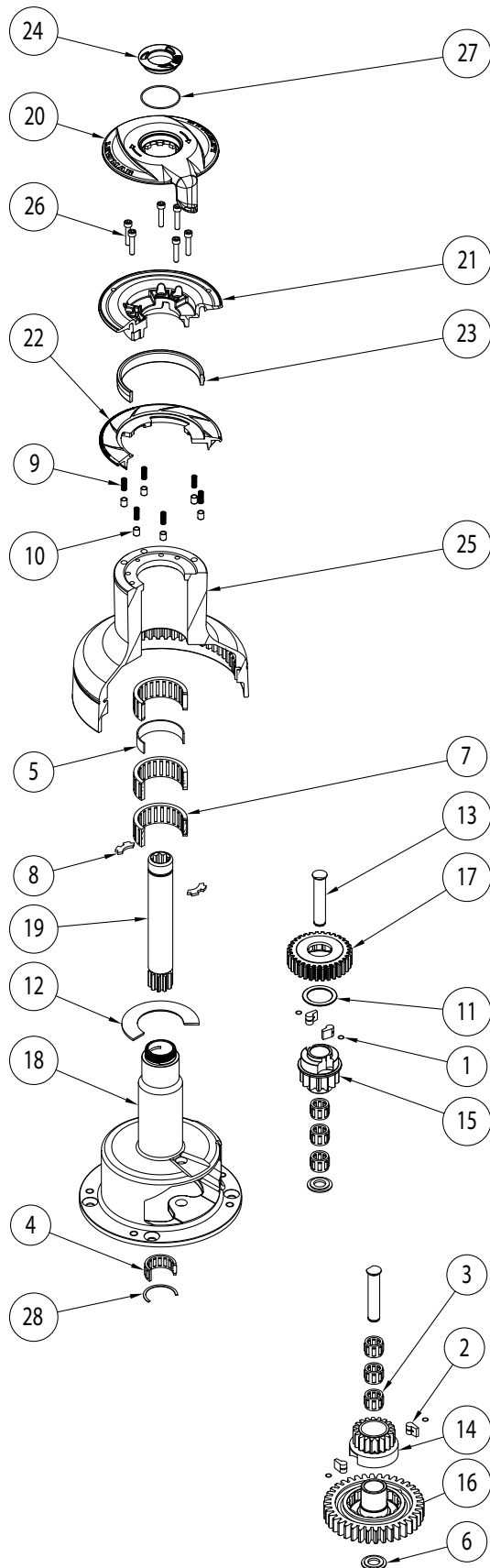

ITEM	PART NO	DESCRIPTION	QTY	KIT NO
1	1260/7	PAWL SPRING	4	48000017
2	1264/8	PAWL	4	48000017
3	15000017	ROLLER BEARING	6	48000017
4	15000019	ROLLER BEARING	1	15000019
5	15000404	SPACER	1	48000017
6	15000646	WASHER	1	48000017
7	15044121	ROLLER BEARING	3	48000462
8	45000102	COLLET	2	48000446
9	45000112	SPRING	6	48500066
10	45000113	SPRING CUP	6	48500066
11	45000533	WASHER	1	48000476
12	45000534	DRUM WASHER	1	48000462
13	45000624	GEAR SPINDLE	2	45000624
14	45000719	PAWL GEAR	1	48000475
15	45000821	PAWL GEAR	1	48000476
16	45000851	RATCHET GEAR	1	45000851
17	45005183	RATCHET GEAR	1	48000476
18	48565017	CENTRE STEM	1	48565017
19	45500604	MAIN SPINDLE	1	45500604
20	45500605	FEEDER ARM	1	48500605
21	45500606	UPPER CROWN	1	48500066
22	45500607	LOWER CROWN	1	48500066
23	45500608	STRIPPER RING	1	48500066
24	45500609	TOP CAP	1	48500065
25	455006**	DRUM	1	CONTACT DEALER
26		SKT HD CAP SCREW M6X30	6	48500066
27	B12987	O RING 48X1.5	1	48500065
28	B2092	CIRCLIP	1	48000017



# 6. Winch

I6ST Ocean Winch spares

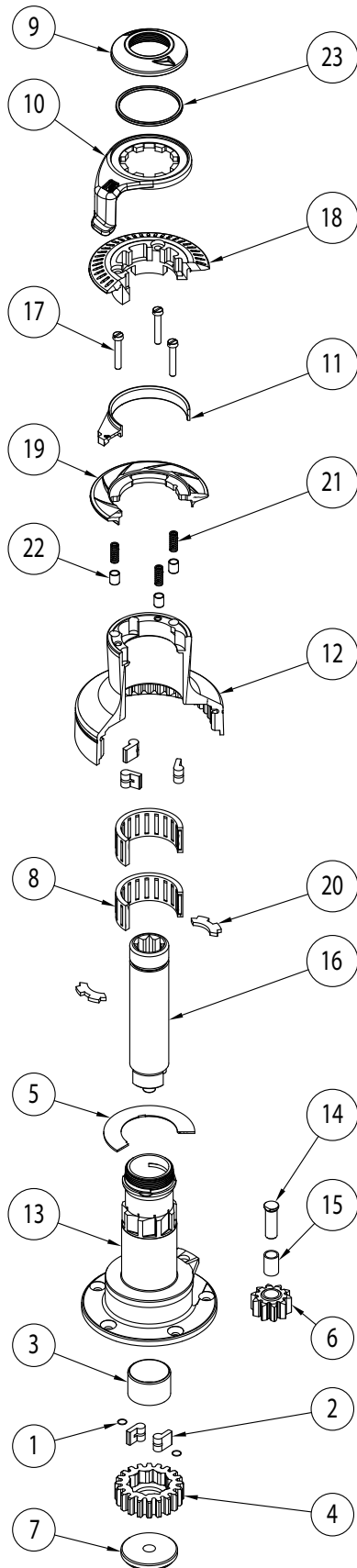

ITEM	PART NO	DESCRIPTION	QTY	KIT NO
1	1260/7	PAWL SPRING	5	48000014
2	1260/8	PAWL SMALL	5	48000014
3	15000377	BEARING SLEEVE	1	48000014
4	15000464	RATCHET GEAR	1	15000464
5	15000466	DRUM WASHER	1	48000454
6	15000827	IDLER GEAR	1	15000827
7	15000461	GEAR RETAINER	1	48300060
8	15008007	NEEDLE BEARING	2	48000454
9	450000**	TOP CAP	1	CONTACT DEALER
10	45000003	FEEDER ARM	1	48000478
11	45000008	STRIPPER RING	1	48000447
12	450000**	DRUM	1	CONTACT DEALER
13	48016017	CENTRE STEM	1	48016017
14	45000023	GEAR SPINDLE	1	45000023
15	45000033	GEAR SPINDLE SLEEVE	1	48500060
16	45000037	MAIN SPINDLE	1	45000037
17		M5X30 SLT CHS HD	3	48000447
18	45000085	UPPER CROWN	1	48000447
19	45000089	LOWER CROWN	1	48000447
20	45000102	COLLET	2	48000446
21	45000112	SPRING	3	48000447
22	45000113	SPRING CUP	3	48000447
23	B****	O RING	1	48000014

30ST Ocean Winch spares

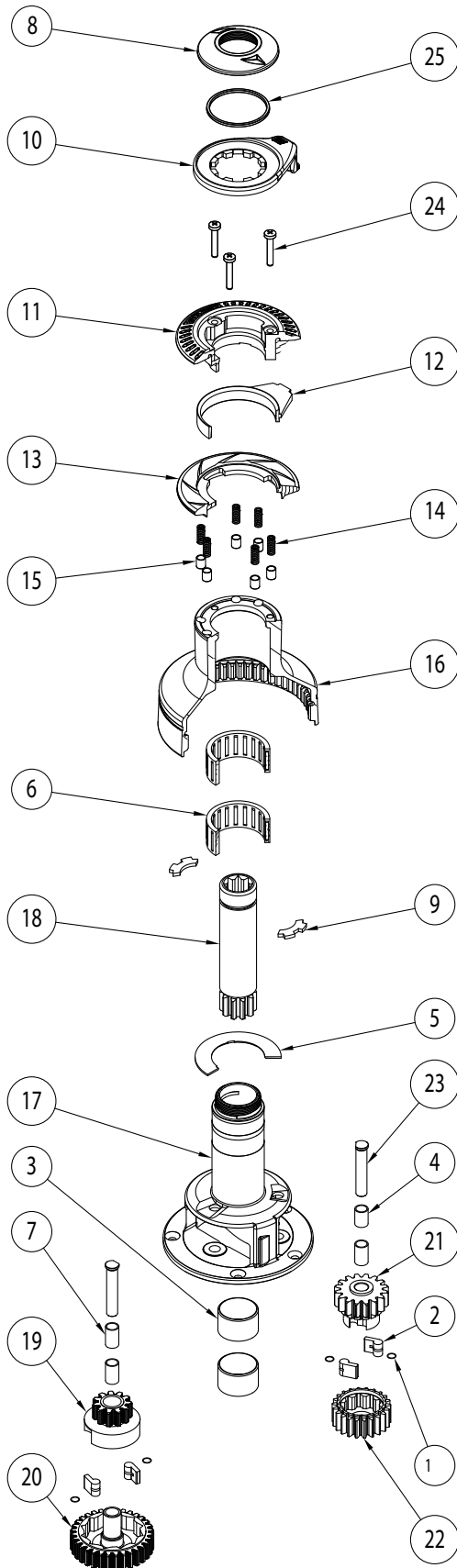

ITEM	PART NO	DESCRIPTION	QTY	KIT NO
1	1260/7	PAWL SPRING	4	48000019
2	1260/8	PAWL SMALL	4	48000019
3	15000377	BEARING SLEEVE	2	48000019
4	15000378	GEAR SPINDLE SLEEVE	1	48000465
5	15000466	DRUM WASHER	1	48000455
6	15008007	NEEDLE BEARING	2	48000455
7	45000029	GEAR SPINDLE SLEEVE	3	48000465
8	450001**	TOP CAP	1	CONTACT DEALER
9	45000102	COLLET	2	48000446
10	45000103	FEEDER ARM	1	48000480
11	45000105	UPPER CROWN	1	48000448
12	45000108	STRIPPER RING	1	48000448
13	45000109	LOWER CROWN	1	48000448
14	45000112	SPRING	6	48000448
15	45000113	SPRING CUP	6	48000448
16	4500011*	DRUM	1	CONTACT DEALER
17	48030017	CENTRE STEM	1	48030017
18	45000118	MAIN SPINDLE	1	45000118
19	45000119	PAWL GEAR	1	48000465
20	45000120	RATCHET GEAR	1	45000120
21	45000121	PAWL GEAR	1	48000465
22	45000122	RATCHET GEAR	1	48000465
23	45000123	GEAR SPINDLE	2	48300027
24		PAN HEAD SCREW	3	48000448
25	B****	O RING	1	48000019



# 6. Winch

40ST Ocean Winch spares

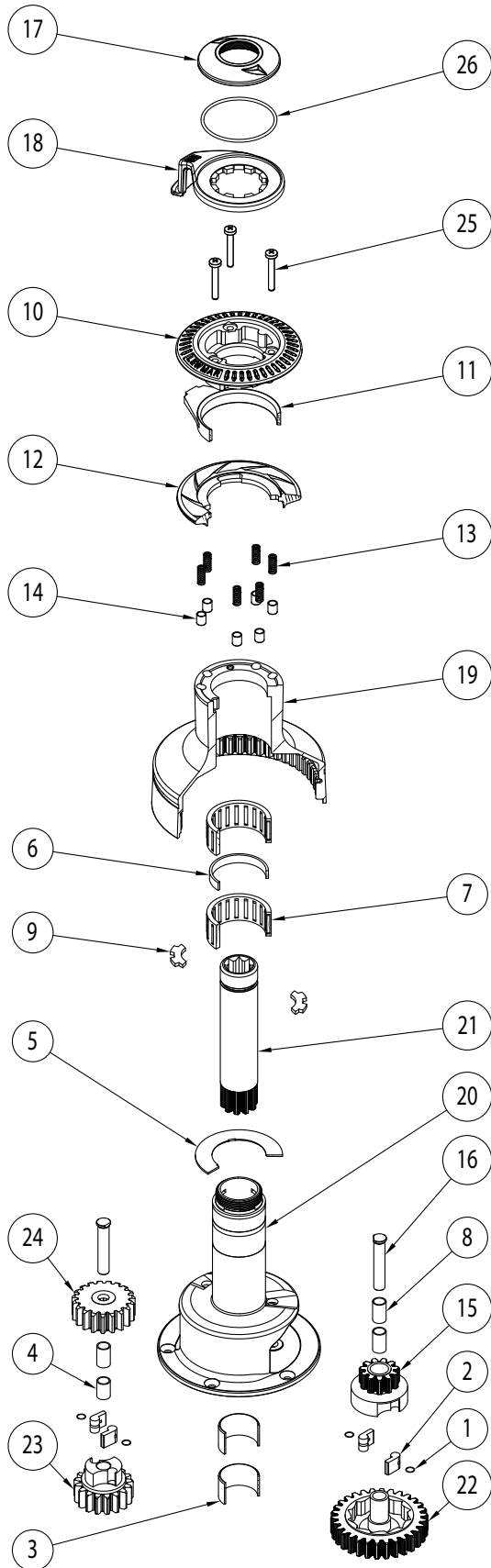

ITEM	PART NO	DESCRIPTION	QTY	KIT NO
1	1260/7	PAWL SPRING	4	48000019
2	1260/8	PAWL SMALL	4	48000019
3	15000377	BEARING SLEEVE	2	48000019
4	15000378	GEAR SPINDLE SLEEVE	1	48000467
5	15000466	DRUM WASHER	1	48000456
6	15000491	BEARING SPACER	1	48000456
7	15008007	NEEDLE BEARING	2	48000456
8	45000029	GEAR SPINDLE SLEEVE	3	48000464
9	45000102	COLLET	2	48000446
10	45000105	UPPER CROWN	1	48000449
11	45000108	STRIPPER RING	1	48000449
12	45000109	LOWER CROWN	1	48000449
13	45000112	SPRING	6	48000449
14	45000113	SPRING CUP	6	48000449
15	45000119	PAWL GEAR	1	48000464
16	45000123	GEAR SPINDLE	2	48300027
17	450001**	TOP CAP	1	CONTACT DEALER
18	45000203	FEEDER ARM	1	48000482
19	4500021*	DRUM	1	CONTACT DEALER
20	48040040	CENTRE STEM	1	48040040
21	45000218	MAIN SPINDLE	1	45000218
22	45000220	RATCHET GEAR	1	45000222
23	45000221	PAWL GEAR	1	48000467
24	45000222	RATCHET GEAR	1	48300029
25		PAN HEAD SCREW	3	48000449
26	B****	O RING	1	48000019

46ST Ocean Winch spares

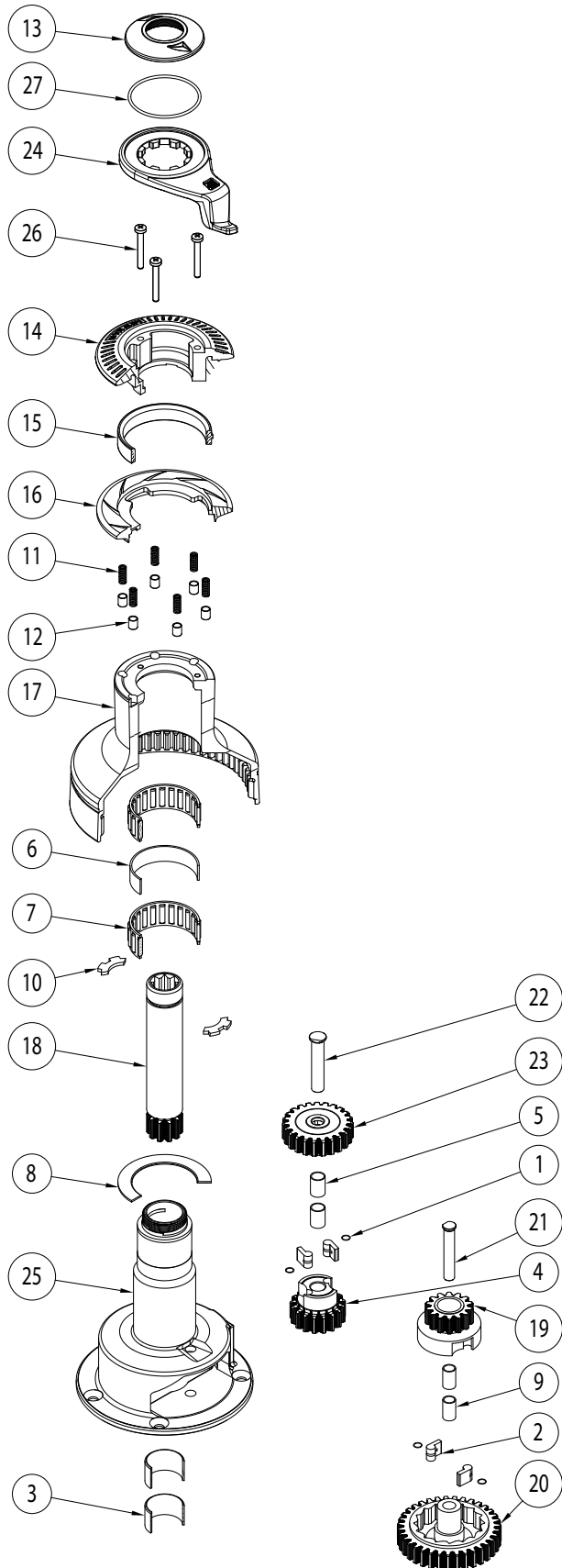

ITEM	PART NO	DESCRIPTION	QTY	KIT NO
1	1260/7	PAWL SPRING	4	48000019
2	1260/8	PAWL SMALL	4	48000019
3	15000377	BEARING SLEEVE	2	48000019
4	15000397	PAWL GEAR	1	48000468
5	15000398	SPINDLE SLEEVE	2	48000468
6	15000404	SPACER	1	48000457
7	15010007	ROLLER BEARING	2	48000457
8	15044116	DRUM WASHER	1	48000457
9	45000029	GEAR SPINDLE SLEEVE	2	48000469
10	45000102	COLLET	2	48000446
11	45000112	SPRING	6	48000450
12	45000113	SPRING CUP	6	48000450
13	450001**	TOP CAP	1	CONTACT DEALER
14	45000305	UPPER CROWN	1	48000450
15	45000308	STRIPPER RING	1	48000450
16	45000309	LOWER CROWN	1	48000450
17	4500031*	DRUM	1	CONTACT DEALER
18	45000318	MAIN SPINDLE	1	45000318
19	45000319	PAWL GEAR	1	48000469
20	45000320	RATCHET GEAR	1	48300036
21	45000323	GEAR SPINDLE	1	45000323
22	45000324	GEAR SPINDLE	1	45000324
23	45000333	RATCHET GEAR	1	45000333
24	45000355	FEEDER ARM	1	48000484
25	48046017	CENTRE STEM	1	48046017
26		PAN HEAD SCREW	3	48000450
27	B****	O RING	1	48000019



# 6. Winch

48ST Ocean Winch spares

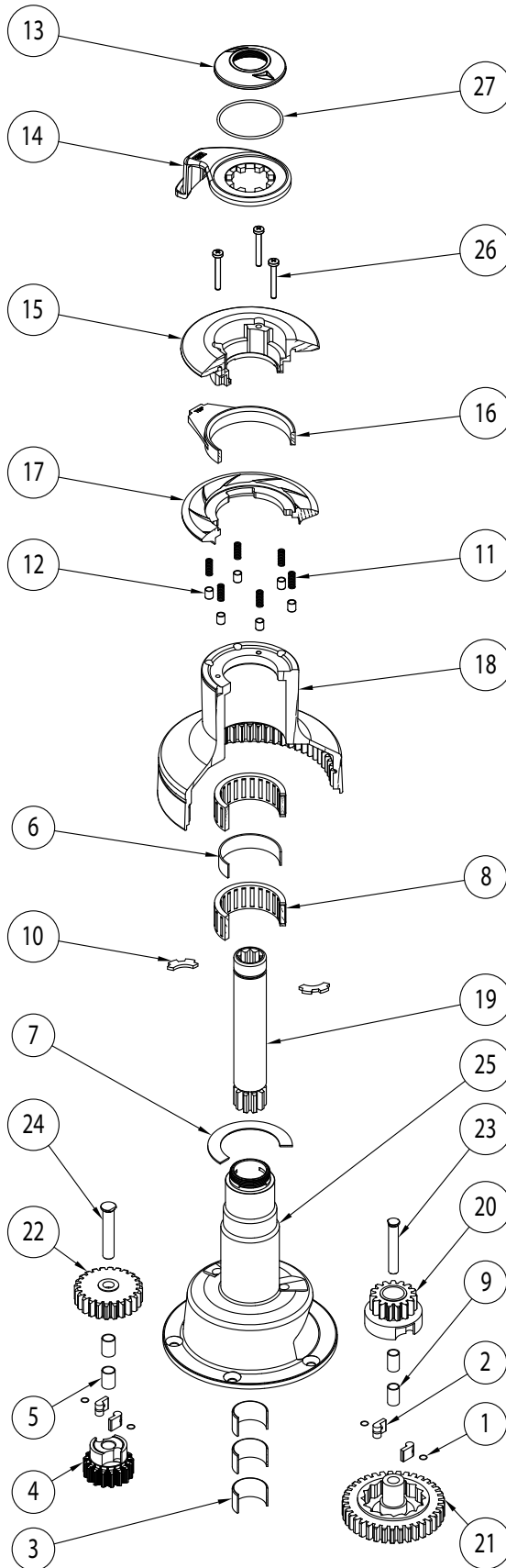

ITEM	PART NO	DESCRIPTION	QTY	KIT NO
1	1260/7	PAWL SPRING	4	48000019
2	1260/8	PAWL SMALL	4	48000019
3	15000377	BEARING SLEEVE	3	48000019
4	15000397	PAWL GEAR	1	48000468
5	15000398	SPINDLE SLEEVE	2	48000468
6	15000404	SPACER	1	48000458
7	15044116	DRUM WASHER	1	48000458
8	15044121	ROLLER BEARING	2	48000458
9	45000029	GEAR SPINDLE SLEEVE	2	48000470
10	45000102	COLLET	2	48000446
11	45000112	SPRING	6	48000451
12	45000113	SPRING CUP	6	48000451
13	450001**	TOP CAP	1	CONTACT DEALER
14	45000403	FEEDER ARM	1	48000485
15	45000405	UPPER CROWN	1	48000451
16	45000408	STRIPPER RING	1	48000451
17	45000409	LOWER CROWN	1	48000451
18	4500041*	DRUM	1	CONTACT DEALER
19	45000418	MAIN SPINDLE	1	45000418
20	45000419	PAWL GEAR	1	48000470
21	45000420	RATCHET GEAR	1	48300043
22	45000422	RATCHET GEAR	1	45000422
23	45000423	GEAR SPINDLE	1	45000423
24	45000424	GEAR SPINDLE	1	45000424
25	48048040	CENTRE STEM	1	48048040
26		PAN HEAD SCREW	3	48000451
27	B****	O RING	1	48000019



50ST Ocean Winch spares

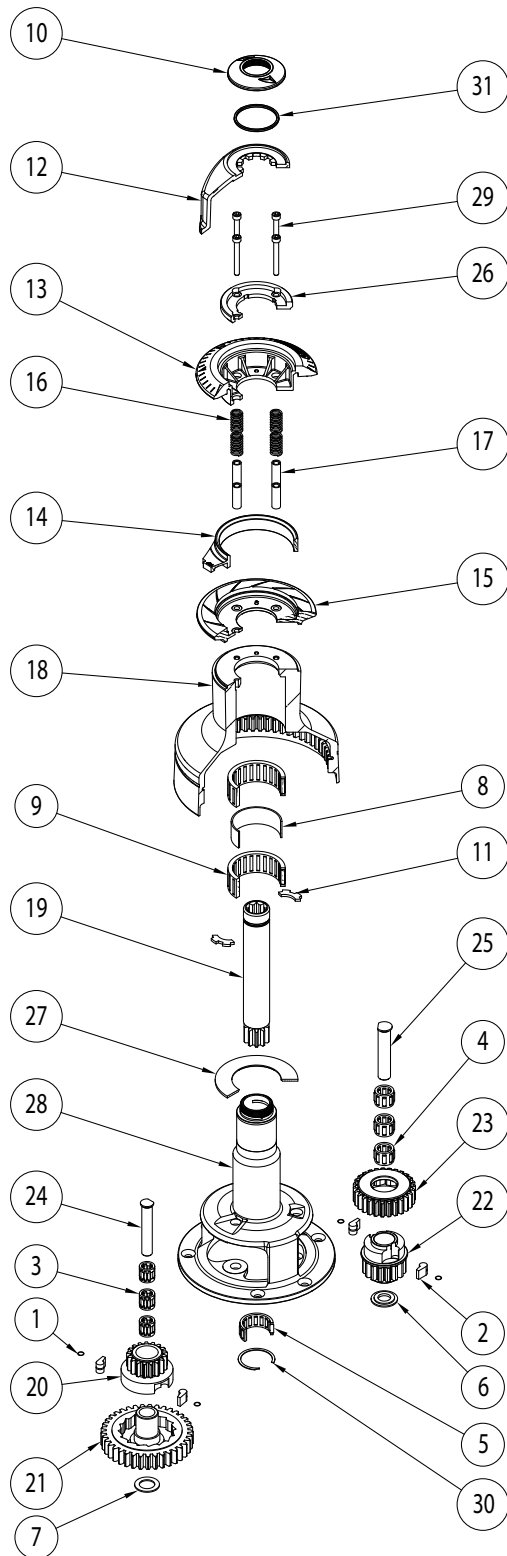

ITEM	PART NO	DESCRIPTION	QTY	KIT NO
1	1260/7	PAWL SPRING	4	48000017
2	1264/8	PAWL	4	48000017
3	1300/SA2	BEARING ASSY	3	48000017
4	15000017	ROLLER BEARING	3	48000473
5	15000019	ROLLER BEARING	1	48000019
6	15000646	WASHER	1	48000473
7	15000981	WASHER	1	48000017
8	15042012	SPACER	1	48000459
9	15044121	ROLLER BEARING	2	48000459
10	450001**	TOP CAP	1	CONTACT DEALER
11	45000102	COLLET	2	48000446
12	45000503	FEEDER ARM	1	48000486
13	45000505	UPPER CROWN	1	48000452
14	45000508	STRIPPER RING	1	48000452
15	45000509	LOWER CROWN	1	48000452
16	45000512	SPRING	4	48000452
17	45000513	SPACER	4	48000452
18	4500051*	DRUM	1	CONTACT DEALER
19	45000518	SPINDLE	1	45000518
20	45000519	PAWL GEAR	1	48000470
21	45000520	RATCHET GEAR	1	48300043
22	45000521	PAWL GEAR	1	48000473
23	45000522	RATCHET GEAR	1	45000422
24	45000523	GEAR SPINDLE	1	45000423
25	45000524	GEAR SPINDLE	1	45000424
26	48000452	SPRING RETAINER	1	45000525
27	45000534	DRUM WASHER	1	48000459
28	45000517	CENTRE STEM	1	45000517
29		SKT HD CAP SCREW M6 X 50	4	48000452
30	B2092	CIRCLIP	1	48000017
31	B****	O RING	1	48000055



# 6. Winch

54ST Ocean Winch spares

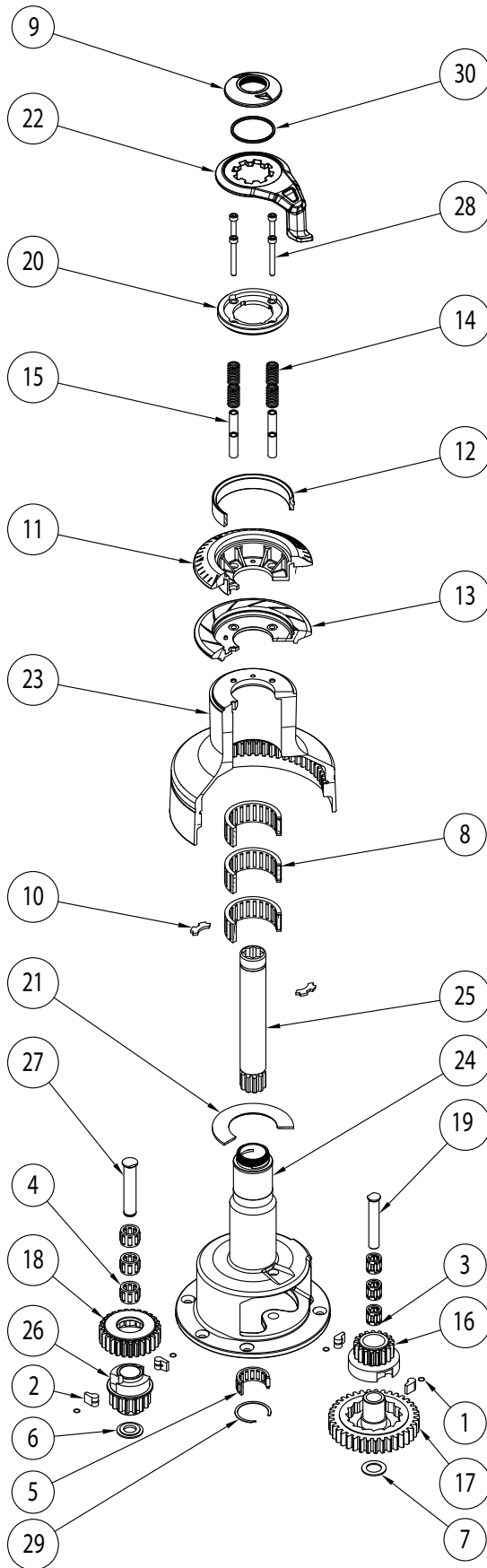

ITEM	PART NO	DESCRIPTION	QTY	KIT NO
1	1260/7	PAWL SPRING	4	48000017
2	1264/8	PAWL	4	48000017
3	1300/SA2	BEARING ASSY	3	48000017
4	15000017	ROLLER BEARING	3	48000473
5	15000019	ROLLER BEARING	1	48000019
6	15000646	WASHER	1	48000473
7	15000981	WASHER	1	48000017
8	15044121	ROLLER BEARING	3	4000460
9	450001**	TOP CAP	1	CONTACT DEALER
10	45000102	COLLET	2	48000446
11	45000505	UPPER CROWN	1	48000452
12	45000508	STRIPPER RING	1	48000452
13	45000509	LOWER CROWN	1	48000452
14	45000512	SPRING	4	48000452
15	45000513	SPACER	4	48000452
16	45000519	PAWL GEAR	1	48000472
17	45000520	RATCHET GEAR	1	45000520
18	45000522	RATCHET GEAR	1	45000522
19	45000523	GEAR SPINDLE	1	45000523
20	45000525	SPRING RETAINER	1	48000452
21	45000534	DRUM WASHER	1	4000460
22	45000603	FEEDER ARM	1	48000487
23	4500061*	DRUM	1	CONTACT DEALER
24	45000617SPA	CENTRE STEM	1	45000617SPA
25	45000618	SPINDLE	1	45500504
26	48000473	PAWL GEAR	1	45000621
27	45000624	GEAR SPINDLE	1	45000624
28		SKT HD CAP SCREW M6 X 50	4	48000452
29	B2092	CIRCLIP	1	48000017
30	B****	O RING	1	48000017

58ST Ocean Winch spares

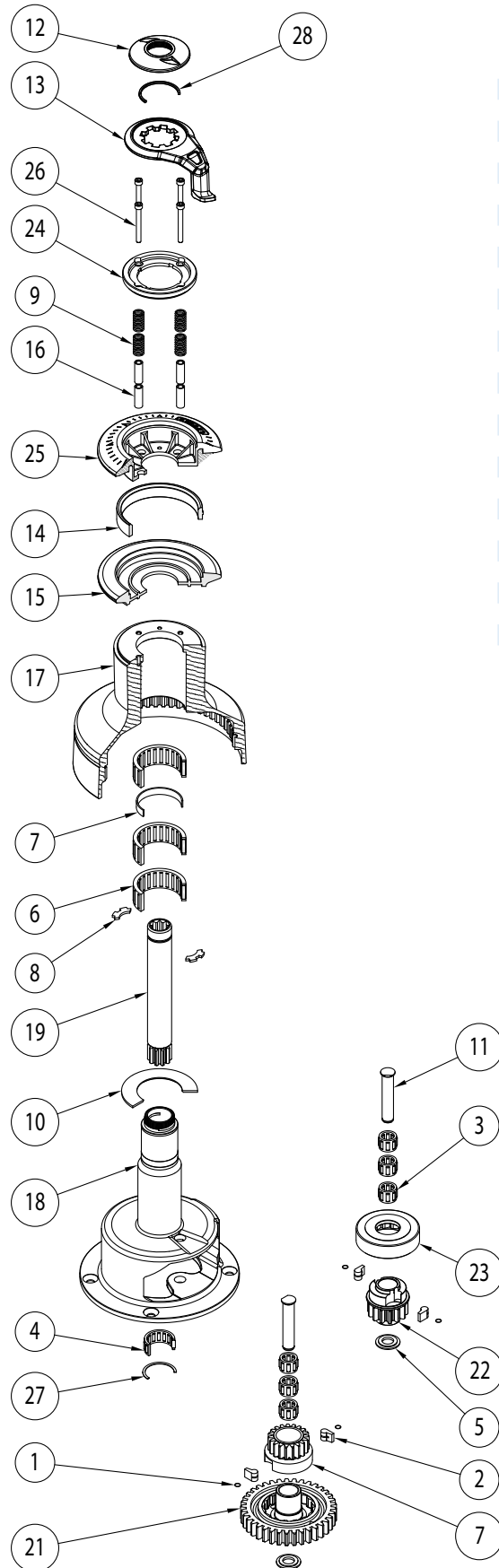

ITEM	PART NO	DESCRIPTION	QTY	KIT NO
1	1260/7	PAWL SPRING	4	48000017
2	1264/8	PAWL	4	48000017
3	15000017	ROLLER BEARING	6	48000017
4	15000019	ROLLER BEARING	1	48000019
5	15000646	WASHER	2	48000473
6	15044121	ROLLER BEARING	3	48000461
7	15065115	SPACER	1	48000461
8	45000102	COLLET	2	48000446
9	45000512	SPRING	4	48000453
10	45000534	WASHER	1	48000461
11	45000624	GEAR SPINDLE	2	45000523
12	450007**	TOP CAP	1	CONTACT DEALER
13	45000703	FEEDER ARM	1	48000488
14	45000708	STRIPPER RING	1	48000453
15	45000709	LOWER CROWN	1	48000453
16	45000713	SPACER	4	48000453
17	4500071*	DRUM	1	CONTACT DEALER
18	45000717	CENTRE STEM	1	45000717
19	45000718	SPINDLE	1	45000718
20	45000719	PAWL GEAR	1	48000472
21	45000720	RATCHET GEAR	1	45000520
22	45000721	PAWL GEAR	1	48000473
23	45000722	RATCHET GEAR	1	45000522
24	45000725	SPRING RETAINER	1	48000453
25	45000785	UPPER CROWN	1	48000453
26		SKT HD CAP SCREW M6 X 55	4	48000453
27	B2092	CIRCLIP	1	48000017
28	B****	O RING	1	48000017



# 6. Winch

65ST Ocean Winch spares

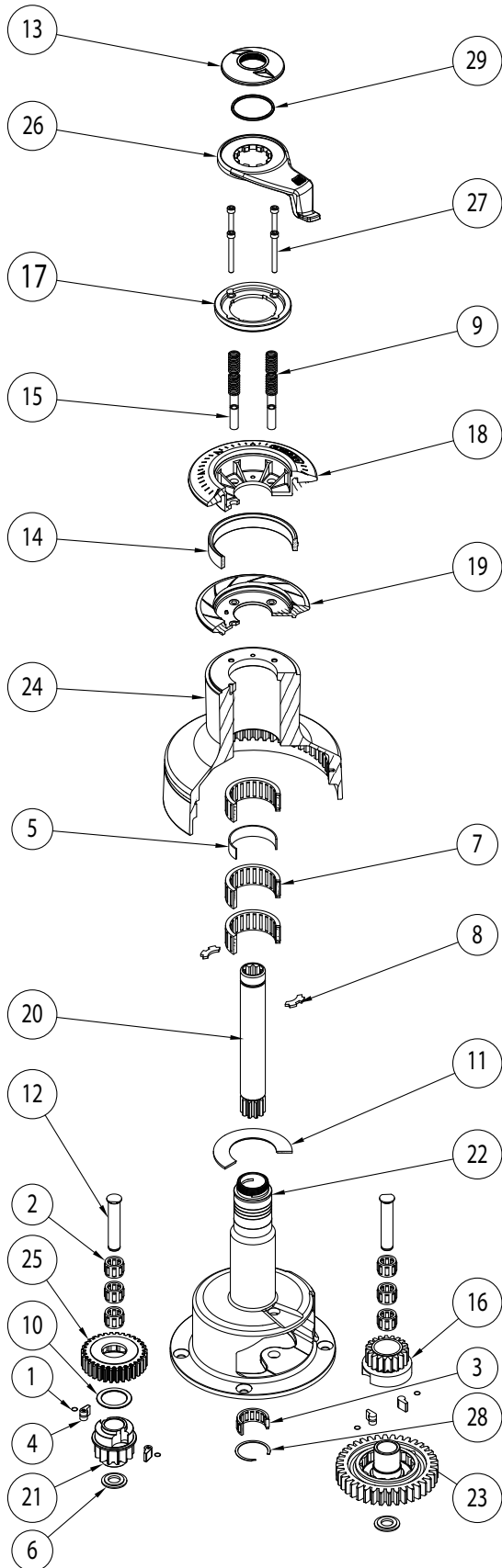

ITEM	PART NO	DESCRIPTION	QTY	KIT NO
1	1260_7	PAWL SPRING	4	48000017
2	15000017	ROLLER BEARING	6	48000017
3	15000019	ROLLER BEARING	1	48000017
4	15000301	SUPER PAWL LARGE	4	15000301
5	15000404	SPACER	1	48000462
6	15000646	WASHER	2	48000017
7	15044121	ROLLER BEARING	3	48000462
8	45000102	COLLET	2	48000446
9	45000512	SPRING	4	48500066
10	45000533	WASHER	1	48000476
11	45000534	DRUM WASHER	1	48000462
12	45000624	GEAR SPINDLE	2	45000624
13	450007**	TOP CAP	1	CONTACT DEALER
14	45000708	STRIPPER RING	1	48000453
15	45000713	SPACER	4	45000713
16	45000719	PAWL GEAR	1	48000475
17	45000725	TBD	1	48000453
18	45000785	UPPER CROWN	1	48000453
19	45000789	LOWER CROWN	1	48000453
20	45000818	MAIN SPINDLE	1	45000818
21	45000821	PAWL GEAR	1	48000476
22	45000850	CENTRE STEM 64ST	1	45000850
23	45000851	RATCHET GEAR	1	45000851
24	4500085*	DRUM	1	CONTACT DEALER
25	45005183	RATCHET GEAR	1	48000476
26	48000490	RATCHET GEAR	1	45005184
27	B0756	M6X55 SKT HD CAP SCREW	4	48000453
28	B2092	CIRCLIP	1	48000017
29	B6061	O_RING	1	48000017



## 7. Hydraulics

Since 1983, Lewmar has pioneered the use of hydraulic-powered sailing systems on yachts of all types. This has enabled larger vessels to be sailed with less crew more safely than ever before. A variety of heavy jobs can be completed at the touch of a button, making onboard life easier and more enjoyable.

## 7. Hydraulics

### Hydraulic Integrated Engineering Systems

A hydraulic power system can be engineered to perform many tasks, from hauling up the anchor to furling the sails. With over 30 years of experience, Lewmar can design a bespoke solution to suit your particular vessel.

With our range of power packs and control systems we can offer simple single function packs, to multi-function and multi-source systems for yachts up to 90m (300 ft).

Selection of the most suitable system will depend on a number of factors, but the following pages will provide valuable information which will enable owners, designers and builders to construct a working solution specifically to suit their requirements.

For more details please contact [custom@lewmar.com](mailto:custom@lewmar.com)





**1 Mast or Boom Furler**

Lewmar have a hydraulic system that can control any of the world's furler manufacturer's units.

**2 Transom Door and Passarelle**

Lewmar can provide control systems for different actuator methods, whether they are cylinders or rotary actuators, balanced, or unbalanced systems.

**3a Deck Winches**

Sail handling winches whether conventional or self-tailing.

**3b Captive Winches**

Powered Line Management System below deck.

**4 PTO Pump**

Pumps fitted to either main engine or generator, or both. Primarily to power thrusters but also to power all hydraulic systems.

**5 Commander Hydraulic Power Pack**

A variety of power packs are available. Single/Multiple motor, various voltages, custom reservoirs, the list is endless.

**6 Bow Thrusters**

Lewmar offer a wide range of thrusters (See Thruster section for details). The thruster can be powered from main engine or generator.

**7 Anchor Windlass**

The Lewmar anchor windlass is an ideal addition to the system, and offers an excellent level of performance.

**8 Headsail Furlers**

Hydraulic headsail furlers from various manufacturers are a stylish and reliable way to control the size of the headsail. Valves and control systems are available for headsails.

**9 Rig Control**

The sail handling system can be also integrated with rig control cylinders such as back stay and boom vang for rapid take-up facility.

## 7. Hydraulics



### Vortex Reservoir

The patent pending Vortex Hydraulic Reservoir actively removes air from a vessel's hydraulic system during any hydraulic product operation using the internally created spiralling, high-speed vortex. As only a small amount of air remains entrapped in the oil, a smaller oil reserve is required - up to 95% less stored oil is required with a Vortex Reservoir. With minimal air in the system, hydraulic motor performance is improved by 20%.

The unique internal flow pattern, created where the returned oil enters the reservoir, removes both free and dissolved air within the hydraulic system. Once the system is installed and bled, no air can be reintroduced into the system, therefore giving a higher performance between oil changes.

The bellows allow for thermal expansion of the system and act as an oil reserve when cylinders are used. The small space envelope required for 'Vortex' means it will fit into boats as small as 40ft.

- Reservoir weight reduction of 63% - 93%
- Huge reductions of up to 93% of required oil volume
- Smaller pump and suction lines can be used, significantly reducing installed system weight
- Higher system efficiency leads to increased hydraulic motor performance of up to 20%
- Stronger sheet winch and windlass pulls, and more powerful thrust can be achieved
- Superior pump protection with the removal of entrapped air
- Closed systems means no chance of air and oil mixing once the system is primed and commissioned



NOMINATED  
**DAME** DESIGN  
AWARD





### Weight Saving

Weight reduction is a key element in all modern boat design - power and sail - as such, removing excess quantities of heavy stored oil is an efficient way to save weight. The storage tank is only used to cool oil within the system and reduce cavitation. Using Lewmar's Vortex can reduce the hydraulic powerpack weight by as much as 93% while improving running efficiency.

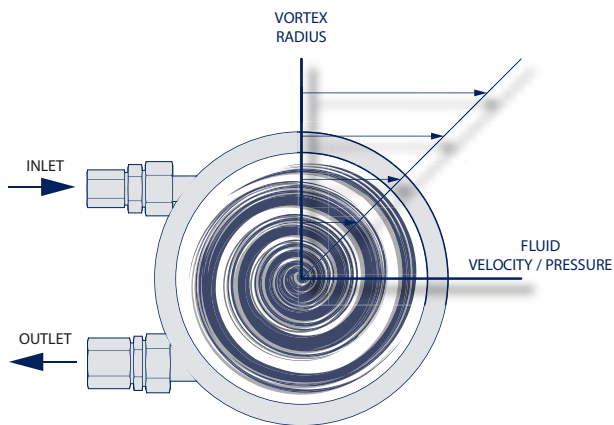

**93%**

TYPICAL OIL VOLUME AND WEIGHT SAVING ON 100' (30m) SAILBOAT

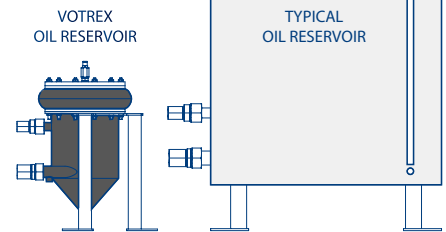

Typical Weight for Reservoir and Hydraulic Oil

	60FT	90FT	120FT	150
TYPICAL RESERVOIR AND OIL	35KG	244KG	431KG	508KG
VORTEX RESERVOIR AND OIL	13KG	16KG	32KG	36KG
% WEIGHT REDUCTION	63%	93%	92%	93%

The evolution of global superyacht regattas has moved the superyacht sailboat market from a predominantly cruising market to high-performance designs. The revolutionary Vortex powerpack design significantly reduces the amount of air within the oil. Usual systems run at 12% air in the oil, but the Vortex design can reduce this to less than 3% - leading to increased efficiency in the pulls of sheet winches, vital in race situations.

**20% INCREASED POWER**  
FOR SAILBOAT WINCHES, WINDLASS AND POWERBOAT THRUSTERS

**50% REDUCTION IN**

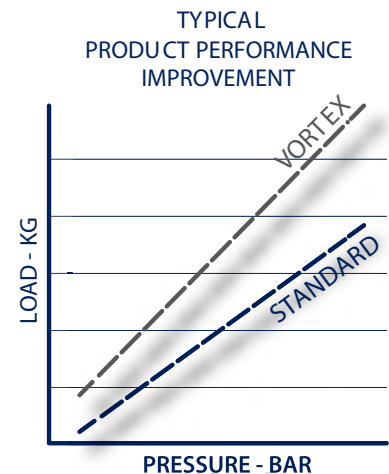

## 7. Hydraulics



### Lewmar Hydraulic Cylinders

Lewmar now offer a range of hydraulic cylinders specifically designed and optimised for marine use. Available in black anodized Aluminium or full Stainless Steel our cylinders can be single or double-acting. Choose from a range of standard cylinders or specify a custom stroke to suit your application.

Designed and built in our UK factory, end fittings and attachments can be tailor made to suit your installation and to match the full range of Lewmar hardware.

- Stroke length to 2800mm
- -10 to -90 as standard
- Custom larger cylinders on request
- Custom mounting
- Integrated ends
- Position indicating option
- Locking option





## Hydraulic Integrated Engineering Systems

Four main assemblies need to be carefully considered to enable the system to be correctly specified.

- **Power pack** suitably sized to match hydraulic functions such as winches, windlasses, furlers, cylinder etc.
- **Directional control valve** stations, these can be on one manifold block with one to six valves, or in any combination of manifolds and valves. A range of valve assemblies are available to suit operating requirement of hydraulic functions.
- **Control System** is a bespoke control system with customised operator interface and helm controls, with additional optional extras such as stainless steel mounting panel.
- **Return line oil filter** maintains a good level of oil cleanliness which is essential to the performance and reliability to the hydraulic system.



### Panels

Control panels designed and manufactured in a variety of weather resistant materials and components provide overall system and individual function control, from a helm station or other location as desired.

Features multicoloured indicating push buttons and switching or proportional joysticks for control of thrusters, captive winches and sail furling systems.

### PowerPack

When a system has more than one electric motor-pump, the control system will tailor the operation of each motor to start and stop individually or in conjunction in order to meet the hydraulic requirements efficiently and to reduce motor wear and strain on the power supply. All motors are thermally monitored and made safe in case of overheating. Both AC & DC motors can be provided with an option with variable speed control giving soft starting and idle speed control to improve response times, further reducing wear.

### PTO Pump Control

The control system can monitor the main engine speed or a generator status to engage a pump on the PTO when power is available and automatically disengage to reduce wear and power wastage.



# 7. Hydraulics



## Commander 200 & 200HP

The concept of the Commander system is flexibility, its modular ordering format allows the required specification to be suited to each vessel as necessary.

The Commander 200 is a compact hydraulic power unit capable of operating winches, anchor windlasses, furling systems and auxiliary functions one at a time. Both 12 and 24 volt versions feature a fan cooled electric motor, offering high pressure and flow performance coupled to a long duration running time, together with thermal protection safety switches.

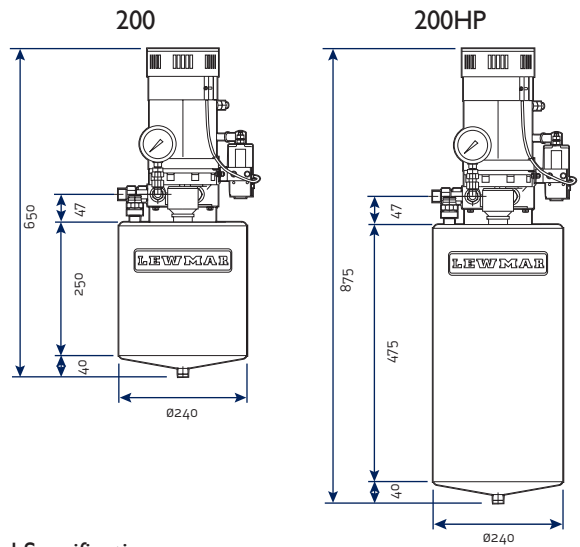

### Hydraulic Specification

	200	200 HI-PRESSURE
OPERATING PRESSURE	140 BAR (2030 P.S.I.)	230 BAR (3300 P.S.I.)
MAX FLOW	16L/MIN (4.3 US GAL)	9L/MIN (2.3 US GAL)
RESERVOIR CAPACITY	9 LITRES (2.4 US GAL)	19.5 LITRES (5.2 US GAL)
HYDRAULIC OIL TYPE	ISO VISCOSITY GRADE 32	ISO VISCOSITY GRADE 32

### Electrical Specification

12 and 24 Volt motors nominally rated to 3kW.

Supply voltage limits,  $\pm 15\%$

At extreme tolerances the unit will operate with de-rated performance.

Small and large tank capacity versions available - contact [custom@lewmar.com](mailto:custom@lewmar.com) for details

### Performance Characteristics – Commander 200

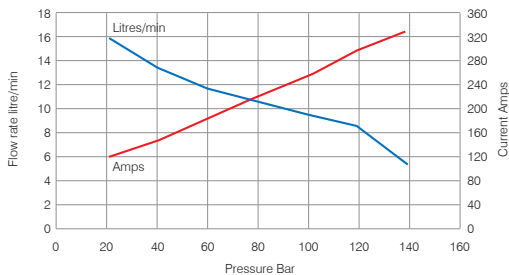

12V

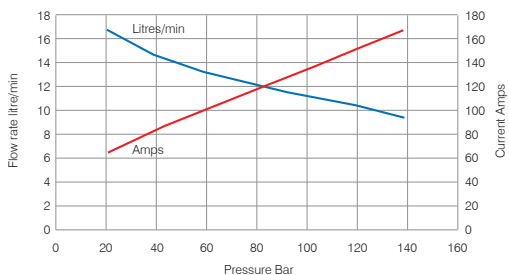

24V

### Performance Characteristics – Commander 200HP

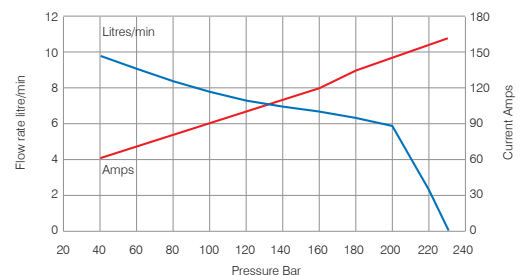
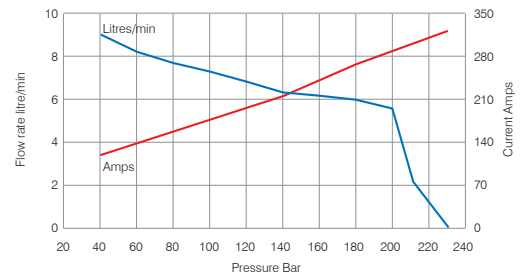



## Commander 400

The Commander 400 continues the flexibility of the Commander 200 but with increased power. It is available in 12 or 24 volt versions, both are fan cooled. The Commander 400 is ideal for vessels which require high flow for sailing functions.

Variations of this Commander using high pressure (230 bar/3250 psi) motor-pumps are available, typically suitable for cylinder sheeting applications.

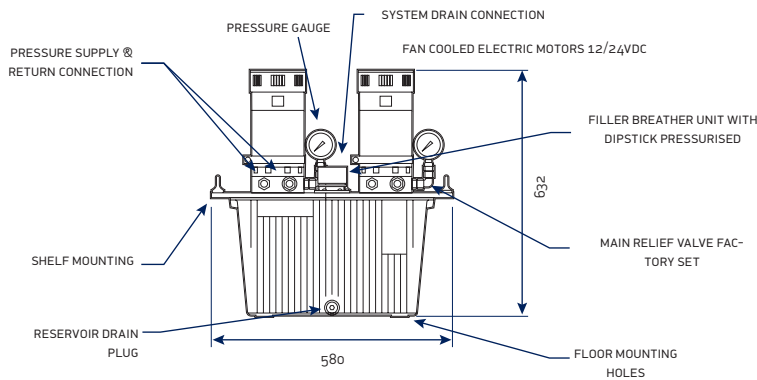

### Hydraulic Technical Specification – Commander 400

OPERATING PRESSURE	140 BAR (2030 P.S.I.)
MAX FLOW	32L/MIN (8.4 US GAL)
RESERVOIR CAPACITY	27 LITRES (7.1 US GAL)
HYDRAULIC OIL TYPE	ISO VISCOSITY GRADE 32

### Electrical Specification

12 and 24 volt motors nominally rated to 3kW and fan cooled.

Supply voltage limits,  $\pm 15\%$

At extreme tolerances the unit will operate with de-rated performance.

### Performance Characteristics – Commander 400 12V

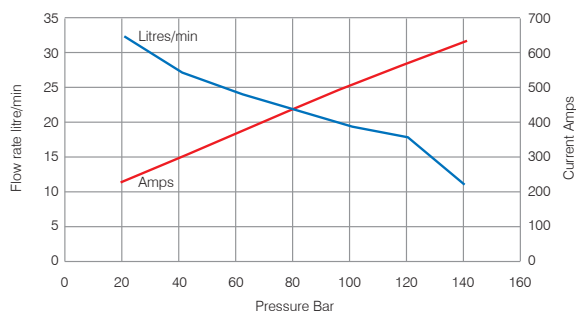

### Performance Characteristics – Commander 400 24V

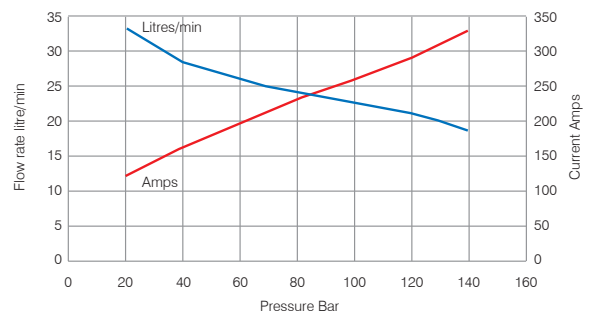

Commander 400HP also available. Contact your Lewmar representative for more information.

# 7. Hydraulics



## Commander 600

The Commander 600 is an increased step up from the Commander 400, where the addition of a third motor-pump which provides greater flexibility in multifunction use.

For example, tacking/gybing where hydraulic furlers are used in conjunction with winches.

12V DC version and custom tank designs available on request.

Variations of this Commander using high pressure (230 bar/3250 psi) motor-pumps are available, typically suitable for cylinder sheeting applications.

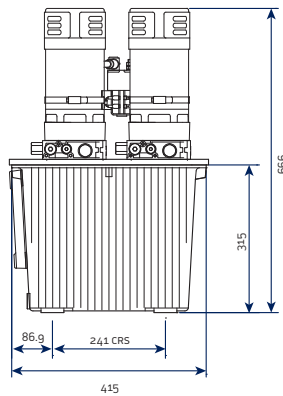
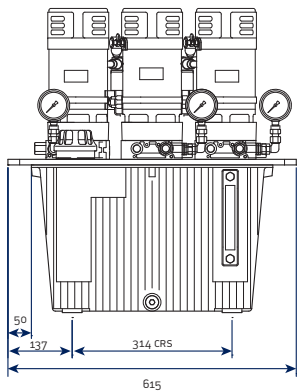

### Hydraulic Technical Specification – Commander 600

OPERATING PRESSURE	140 BAR (2030 P.S.I.)
MAX FLOW	48L/MIN (12.7 US GAL)
RESERVOIR CAPACITY	40 LITRES (10.6 US GAL)
HYDRAULIC OIL TYPE	ISO VISCOSITY GRADE 32

### Electrical Specification

12 and 24 volt motors nominally rated to 3kW and fan cooled.

Supply voltage limits,  $\pm 15\%$

At extreme tolerances the unit will operate with de-rated performance.

### Performance Characteristics – Commander 600 24V

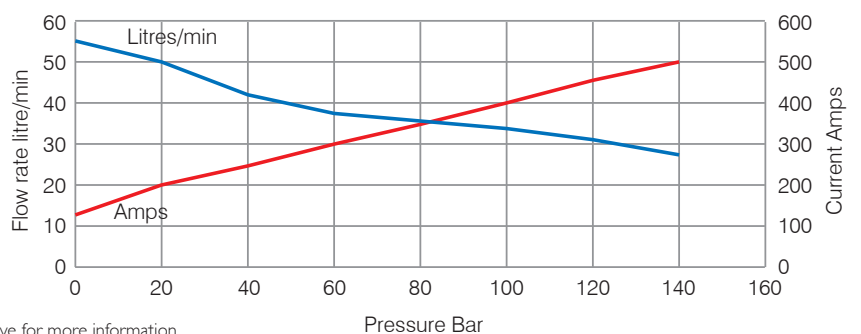

Commander 600HP also available. Contact your Lewmar representative for more information.



## Custom Commander Systems

The Lewmar range of Custom Commanders is very comprehensive. This type of system allows the design of a fully integrated hydraulic package to be installed and ensures the builder has a fully engineered package. Custom commander systems can be fully integrated with Lewmar Thrusters powered by PTO Pumps. This allows the use of a single reservoir, saving valuable space.

It also allows the use of the Thruster pump to act as an additional power source for the sailing system hydraulics. This can offer considerable benefits in the reduction of battery charging and provide a more efficient power source. Lewmar Custom Commander Systems have been used on over 200 yachts in the last 15 years, a testament to the popularity, and reliability of the product.

- DC motors from 3–15 kW
- Multi motor combinations
- 3 phase AC versions up to 15kW
- AC/DC versions
- Custom designed reservoirs
- Remote valve groups
- Proportional control
- PLC control
- Enclosure HMI showing alarms and operating conditions
- Field bus control
- Electric soft start / speed control
- Various alarm outputs
- Fan cooled motors
- Thermal overload protection
- Custom program design
- Supported by Lewmar for the lifespan of the system
- Modbus interface



## Custom Power Packs & Reservoirs



- Reservoir sized to match the requirements of the hydraulic system to store and condition the oil while shaped to fit into the space available in the yacht.
- Multiple electric motor pump sets can be mounted onto the reservoir to provide a compact power solution using various sizes of AC or DC motor pump units to match the power requirements of the hydraulic system in the most efficient way.
- Bulkhead or Foot mounted reservoirs are available for PTO or stand alone pump only hydraulic systems.

# 7. Hydraulics

## Pump Drives

The real art of achieving an integrated system installation that is efficient and trouble-free is the design of the pump drive system. Lewmar have hundreds of designs that have been giving reliable service for years.

The design of such a system is a very careful balance between the performance characteristics of the power source (main engine, gearbox or generator), choice of thruster drive motor, and set up of the control system.

Lewmar specify variable displacement pump and fixed displacement pump drive systems dependant on system requirements.

These systems offer fingertip control of power selection, are extremely energy efficient as you only generate the power demanded and generate less noise. The various types of drive offer different benefits, but all depend on correct engineering.

A range of modular valve solutions are available to tailor the hydraulic power for precise control of any individual hydraulic function



### Main Engine Pump Drive - PTO (Power Take Off)

Careful consultation between Lewmar and the engine manufacturer will assure a pump drive that will give a good spread of power from idle to higher RPM. Obviously some engines are better suited than others but most of the higher torque models will offer good results. Lewmar recommend the fitment of an electromagnetic clutch in order that the pump can be disconnected when not required. This saves energy, heat and noise. A speed trip can also be fitted to ensure that the engine is not stalled at low RPM, or the pump is not damaged at high RPM.

## Gearbox Drive

Some gearbox manufacturers can provide a PTO output if specified. Some are clutched and some are direct coupled. Again, with careful consultation we can provide a pump drive to suit. Even without a clutch we can provide a speed sensor that will allow the pump to run at standby if the RPM are too low or too high.

## Generator Drive

If the generator can provide sufficient usable power, this is an excellent way of achieving thrust without disturbing the main engine. The major generator manufacturers can provide a clutched PTO output if specified. Lewmar can then match a pump to suit. The advantage of this system is that the generator runs at a constant high RPM, so the pump size can be smaller for the same horsepower. No speed trip is required, as the RPM is constant.

- Simple on-off or fully proportional control is available
- Valves can control pressure ranges up to 350 bar (5000 psi)
- In the case of specialist hydraulic functions a custom designed valve manifold can be supplied.

## Valves







### Control System

A control system is required for the correct and safe operation of the hydraulic system. It is used to make sure that when a deck switch or joystick is pushed, the right amount of hydraulic power is supplied to the hydraulic function from the correct power source.

The control system design is tailored to the needs of the customer and the requirements of the hydraulic system. Depending on complexity, the package can range from a barebone system as available with the Commander 200/400 to a PLC (Programmable Logic Controller) system, with the option to extend to a FieldBus control network for comprehensive control and automation.

### Oil Status

The control system monitors the system oil levels, filtration and temperature providing user feedback with audible alarms and indicators and will disable the system should the oil level reach minimum to prevent damage.

### PLC Control

Programmable controller, extremely robust and reliable, simple to install. Every PLC system custom designed to match the complexity and needs of the hydraulic system.

- Easy to troubleshoot using built in input & output indicators
- Each PLC is individually programmed & tested. Lewmar keeps a copy of the program for ongoing support purposes

### Remote Access and Upgrades

Display screen showing up to date information, any faults and fault history, along with an event log. The screen aids in troubleshooting any problems that may occur with ease. Remote access allows Lewmar to update programs accordingly.

### PLC Field Bus

This is a more advanced PLC control system which controls the hydraulics using an ASi (Actuator Sensor Interface) network. This is a simple, robust and reliable network which distributes control of the hydraulic system throughout the yacht using simple wiring and IP65 connection modules making it a perfect match for the environment.



# 7. Hydraulics

## Case Study

A typical hydraulic system which can be found on a 60-70ft yacht featuring a custom-designed Commander 400 and a pump from a generator-clutched PTO output. The PTO pump is sized to match the thruster and powers the thruster only in docking mode while the Commander powers the rest of the system. However, when sailing the PTO pump will power all non thruster functions leaving the Commander as backup and for night/quiet operation.

The control system is designed to use a barebones Commander 3/8 control box and a custom stainless control panel with a proportional paddle joystick giving fine thruster control.

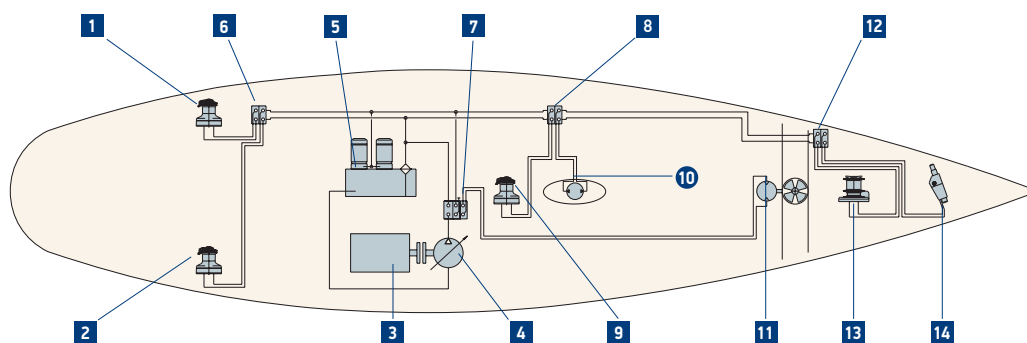

18m (60ft) Typical Hydraulic Schematic

POSITION	DESCRIPTION	TYPE	PRESSURE FLOW
1	PRIMARY WINCH	LEWMAR 70/3	140 BAR – 20 L/MIN
2	PRIMARY WINCH	LEWMAR 70/3	140 BAR – 20 L/MIN
3	GENERATOR SET WITH CLUTCHED PTO	VARIOUS	
4	VARIABLE DISPLACEMENT PUMP	41 CC/REV	210 BAR – 53 L/MIN
5	24 V DC HYDRAULIC POWER PACK	CUSTOM COMMANDER 400	140 BAR – 30 L/MIN
6	AFT WINCH VALVE GROUP	2 STATION VALVE GROUP	
7	PTO BACKUP/THRUSTER VALVE	2 STATION VALVE GROUP	190 BAR – 53 L/MIN 140 BAR – 30 L/MIN
8	MAST WINCH/FURLER VALVE GROUP	2 STATION VALVE GROUP	
9	HALYARD/OUTHAUL WINCH	LEWMAR 55SHST	140 BAR – 20 L/MIN
10	IN MAST MAIN FURLER	VARIOUS	140 BAR – 20 L/MIN
11	15HP TUNNEL THRUSTER	LEWMAR 250TTH	190 BAR – 53 L/MIN
12	FWD WINDLASS/FURLER VALVE GROUP	2 STATION VALVE GROUP	
13	GYPSY CAPSTAN ANCHOR WINDLASS	LEWMAR V6	140 BAR – 30 L/MIN
14	HEADSAIL FURLER	VARIOUS	140 BAR – 15 L/MIN



## 8. Hardware

From the plain bearing Synchro range to our High Load Racing blocks, machined from solid-billet aluminium, every Lewmar product benefits from our many years of experience in both cruising and racing boats. The range has evolved to offer solutions from a small 20ft cruising or racing boat up to some of the world's leading superyachts.

# 8. Hardware

## Lewmar Block Range



### Page 291 Control Blocks – Control lines & hand loads

- Long glass-fibre reinforced composite cheeks
- Stainless steel ball bearings



### Page 296 Synchro Cruising blocks

- Stainless steel straps and glass-fibre reinforced cheeks
- Easy to use, patented shackle post lock
- High density, free-spin plain bearing
- Sheave / bearing / pin & line size optimised for efficiency



### Page 301 HTX Range – Racing and Cruising Blocks

- Alloy cheeks
- Side thrust ball bearings
- High load capacities
- Head design inspired by racing blocks
- Stainless Steel Range Available



### Page 305 Racing Range

- Monocoque alloy construction
- Light weight - High strength to weight ratio
- Ball and roller bearings
- High level of type optimisation – webbing, runner, Halyard blocks etc



### Page 314 Special Application Blocks

- Snatch Blocks
- Loop Blocks
- Pivoting Lead Blocks



### Page 317 Custom Hardware for Superyacht Projects

- Performance hardware suitable for high loads generated on superyachts
- Customised to blend with overall design aesthetic
- Designed to meet individual functional specification



### Page 318 Soft Loop Blocks

- Lightweight, ultra-tough continuous loop blocks
- Designed for high-performance sailing

Note: Lewmar blocks are intended for sail control line handling on sail boats only. Buyers intending to use them for any other purpose should seek independent professional advice as to their suitability. Lewmar accepts no liability arising from such other uses.



## Technical Reference – Choosing the right purchase system

Lewmar manufactures a diverse range of blocks to suit all marine applications. This guide aims to help you to choose the best purchase system and the appropriate Lewmar products to suit your application.

### Why do we need purchase systems?

As a guide, the average person can:

- Pull vertically down a force equivalent to their body weight (for a short period)
- Adjust control lines frequently loaded to 25kg
- When fully braced, pull intermittently sideways with one hand to 25kg and with two hands to 50kg
- Exert 15kg single-handed and 25kg double-handed on a winch handle

Human force can be multiplied through a purchase system made up of block systems and/or winches, enabling comfortable operation of high-loaded sailboat controls.

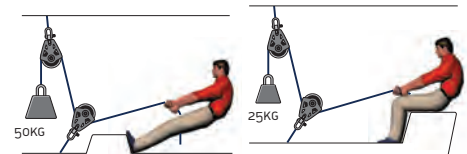
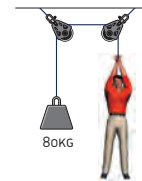

### Which purchase system?

#### Multi-Purchase System

- Ideal for mainsheet traveller systems
- Provides full range of adjustment

#### Cascade System

- Ideal for a vang, backstay or outhaul
- Achieves a smaller range of adjustment
- Provides high purchase with minimum blocks
- Line type and diameter can be specified in line with load on each part of system
- Enables control lines to be led to either side of the boat, for example, with a backstay adjuster
- All blocks must be free to travel their full working length without danger of catching

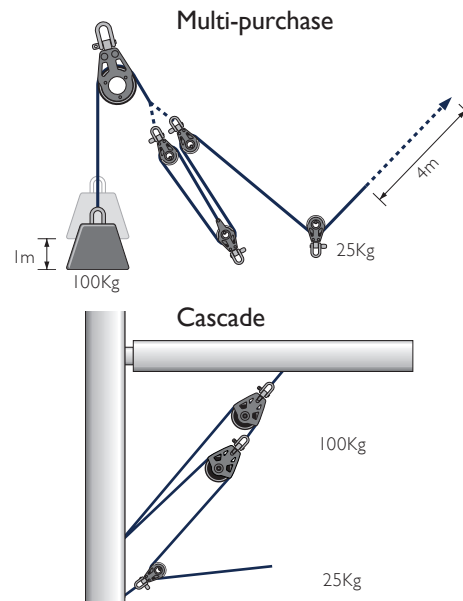

### Some typical systems in use on current boats

	BACKSTAY	MAINSHEET TRAVELLER	MAINSHEET COARSE TUNE	EXTRA PURCHASE FOR MAINSHEET FINE TUNE	JIB TRAVELLER	VANG	CUNNINGHAM
RACING DAYBOAT	16:1 CASCADE	2:1	2:1	4:1 MULTI-PURCHASE	PLUNGER	8:1 COMBINATION	4:1 CASCADE
SMALL CRUISER	FIXED	2:1	4:1 MULTI-PURCHASE	-	PLUNGER	4:1 MULTI-PURCHASE	N/A
SMALL RACING YACHT	16:1 COMBINATION	8:1 MULTI-PURCHASE	6:1 MULTI-PURCHASE	4:1 MULTI-PURCHASE	8:1 COMBINATION	20:1 COMBINATION	4:1 CASCADE
MEDIUM CRUISER	FIXED	4:1	4:1	N/A	2:1 WITH PLUNGER	5:1	N/A
MEDIUM RACING YACHT	HYDRAULIC	12:1 COMBINATION	2:1 WINCHED	N/A	12:1 COMBINATION	36:1 COMBINATION	6:1 COMBINATION
LARGE CRUISER	HYDRAULIC	6:1	4:1 WINCHED	N/A	2:1 WITH PLUNGERS	8:1	4:1
LARGE RACING YACHT	HYDRAULIC	2:1 WINCHED	2:1 WINCHED	N/A	2:1 WINCHED	HYDRAULIC	6:1 COMBINATION

# 8. Hardware

## Combination Cascade/Multi-Purpose System

- Achieves compromise between power and range requirements
- Ideal for use on backstay, jib, and mainsheet controls

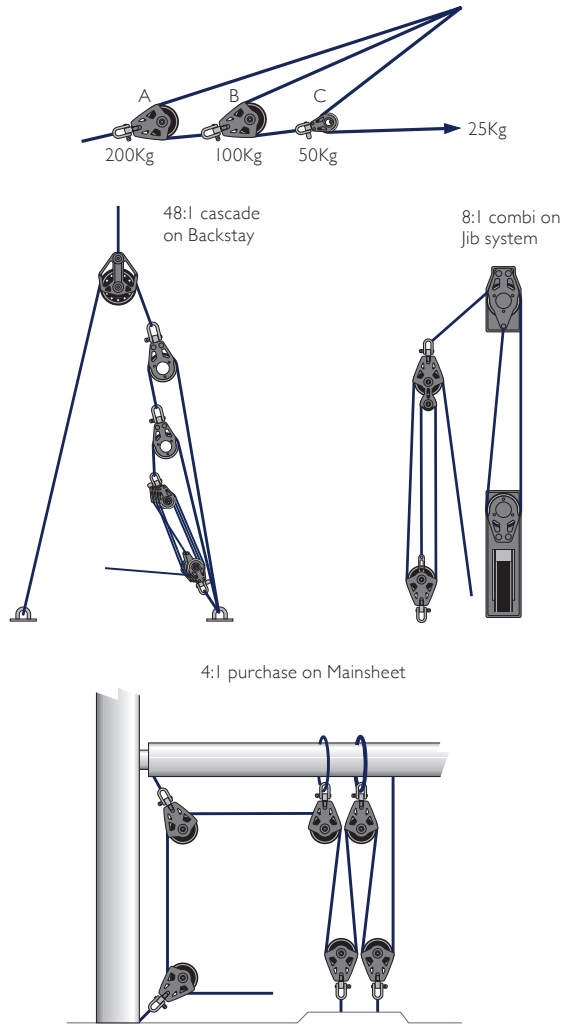

## Coarse/Fine Tune System

- Coarse purchase ideal for racing mainsheet systems
- Used for moving large amounts of unloaded mainsheet during mark rounding
- Combination fine purchase perfect for playing the mainsheet when beating

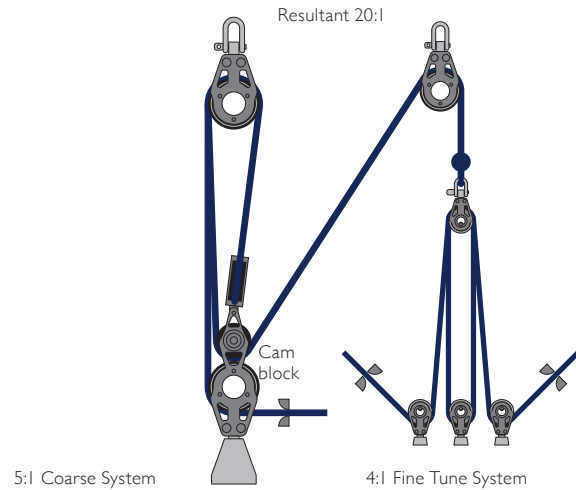

## Reverse Purchase

- Ideal for an asymmetric pole launch system
- Offers fast movement and a greater range on lightly-loaded systems
- Cleat is located on control line, which is loaded to twice the pole launch rope

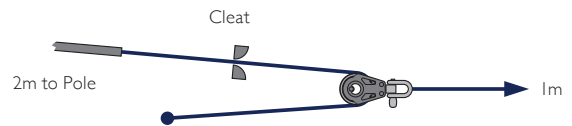

## How much purchase power is needed?

To identify the amount of purchase power required, carry out the following calculation:

$$\frac{\text{Output Force}}{\text{Input from Control Line/Winch}} = \text{Purchase Required} \quad \frac{200\text{kg}}{25\text{kg}} = 8:1$$

The table gives some examples of typical purchases used by Lewmar customers.

## Typical purchase systems

BOAT SIZE	4M/13FT	6M/20FT	8M/26FT	10M/33FT	12M/39FT	14M/45FT	16M/53FT
MAINSHEET – HAND	3:1	4:1	4:1	5:1-10:1	8:1-24:1	-	-
MAINSHEET – WINCHED	-	-	-	3:1	4:1	4:1	4:1
VANG – CRUISING	4:1	4:1	4:1	6:1	8:1	10:1	10:1
VANG RACING	5:1	6:1	8:1	12:1	24:1	36:1	48:1
CAR TOW – CRUISING	-	-	2:1	2:1	2:1	3:1	3:1
CAR TOW – RACING	-	2:1	3:1	6:1	10:1	2:1 (WINCH)	2:1 (WINCH)

## Winched purchases

To identify the amount of purchase power required in winched purchase, first calculate the winch output:

$$\text{Winch Model Number} \times \begin{matrix} 15\text{kg (single-handed operation)} \\ 25\text{kg (double-handed operation)} \end{matrix} = \begin{matrix} \text{Winch} \\ \text{Output} \end{matrix}$$

$$\frac{\text{Output Force}}{\text{Winch Output}} = \text{Purchase Required}$$

The table suggests the pulling power that can be generated.

## Typical winch output loads

WINCH SIZE	30	40	45	50	55
ONE HANDED INPUT – 15 KG ON HANDLE = WINCH OUTPUT LOAD	450KG	600KG	660KG	720KG	-
TWO HANDED INPUT – 25 KG ON HANDLE = WINCH OUTPUT LOAD	-	-	1100KG	1200KG	1350KG

## Which Bearing?

APPLICATION	BEARING	RECOMMENDED LEWMAR RANGE
FREQUENTLY ADJUSTED, FREE, FAST-RUNNING SYSTEMS SUCH AS SHEETS OR CONTROL LINES	BALL BEARING SHEAVE	CONTROL BLOCK
HIGH-STATIC LOADINGS, ADJUSTED LESS FREQUENTLY AND MAINLY CLEATED, SUCH AS HALYARDS	FREE SPIN BEARING	SYNCHRO BLOCK
FREQUENTLY ADJUSTED, HIGH LOADED SYSTEMS, USING MODERN LINE TECHNOLOGY WITH HIGH LOAD ON REDUCED LINE DIAMETERS.	FREE SPIN BEARING WITH BALL BEARING SIDE THRUST.	HTX BLOCK
A COMBINATION OF THE ABOVE	TORLON ROLLER BEARING	RACING BLOCK

## Which Size/Load Block?

- Each Lewmar block has a specified Working Load Limit (WLL), listed in the product specification table
- Match the input from Control Line/Winch to the WLL of the block
- Note that the line's angle of deflection around the sheave affects the load exerted on the block (see table below)

CHANGE OF ANGLE	BLOCK LOAD AS % OF LINE LOAD	CHANGE OF ANGLE	BLOCK LOAD AS % OF LINE LOAD
180°	200%	90°	141%
170°	199%	80°	129%
160°	197%	70°	115%
150°	193%	60°	100%
140°	187%	50°	84%
135°	184%	45°	76%
130°	181%	40°	68%
120°	173%	30°	52%
110°	164%	20°	35%
100°	153%	10°	17%
		0°	0%

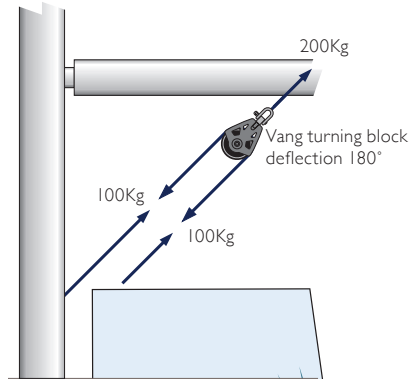
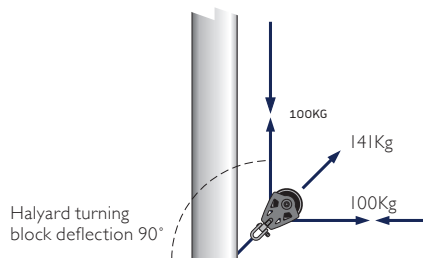
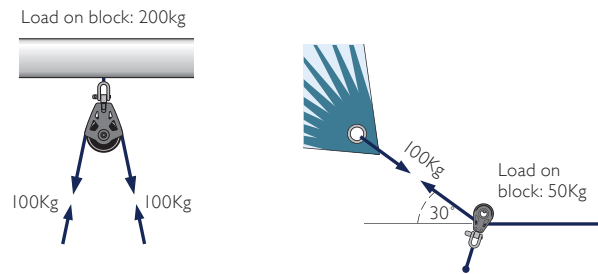

VERTICAL GENOA SHEET ANGLE	TOW LOAD AS % OF SHEET LOAD
70°	65%
60°	50%
50°	35%
40°	25%

MAINSHEET TRAVELLER TOWING LOAD	
GUIDE % OF MAINSHEET LOAD	25%

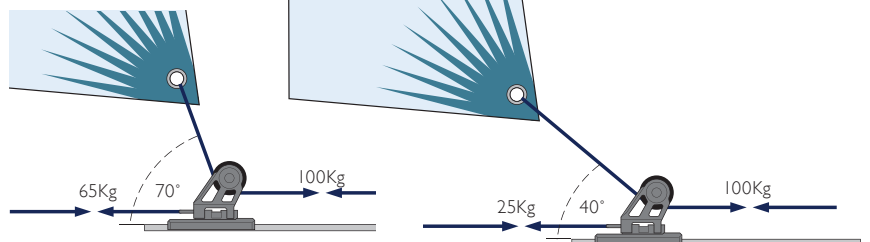

## Additional Recommendations

- Always choose a sheave diameter at least 7x the line diameter.
- Ensure that blocks are always fitted so they align with the lines passing through them, particularly on multiple blocks and where lines are periodically slack.
- All Lewmar products have been designed, tested, and developed to achieve best possible efficiency; however, no purchase system is 100% efficient. The force achieved at the working end of the purchase will be slightly less than the human load multiplied by the purchase. When calculating the purchase required to achieve a known load, we would recommend allowing a factor of 1.05 per block. Multiply by the number of 180° turns in the rope make in a system to be certain of 'fingertip' control.

# 8. Hardware

## Mainsheet Systems – Typical Arrangement

4:1 Dedicated Winch

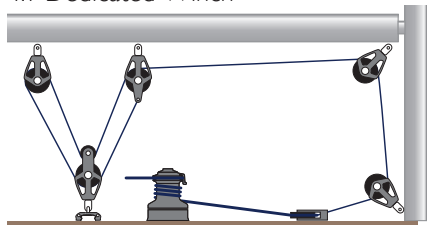

Half German

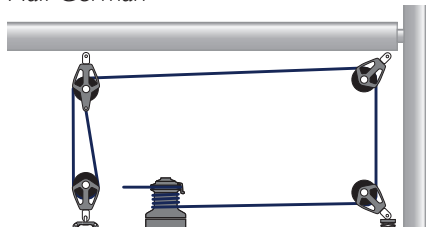

Double German

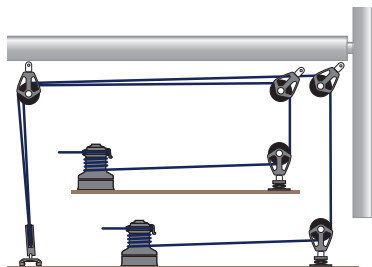

4:1 Fiddle

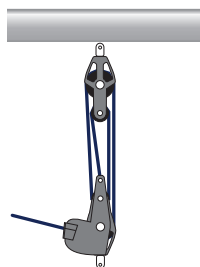

6:1 Triple



6:1/24:1

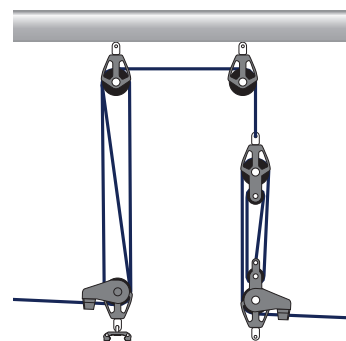

## Halyards

Single Halyard

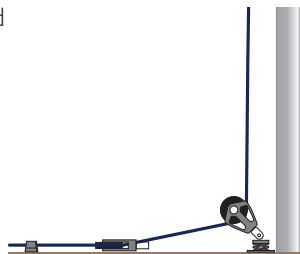

3 Halyard

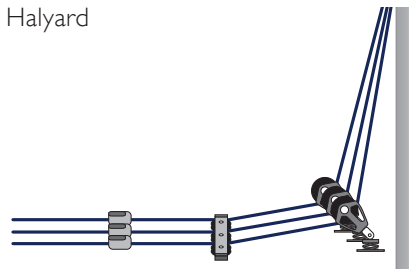

## Genoa Systems

Plunger Car

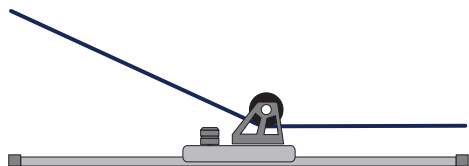

2:1



3:1



8:1

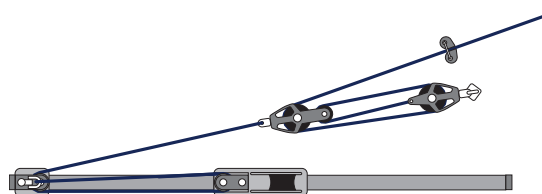

## Boom Vang

4:1 Fiddle

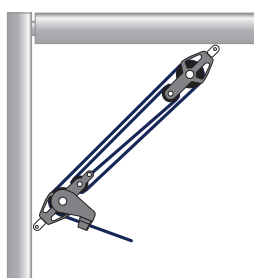

6:1 Double Ended

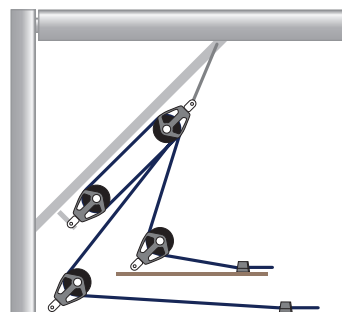



### Outhaul

2:1 Internal Cascade

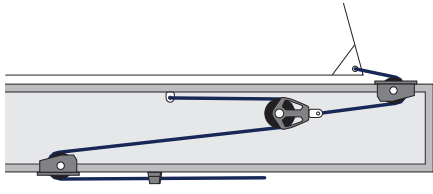

4:1 External Cascade

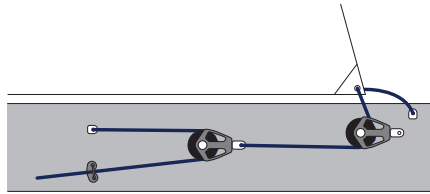

4:1 Internal Cascade

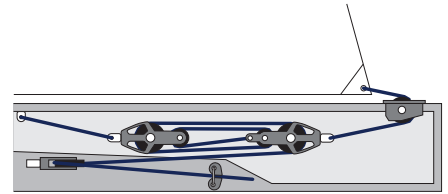

### Traveller Systems

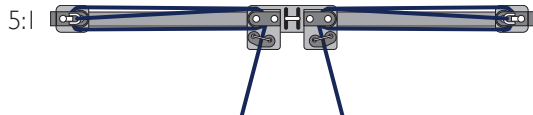
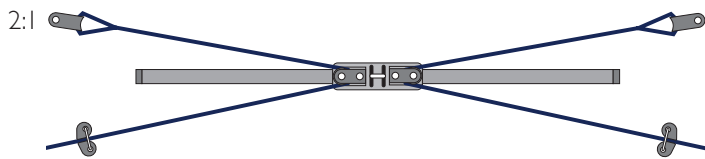

### Cunningham

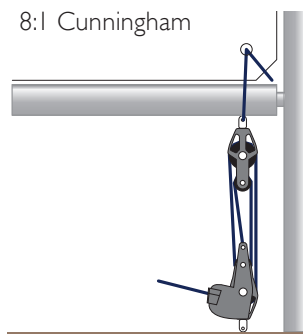
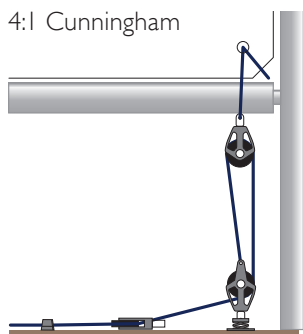

### Barber Hauler

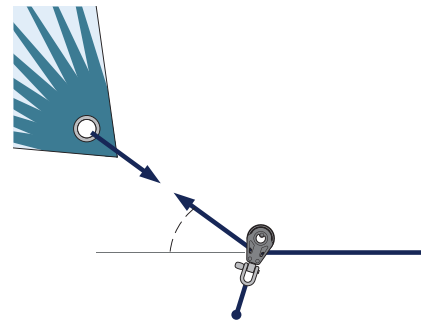

### Miscellaneous

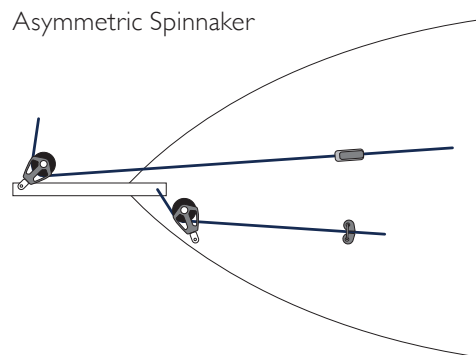

# 8. Hardware

## Blocks – Selection Guide

BLOCK TYPE	APPLICATION	BOAT LENGTH												
		M FT	16	6.1 20	7.3 24	8.5 28	9.7 32	11 36	12.2 40	13.4 44	14.6 48	15.8 52	17.1 56	18.3 60
CONTROL BLOCKS	MAIN SHEET - END BOOM SINGLE/FIDDLE BLOCKS		30 CONTROL	40 CONTROL										
	MAIN SHEET - END BOOM DOUBLE/TRIPLE BLOCKS		30 CONTROL	40 CONTROL										
	HALYARD BLOCKS		30	40 CONTROL										
	MAST BASE AND GENERAL CONTROL BLOCKS		30 CONTROL		40 CONTROL									
SYNCHRO	MAIN SHEET - END BOOM				50 SYNCHRO	60	72 SYNCHRO	90 SYNCHRO						
	MAIN SHEET - MID BOOM				50 SYNCHRO	60	72 SYNCHRO	90 SYNCHRO	105 SYNCHRO					
	MAIN & GENOA HALYARDS			60 SYNCHRO	72 SYNCHRO	90 SYNCHRO	105 SYNCHRO							
	SPINNAKER MAST TOP BLOCKS		50 SYNCHRO	60 SYNCHRO	72 SYNCHRO	90 SYNCHRO	105 SYNCHRO							
	SPINNAKER SHEET		50 SYNCHRO	60 SYNCHRO	72 SYNCHRO	90 SYNCHRO	105 SYNCHRO							
	SPINNAKER GUY		50 SYNCHRO	60 SYNCHRO	72 SYNCHRO	90 SYNCHRO	105 SYNCHRO							
	SPINNAKER DOWNHAUL		50 SYNCHRO	60 SYNCHRO	72 SYNCHRO	90 SYNCHRO								
	BOOM VANGS		50 SYNCHRO	60 SYNCHRO	72 SYNCHRO	90 SYNCHRO								
	BACKSTAY TENSIONERS		50 SYNCHRO	60 SYNCHRO	72 SYNCHRO									
HTX	MAIN SHEET - END BOOM			50 HTX	60 HTX	72 HTX	90 HTX							
	MAIN SHEET - MID BOOM			50 HTX	60 HTX	72 HTX	90 HTX							
	MAIN & GENOA HALYARDS		50 HTX	60 HTX	72 HTX	90 HTX								
	SPINNAKER MAST TOP BLOCKS		50 HTX	60 HTX	72 HTX	90 HTX								
	SPINNAKER SHEET		50 HTX	60 HTX	72 HTX	90 HTX								
	SPINNAKER GUY		50 HTX	60 HTX	72 HTX	90 HTX								
	SPINNAKER DOWNHAUL		50 HTX	60 HTX	72 HTX									
	BOOM VANGS		50 HTX	60 HTX	72 HTX									
	BACKSTAY TENSIONERS		50 HTX	60 HTX										
RACING	MAIN SHEET - END BOOM SINGLES			60 HL RACING	80 RACING	80 HL RACING								
	MAIN SHEET - END BOOM DOUBLE/TRIPLE BLOCKS				60 HL RACING	80 RACING	80 HL RACING							
	MAIN SHEET - MID BOOM SINGLES		60 HL RACING	80 RACING	80 RACING									
	MAIN SHEET - MID BOOM DOUBLE/TRIPLE BLOCKS			60 HL RACING	80	80 HL RACING								
	HALYARD (BLOCK & PADEYE AT MAST BASE)		60 HL RACING	80	80 HL RACING									
	SPINNAKER MAST TOP BLOCKS			60 HL RACING	80 RACING	80 HL RACING								
	SPINNAKER MAST SHEETS BLOCKS / GUY BLOCKS			60 HL RACING	80 RACING	80 HL RACING								
	BOOM VANG (FIRST BLOCK IN CASCADE)		60 HL RACING	80 RACING										

## Footblock – Selection Guide

BLOCK TYPE	SHEET DEFLECTION	HAND LOAD	WINCH SIZE										
			8	15/16	30	40	45	50	55	65	70	80	
SYNCHRO	90°			60 SYNCHRO	72 SYNCHRO	90 SYNCHRO							
	180°			60 SYNCHRO	72 SYNCHRO	90 SYNCHRO							
RACING	90°			80 RACING	60 HL RACING	80 HL RACING	105 HL RACING						
	180°			80 RACING	60 HL RACING	80 HL RACING	105 HL RACING	130 HL RACING	155 HL RACING				

### Control Blocks

30 CONTROL  
40 CONTROL

### Synchro Blocks

50 SYNCHRO 90 SYNCHRO  
60 SYNCHRO 105 SYNCHRO  
72 SYNCHRO

### HTX Blocks

50 HTX 72 HTX  
60 HTX 90 HTX

### Racing Blocks

60 HL RACING 80 HL RACING  
80 RACING 105 HL RACING



## Control Blocks

Ideal for use with hand-held loads, Lewmar's Control Blocks feature lightweight, performance load-bearing capacity. MRT (Metal Replacement Technology) and a stainless steel central race and balls provide a weight advantage, while Long Fibre Technology offers exceptional strength and durability. The open design allows sand and salt to be flushed out easily, keeping maintenance simple.

- Lightweight
- Very high strength
- Impact resistant
- Reduced friction
- Easy maintenance
- Optimised for hand control

- A** Long fibre cheek
- B** High strength glass-filled sheave
- C** Marked sheave - Showing line size and safe working load
- D** Stainless steel balls and ball groove - Avoids deformation and loss of performance



### Applications

Ball bearing blocks are typically used for medium and dynamic loads in:

- Control line applications
- Mainsheets for dinghies and keelboats
- Spinnaker sheets, barber haulers
- Genoa sheets
- Dinghy applications



# 8. Hardware



## Control Blocks

### Single Stand Up



PART NO	SHEAVE Ø	WORKING LOAD LIMIT		WEIGHT	
		KG	LB	G	OZ
29901320BK	30	200	440	30	1
29901420BK	40	240	528	54	1.9

### Single



PART NO	SHEAVE Ø	WORKING LOAD LIMIT		WEIGHT	
		KG	LB	G	OZ
29901321BK	30	200	440	28	1
29901421BK	40	240	528	52	1.83

### Double



PART NO	SHEAVE Ø	WORKING LOAD LIMIT		WEIGHT	
		KG	LB	G	OZ
29901322BK	30	300	660	47	1.65
29901422BK	40	480	1056	112.5	3.97

### Triple



PART NO	SHEAVE Ø	WORKING LOAD LIMIT		WEIGHT	
		KG	LB	G	OZ
29901323BK	30	500	1100	85	3
29901423BK	40	720	1584	187.5	6.61

### Single & Becket



PART NO	SHEAVE Ø	WORKING LOAD LIMIT		WEIGHT	
		KG	LB	G	OZ
29901324BK	30	200	440	33	1.16
29901424BK	40	240	528	56.5	1.99

### Double & Becket



PART NO	SHEAVE Ø	WORKING LOAD LIMIT		WEIGHT	
		KG	LB	G	OZ
29901325BK	30	300	660	50	1.76
29901425BK	40	480	1056	116.5	4.11

## Control Blocks

### Triple & Becket



PART NO	SHEAVE Ø	WORKING LOAD LIMIT		WEIGHT	
		KG	LB	G	OZ
29901326BK	30	500	1100	90	3.17
29901426BK	40	720	1584	192.5	6.79

### Single Fixed Strap



PART NO	SHEAVE Ø	WORKING LOAD LIMIT		WEIGHT	
		KG	LB	G	OZ
29901341BK	30	200	440	26	0.92
29901441BK	40	240	528	44	1.55

### Shackle Post Dimensions

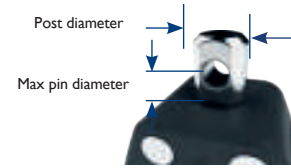

	POST DIAMETER		TO FIT MAX PIN Ø	
	MM	IN	MM	IN
30MM SINGLE / DOUBLE	7.1	2/7	4	5/32
30MM TRIPLE	9.25	3/8	5	3/16
40MM SINGLE / DOUBLE	8.0	5/16	4	5/32
40MM TRIPLE	11.5	7/16	6	1/4

### Line Size



	MAX LINE SIZE	
	MM	IN
30MM CONTROL	8	5/16
40MM CONTROL	10	3/8

### Single Fixed Strap - St. Steel Sheave



DESIGNED FOR USE WITH WIRE.  
30MM SUITS MAX 3MM (1/8") WIRE  
40MM SUITS MAX 6MM (1/4") WIRE

PART NO	SHEAVE Ø	WORKING LOAD LIMIT		WEIGHT	
		KG	LB	G	OZ
29901301BK	30	240	528	36	1.2
29901401BK	40	400	890	76	2.5

### Single Fixed Strap & Becket



PART NO	SHEAVE Ø	WORKING LOAD LIMIT		WEIGHT	
		KG	LB	G	OZ
29901314BK	30	200	440	31	1.09

### Suitable Block Upstand

30 and 40mm Control blocks fit block upstand part no 29904046  
For more info refer to p. 315



### Fit Snap Shackle



	FIT SNAP SHACKLE
30MM CONTROL SINGLE / DOUBLE	29925040
30MM CONTROL TRIPLE	29926040
40MM CONTROL SINGLE / DOUBLE	29925040
40MM CONTROL TRIPLE	29927240

For more info refer to p. 316

### Triple & Cleat



PART NO	SHEAVE Ø	WORKING LOAD LIMIT*		WEIGHT	
		KG	LB	G	OZ
29901328BK	30	500	1100	135	4.76
29901429BK	40	720	1584	247.5	8.73

### Single with Becket & Cleat



PART NO	SHEAVE Ø	WORKING LOAD LIMIT*		WEIGHT	
		KG	LB	G	OZ
29901428BK	40	240	528	56.5	1.99

\* Block WLL, cleat WLL 120kg

### Cleat Used

Control blocks with cam use the following cleats



	USE CLEAT	WORKING LOAD LIMIT	
		KG	LB
30 / 40MM CONTROL	29104100BK	120	264

### Pad Eyes



Wide range of pad eyes available, refer to page 320 for more information

\* Block WLL, cleat WLL 120kg

# 8. Hardware

## Control Blocks

### Triple with Becket & Cleat



PART NO	SHEAVE Ø	WORKING LOAD LIMIT*		WEIGHT	
		KG	LB	G	OZ
29901330BK	30	500	1100	140	5
29901430BK	40	720	1584	252.5	8.91

\* Block WLL, cleat WLL 120kg

### Single Web



PART NO	SHEAVE Ø	WORKING LOAD LIMIT		WEIGHT	
		KG	LB	G	OZ
29901447BK	40	240	528	39.5	1.39

### Thru-Deck Block



PART NO	SHEAVE Ø	WORKING LOAD LIMIT		WEIGHT	
		KG	LB	G	OZ
29901361BK	30 SINGLE	200	440	26	0.92
29901362BK	30 TANDEM	200	440	45	1.59

### Cheekblock



PART NO	SHEAVE Ø	WORKING LOAD LIMIT		WEIGHT	
		KG	LB	G	OZ
29901360BK	30	200	440	18.5	0.65
29901460BK	40	240	528	43	1.52

### Vertical Lead Block



PART NO	SHEAVE Ø	WORKING LOAD LIMIT		WEIGHT	
		KG	LB	G	OZ
29901363BK*	30	200	440	48	1.69
29901463BK	40	240	528	70	2.4

\* 30mm has no fairlead

### Pivoting Exit Block



PART NO	SHEAVE Ø	WORKING LOAD LIMIT*		WEIGHT	
		KG	LB	G	OZ
29901365BK	30	200	440	80	2.82

\* Block WLL, cleat WLL 120kg

### Linked Blocks



PART NO	SHEAVE Ø	WORKING LOAD LIMIT		WEIGHT	
		KG	LB	G	OZ
29901411BK	40	240	528	88	3.1

### Footblock



PART NO	SHEAVE Ø	WORKING LOAD LIMIT		WEIGHT	
		KG	LB	G	OZ
29194061	40 SINGLE	750	1653	66	2.33
29194062	40 DOUBLE	750	1653	121	4.27

COMES WITH A STAINLESS STEEL BASE PLATE AND CAN BE USED AS MINIATURE ORGANISERS OR DEFLECTORS FOR LINES BEING RETURNED TO THE COCKPIT.  
USE M8 (5/16) FIXINGS - NOT INCLUDED

### Tweaker Block



PART NO	SHEAVE Ø	WORKING LOAD LIMIT		WEIGHT	
		KG	LB	G	OZ
29900240	30	120	265	28	1
29900340	40	140	309	76	3

## 60mm Ratchet Blocks

Only suitable to use with hand loads. For winched loads, refer to the Synchro, HTX or Racing ranges.



### Single Ratchet



PART NO	SHEAVE Ø	WORKING LOAD LIMIT		WEIGHT	
		KG	LB	G	OZ
29901661BK	60	400	882	126	4.3

### Shackle Post Dimensions

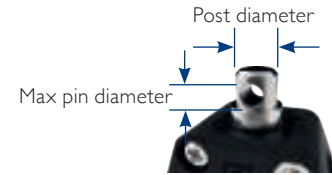

	POST DIAMETER		TO FIT MAX PIN Ø	
	MM	IN	MM	IN
60MM RATCHET SINGLE	9.5	3/8	5	3/16
60MM RATCHET TRIPLE	10.0	2/5	6	1/4

### Line Size



	MAX LINE SIZE	
	MM	IN
60MM RATCHET	10	3/8

### Single Ratchet & Becket



PART NO	SHEAVE Ø	WORKING LOAD LIMIT		WEIGHT	
		KG	LB	G	OZ
29901665BK	60	400	882	141	4.8

### Single Ratchet & Cleat



PART NO	SHEAVE Ø	WORKING LOAD LIMIT*		WEIGHT	
		KG	LB	G	OZ
29901667BK	60	400	882	288	10.1

\* Refers to block WLL, cleat WLL 180kg

### Fit Snap Shackle

	FIT SNAP SHACKLE
60MM RATCHET SINGLE	29926040
60MM RATCHET TRIPLE	29927240



For more info refer to p. 316

### Fit Traveller Upstand



	FIT TRAVELLER UPSTAND
60MM SINGLE RATCHET	SIZE 1 NTR
60MM TRIPLE RATCHET	SIZE 2 NTR & HTX

### Triple Ratchet & Cleat



PART NO	SHEAVE Ø	WORKING LOAD LIMIT*		WEIGHT	
		KG	LB	G	OZ
29901668BK	60	1000	2204	524	17.7

\* Refers to block WLL, cleat WLL 180kg

### Triple Ratchet, Becket & Cleat



PART NO	SHEAVE Ø	WORKING LOAD LIMIT*		WEIGHT	
		KG	LB	G	OZ
29901670BK	60	1000	2204	538	18.2

\* Refers to block WLL, cleat WLL 180kg

### Suitable Block Upstand

60mm triple ratchet blocks fits upstand part no 29904050  
For more info refer to p. 315



### Cleat



	USE CLEAT	WORKING LOAD LIMIT	
		KG	LB
60MM RATCHET BLOCK	29104110BK	180	396

### Pad Eyes



Wide range of pad eyes available, refer to page 320 for more information

## 8. Hardware



### Synchro Blocks

Lewmar Synchro blocks are engineered for speed, efficiency and superior handling. We use a combination of scientifically optimised block geometry, a Free-Spin bearing and self-aligning head to reduce friction and increase efficiency by up to 40% over budget blocks on mainsheet systems.

Each component is perfectly synchronised with the movement of the rope, providing you with an easier, smoother transfer of power from deck to sail and less wear on your rope.

- Stainless steel strap for improved strength and longer service life
- Stiff glass fibre reinforced cheeks to prevent lines from wedging
- Simple switch to change from swivelling to fixed shackle

- **A** Easy to use shackle post lock
- **B** Shackle post – Fits travellers
- **C** Lock mechanism enables 30° float
- **D** Larger sheave diameter – Minimises rope friction
- **E** High density free-spin bearing - reduces axle diameter for superior efficiency

### Applications

Plain bearing blocks are typically used for heavy and static loads in:

- Halyard tuning
- Mainsheet systems
- Mast foot blocks
- Mast head blocks
- Boom vang

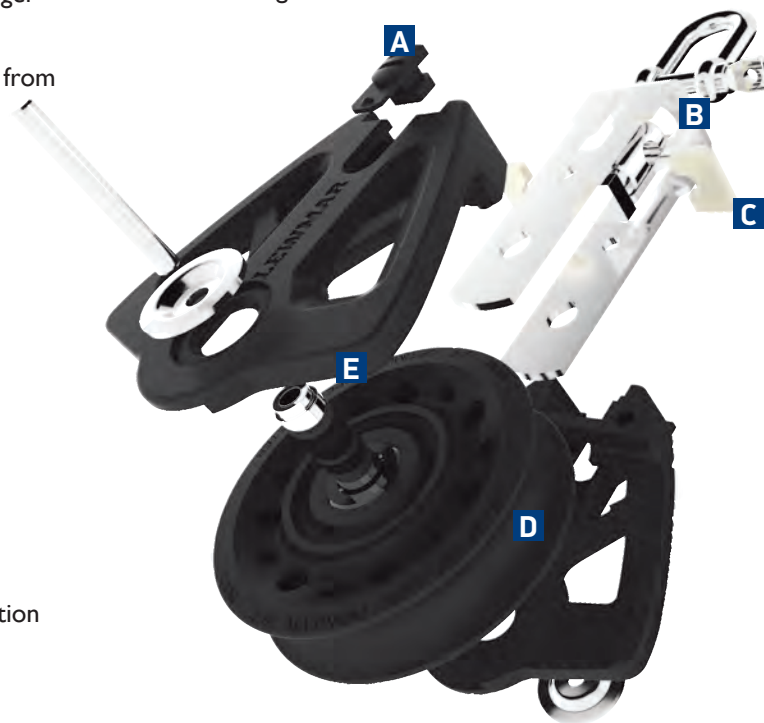



## Synchro Blocks

### Head Design

Head can be positioned for use in line or at 90 degrees – or left to rotate freely when in unlocked position. When locked allows 30° “float” on shackle post to improve alignment of block.



### Higher efficiency – for faster sail handling and less rope wear

Independent tests show Synchro blocks offer increased efficiency over conventional designs. Calculations over a 6-block mainsheet system, indicated Synchro blocks can deliver up to 40% greater efficiency than budget products – resulting in better responsiveness and improved sailing performance.

### Efficiency improvements in multi block systems

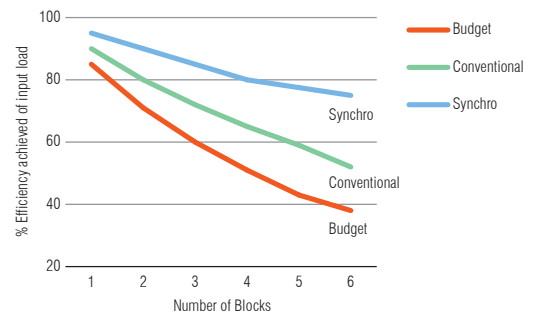

### Shackle Post Dimensions

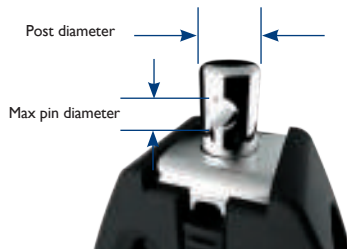

	POST DIAMETER		TO FIT MAX PIN Ø	
	MM	IN	MM	IN
50MM SYNCHRO	7.9	5/16	4	5/32
60MM SYNCHRO	9.4	3/8	5	3/16
72MM SYNCHRO	11.9	15/32	6	1/4
90MM SYNCHRO	16.5	21/32	9.8	3/8

### Suitable Traveller Upstand



FIT TRAVELLER UPSTAND	
50MM SYNCHRO	
60MM SYNCHRO	SIZE 1 NTR
72MM SYNCHRO	SIZE 1 HTX/ SIZE 2 NTR
90MM SYNCHRO	SIZE 2 HTX/ SIZE 3 NTR

### Suitable Snap Shackles



FIT SNAP SHACKLE	
50MM SYNCHRO	29925040
60MM SYNCHRO	29926040
72MM SYNCHRO	29927240
90MM SYNCHRO	29929040

### Cleat Used



	USE CLEAT	WORKING LOAD LIMIT	
		KG	LB
50MM SYNCHRO	29104100BK	120	264
60MM SYNCHRO	29104110BK	180	396
72MM SYNCHRO	29104110BK	180	396

### Line Size



	OPTIMUM LINE SIZE		MAX LINE SIZE	
	MM	IN	MM	IN
50MM SYNCHRO	6	1/4	10	3/8
60MM SYNCHRO	8	5/16	10	3/8
72MM SYNCHRO	10	3/8	12	1/2
90MM SYNCHRO	12	1/2	14	9/16

### Suitable Block Upstands



Rubber boot upstand kit  
 29195065 fits 60mm Synchro  
 29196065 fits 72mm Synchro  
 29197265 fits 90mm Synchro



Spring upstand  
 29904050 fits 50mm Synchro

### Pad Eyes



Wide range of pad eyes available, refer to page 320 for more information

For information about block upstand refer to p 315

# 8. Hardware

## Synchro Blocks

Single



PART NO	SHEAVE Ø	WORKING LOAD LIMIT		WEIGHT	
		KG	LB	G	OZ
29925001BK	50	450	990	67	2.36
29926001BK	60	800	1760	115	4.06
29927201BK	72	1100	2420	190	6.69
29929001BK	90	2000	4400	413	14.57

Double



PART NO	SHEAVE Ø	WORKING LOAD LIMIT		WEIGHT	
		KG	LB	G	OZ
29925002BK	50	450	990	142	5.01
29926002BK	60	800	1760	251	8.84
29927202BK	72	1100	2420	406	14.29
29929002BK	90	2000	4400	966	34.00

Triple



PART NO	SHEAVE Ø	WORKING LOAD LIMIT		WEIGHT	
		KG	LB	G	OZ
29925003BK	50	450	990	226	7.96
29926003BK	60	800	1760	371	13.06
29927203BK	72	1100	2420	618	21.75
29929003BK	90	2000	4400	1389	48.89

Single & Becket



PART NO	SHEAVE Ø	WORKING LOAD LIMIT		WEIGHT	
		KG	LB	G	OZ
29925004BK	50	450	990	81	2.85
29926004BK	60	800	1760	127	4.48
29927204BK	72	1100	2420	210	7.41
29929004BK	90	2000	4400	458	16.15

Double & Becket



PART NO	SHEAVE Ø	WORKING LOAD LIMIT		WEIGHT	
		KG	LB	G	OZ
29925005BK	50	450	990	164	5.77
29926005BK	60	800	1760	261	9.19
29927205BK	72	1100	2420	415	14.61

Single Becket & Cam



PART NO	SHEAVE Ø	WORKING LOAD LIMIT		WEIGHT	
		KG	LB	G	OZ
29925009BK	50	450	990	123	4.30

\* Block WLL, cleat WLL shown p297

Triple, Becket & Cam



PART NO	SHEAVE Ø	WORKING LOAD LIMIT *		WEIGHT	
		KG	LB	G	OZ
29925010BK	50	450	990	282	9.93
29926010BK	60	800	1760	447	15.73
29927210BK	72	1100	2420	820	28.86

\* Block WLL, cleat WLL shown p297

Single Fiddle



PART NO	SHEAVE Ø	WORKING LOAD LIMIT		WEIGHT	
		KG	LB	G	OZ
29925031BK	50	450	990	94	3.31
29926031BK	60	800	1760	156	5.50
29927231BK	72	1100	2420	250	8.80
29929031BK	90	2000	4400	544	19.19

## Synchro Blocks

### Single Fiddle & Becket



PART NO	SHEAVE Ø	WORKING LOAD LIMIT		WEIGHT	
		KG	LB	G	OZ
29925034BK	50	450	990	98	3.45
29926034BK	60	800	1760	166	5.85
29927234BK	72	1100	2420	275	9.70
29929034BK	90	2000	4400	589	20.77

### Single Fiddle & Cam



PART NO	SHEAVE Ø	WORKING LOAD LIMIT*		WEIGHT	
		KG	LB	G	OZ
29925037BK	50	450	990	139	4.89
29926037BK	60	800	1760	221	7.78
29927237BK	72	1100	2420	339	11.93

\* Block WLL, cleat WLL shown p.297

### Single Fiddle, Becket & Cam



PART NO	SHEAVE Ø	WORKING LOAD LIMIT*		WEIGHT	
		KG	LB	G	OZ
29925039BK	50	450	990	145	5.10
29926039BK	60	800	1760	234	8.24
29927239BK	72	1100	2420	356	12.53
29929039BK	90	2000	4400	879	27.12

\* Block WLL, cleat WLL shown p.297

## Halyard Block



The toggle head of the halyard blocks is designed to fit on the studs commonly found at mast bases – check the diameter of the stud against the width of the block jaws (A) and pin diameter (B)

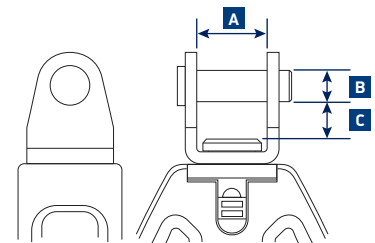

PART NO	SHEAVE DIAMETER	WORKING LOAD LIMIT		WEIGHT		HEAD DETAILS					
						A		B		C	
						WIDTH	PIN	SPACE TO PIN	MM	IN	
29925021BK	50	450	990	73	2.57	13	1/2	5	3/16	8.2	5/16
29926021BK	60	800	1760	122	4.29	15	37/64	6	7/32	6.9	9/32
29927221BK	72	1100	2420	198	6.98	18	45/64	8	5/16	9.6	3/8
29929021BK	90	2000	4400	414	14.57	23	29/32	10	25/64	13.9	17/32



# 8. Hardware

## Synchro Footblocks

Synchro Footblocks feature alloy cheeks, fixing isolators, and a moulded base plate to prevent sealant ingress into the sheave.

Jamming footblocks are designed to hold light hand loads only.

- Standard and jammer options can be double stacked
- Two-step jammer action keeps lever close to side of the block
- Optimised jammer shape holds line central on the sheave
- Tough alloy cheeks
- Synchro sheave loads match the same sized blocks
- Twin fixings with inserts
- Wide head for a solid base, block will not “roll” on the deck
- Moulded base plate with recess to hold sealant around fixing screws and prevent ingress onto the bearing and sheave

## Aluminium Footblock



## Aluminium Footblock with Jammer



PART NO	SHEAVE Ø	WORKING LOAD LIMIT		WEIGHT	
		KG	LB	G	OZ
29926061BK	60	800	176.4	162	5.70
29927261BK	72	1200	264.5	229	8.10
29929061BK	90	2000	440.9	430	15.20

PART NO	SHEAVE Ø	WORKING LOAD LIMIT		WEIGHT	
		KG	LB	G	OZ
29926064BK	60	800	176.4	190	6.70
29927264BK	72	1200	264.5	250	8.80
29929064BK	90	2000	440.9	480	16.90

USE M8 (5/16) FIXINGS FOR THE 60/72MM SHEAVES AND M10 FOR THE 90MM SHEAVES - NOT INCLUDED

USE M8 (5/16) FIXINGS FOR THE 60/72MM SHEAVES AND M10 FOR THE 90MM SHEAVES - NOT INCLUDED

## Synchro Footblock Footprint

PART NO	A		B		C	
	MM	IN	MM	IN	MM	IN
60MM FOOTBLOCK	98.0	3 <sup>7</sup> / <sub>8</sub>	51.0	2	59	2 <sup>5</sup> / <sub>16</sub>
72MM FOOTBLOCK	110.6	4 <sup>5</sup> / <sub>16</sub>	58.0	2 <sup>5</sup> / <sub>16</sub>	71	2 <sup>13</sup> / <sub>16</sub>
90MM FOOTBLOCK	134.0	5 <sup>1</sup> / <sub>16</sub>	69.0	2 <sup>11</sup> / <sub>16</sub>	89	3 <sup>1</sup> / <sub>2</sub>

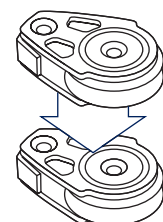
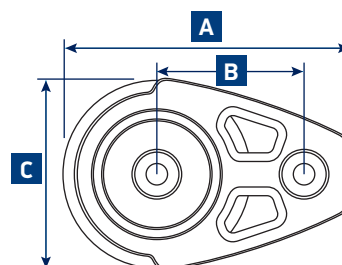

STANDARD AND JAMMER OPTIONS CAN BE DOUBLE STACKED THE UPPER SHEAVE SHOULD NOT BE LOADED BEYOND 60% OF WLL



## HTX Blocks

Years of design and manufacturing experience, combined with collaboration with boat builders, designers, and sailors, has resulted in the Lewmar HTX Hardware Range. Drawing upon the design of the racing range, the HTX blocks are constructed simply from high quality materials, providing enhanced reliability. Ideal for frequently adjusted, highly loaded systems using modern line technology and reduced line diameters.

- Strong aluminium side cheeks
- Central plain bearing for efficiency at high loads
- Side thrust Delrin ball bearings
- Head design inspired by Lewmar Racing Range, complete with grub screw swivel head locking mechanism



- A** Alloy cheeks
- B** Side thrust ball bearings
- C** Central plain bearing
- D** Head pin design inspired by Lewmar Racing series block
- E** High Load capacity and large line size

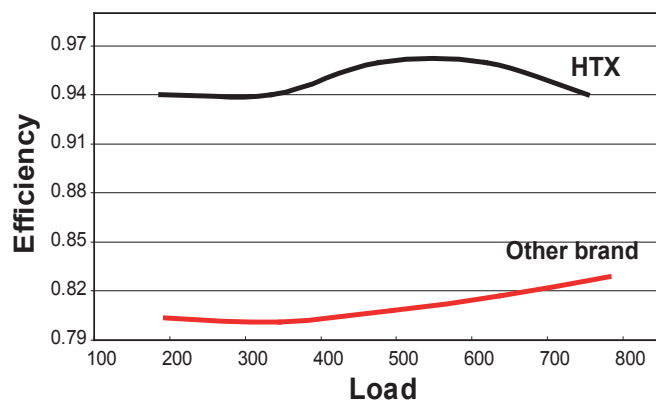

Higher efficiency – for faster sail handling and less rope wear.

HTX blocks are more efficient than alternative brand using similar material due to machined bearing pin surface.

HTX block efficiency improves above 450kg as acetal sheaves become self-lubricating at this point.

# 8. Hardware

## HTX Blocks

### Single



PART NO	SHEAVE Ø	WORKING LOAD LIMIT		WEIGHT	
		KG	LB	G	OZ
29195001	50	800	1762	135	4.7
29196001	60	1100	2422	215	7.5
29197201	72	2000	4405	445	15.6
29199001	90	3500	7709	735	25.8

### Double



PART NO	SHEAVE Ø	WORKING LOAD LIMIT		WEIGHT	
		KG	LB	G	OZ
29195002	50	800	1762	217	7.6
29196002	60	1100	2422	331	11.6
29197202	72	2000	4405	552	19.3

### Triple



PART NO	SHEAVE Ø	WORKING LOAD LIMIT		WEIGHT	
		KG	LB	G	OZ
29195003	50	800	1762	305	10.7
29196003	60	1100	2422	426	14.9

### Single & Becket



PART NO	SHEAVE Ø	WORKING LOAD LIMIT		WEIGHT	
		KG	LB	G	OZ
29195004	50	800	1762	150	5.3
29196004	60	1100	2422	225	7.9
29197204	72	2000	4405	482	16.9
29199004	90	3500	7709	936	32.8

### Double & Becket



PART NO	SHEAVE Ø	WORKING LOAD LIMIT		WEIGHT	
		KG	LB	G	OZ
29195005	50	800	1762	232	8.1
29196005	60	1100	2422	319	11.2

### Single Becket & Cam



PART NO	SHEAVE Ø	WORKING LOAD LIMIT*		WEIGHT	
		KG	LB	G	OZ
29195009	50	800	1762	320	11.2
29196009	60	1100	2422	414	14.5

\* Block WLL, cleat WLL shown p.303

### Triple, Becket & Cam



PART NO	SHEAVE Ø	WORKING LOAD LIMIT*		WEIGHT	
		KG	LB	G	OZ
29195010	50	800	1762	511	17.9
29196010	60	1100	2422	710	24.9

\* Block WLL, cleat WLL shown p.303

### Web Single



PART NO	SHEAVE Ø	WORKING LOAD LIMIT		WEIGHT	
		KG	LB	G	OZ
29195047	50	800	1762	80	2.8
29196047	60	1100	2422	148	5.2
29197247	72	2000	4405	283	9.9

### HTX Blocks

#### Fiddle



PART NO	SHEAVE Ø	WORKING LOAD LIMIT		WEIGHT	
		KG	LB	G	OZ
29195031	50	800	1762	165	5.8
29196031	60	1100	2422	257	9.0
29197231	72	2000	4405	530	18.5

#### Fiddle & Becket



PART NO	SHEAVE Ø	WORKING LOAD LIMIT		WEIGHT	
		KG	LB	G	OZ
29195034	50	800	1762	175	6.1
29196034	60	1100	2422	269	9.4
29197234	72	2000	4405	560	19.6

#### Shackle Post Dimensions

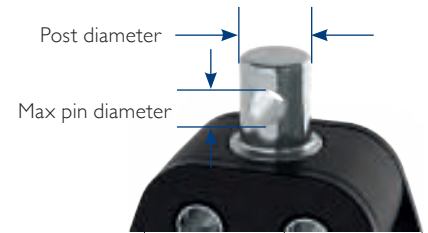

	POST DIAMETER		TO FIT MAX PIN Ø	
	MM	IN	MM	IN
50MM HTX	9.4	3/8	5	3/16
60MM HTX	11.9	15/32	6	1/4
72MM HTX	16.5	21/32	9.8	3/8
90MM HTX	19.8	25/32	10	25/64

#### Line Size



	MAX LINE SIZE	
	MM	IN
50MM HTX	10	3/8
60MM HTX	12	1/2
72MM HTX	14	9/16
90MM HTX	16	5/8

#### Fiddle & Cam



PART NO	SHEAVE Ø	WORKING LOAD LIMIT *		WEIGHT	
		KG	LB	G	OZ
29195037	50	800	1762	335	11.7
29197237	72	2000	4405	748	26.2

\* Block WLL, cleat WLL shown on the right

#### Fiddle, Becket & Cam



PART NO	SHEAVE Ø	WORKING LOAD LIMIT *		WEIGHT	
		KG	LB	G	OZ
29195039	50	800	1762	346	12.1
29196039	60	1100	2422	460	16.1
29197239	72	2000	4405	776	27.2

\* Block WLL, cleat WLL shown on the right

#### Cleat Used



	USE CLEAT	WORKING LOAD LIMIT	
		KG	LB
50MM HTX	29104100BK	120	264
60MM HTX	29104110BK	180	396
72MM HTX	-	230	507

#### Suitable Traveller Upstand



	FIT TRAVELLER UPSTAND	
	SIZE 1 NTR	SIZE 2 HTX
50MM HTX	SIZE 1 NTR	
60MM HTX	SIZE 1 HTX	
72MM HTX	SIZE 2 NTR AND SIZE 2 HTX	
90MM HTX	SIZE 3 NTR	

#### Pad Eyes



Wide range of pad eyes available, refer to page 320 for more information

# 8. Hardware

## HTX Blocks

### Single Stand-Up Block



PART NO	SHEAVE Ø MM	WORKING LOAD LIMIT		WEIGHT		OVERALL DIAMETER		BASE DETAILS FIXINGS DIAMETER		FIXINGS TYPE
		KG	LB	G	OZ	MM	IN	MM	IN	
29195011	50	800	1762	280	10	58	2 5/16	40	1 37/64	4 X M6 (1/4")
29196011	60	1100	2422	350	12.4	58	2 5/16	40	1 37/64	4 X M6 (1/4")
29197211	72	2000	4405	645	22.8	73	2 7/8	50	1 31/32	4 X M8 (5/16")
29199011	90	3500	7709	1115	39.3	76	3"	55	2 11/64	4 X M8 (5/16")

### HTX Footblock



Use M8 (5/16") fixings for the 60/72mm sheaves and M10 (3/8") for the 90mm sheaves (not included)

PART NO	SHEAVE Ø	WORKING LOAD LIMIT		WEIGHT	
		KG	LB	G	OZ
29195061	50	800	1762	145	5.1
29196061	60	1100	2422	158	5.5
29197261	72	2000	4405	283	9.9
29199061	90	3500	7709	672	23.5

### HTX Footblock With Jammer



\*jammer intended to hold hand loads only  
Use M8 (5/16") fixings for the 60/72mm sheaves and M10 (3/8") for the 90mm sheaves (not included)

PART NO	SHEAVE Ø	WORKING LOAD LIMIT		WEIGHT	
		KG	LB	G	OZ
29195064	50	800	1762	107	3.7
29196064	60	1100	2422	170	6.0
29197264	72	2000	4405	320	11.2

### HTX Footblock Footprint

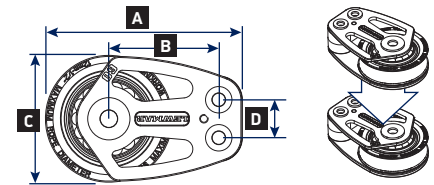

STANDARD AND JAMMER OPTIONS CAN BE DOUBLE STACKED  
THE UPPER SHEAVE SHOULD NOT BE LOADED BEYOND 60% OF WORKING LOAD LIMIT (WLL)

SHEAVE Ø	A	B	C	D
	MM	MM	MM	MM
50	78.7	44	50	16
60	93.2	52	60	18
72	111.2	62	72	22
90	140.5	78	90	24

### Suitable Block Upstand



Rubber boot upstand kit:

29195065 fits 50mm HTX  
29196065 fits 60mm HTX  
29197265 fits 72mm HTX

For more info refer to page 315

### Halyard Block



The toggle head is designed to fit on the studs commonly found at mast bases.  
Check the diameter of the stud against the width of the block jaws (A) and pin diameter (B)

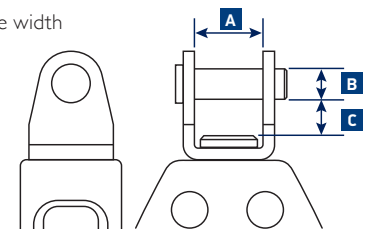

### Fit Snap Shackle



FIT SNAP SHACKLE	
50MM HTX	29926040
60MM HTX	29927240
72MM HTX	29929040

PART NO	SHEAVE Ø MM	WORKING LOAD LIMIT		WEIGHT		HEAD DETAILS					
		KG	LB	G	OZ	A WIDTH		B PIN		C SPACE TO PIN	
						MM	IN	MM	IN	MM	IN
29195021	50	800	1762	160	5.6	15	37/64	6	7/32	8	5/16
29196021	60	1100	2422	227	7.9	18	45/64	8	5/16	10	37/94
29197221	72	2000	4405	410	14.4	23	67/74	10	37/94	9.5	3/8

For more info refer to page 316





## HTX Stainless Steel Blocks

Following the popularity of the HTX blocks, Lewmar have responded to market trends by developing a high-polished, stainless steel edition of the range. Providing a stylish alternative to ubiquitous Lewmar hardware, HTX Stainless Steel Blocks feature all the performance characteristics of the standard range while carrying additional glamour.

### Single



PART NO	SHEAVE Ø	WORKING LOAD LIMIT		WEIGHT	
		KG	LB	G	OZ
27196001	60	1100	2422	270	9.5
27197201	72	2000	4405	560	19.8
27199001	90	3500	7709	920	35.5

### Double



PART NO	SHEAVE Ø	WORKING LOAD LIMIT		WEIGHT	
		KG	LB	G	OZ
27196002	60	1100	2422	415	14.6
27197202	72	2000	4405	690	4.3

### Web Single



PART NO	SHEAVE Ø	WORKING LOAD LIMIT		WEIGHT	
		KG	LB	G	OZ
27195047	50	800	1762	100	3.5

### Single Stand-Up Block



PART NO	SHEAVE Ø	WORKING LOAD LIMIT		WEIGHT		OVERALL DIAMETER		BASE DETAILS		FIXINGS TYPE
		KG	LB	G	OZ	MM	IN	FIXINGS DIAMETER		
								MM	IN	
27196011	60	1100	2422	440	15.5	58	2 <sup>5</sup> / <sub>16</sub>	40	1 <sup>37</sup> / <sub>64</sub>	4 X M6 (1/4")
27197211	72	2000	4405	810	28.6	73	2 <sup>7</sup> / <sub>8</sub>	50	1 <sup>31</sup> / <sub>32</sub>	4 X M8 (5/16")

# 8. Hardware

## HTX Stainless Steel Blocks

### Single & Becket



PART NO	SHEAVE Ø	WORKING LOAD LIMIT		WEIGHT	
		KG	LB	G	OZ
27196004	60	1100	2422	285	10.1
27197204	72	2000	4405	605	21.5

### Fiddle



PART NO	SHEAVE Ø	WORKING LOAD LIMIT		WEIGHT	
		KG	LB	G	OZ
27196031	60	1100	2422	325	11.5

### Fiddle & Cam



PART NO	SHEAVE Ø	WORKING LOAD LIMIT *		WEIGHT	
		KG	LB	G	OZ
27196038	60	1100	2422	500	17.6

\* Block WWL, cleat WLL shown on p303

### Fiddle, Becket & Cam



PART NO	SHEAVE Ø	WORKING LOAD LIMIT *		WEIGHT	
		KG	LB	G	OZ
27196039	60	1100	2422	575	20.3

\* Block WWL, cleat WLL shown on p303

### Halyard Block



The toggle head is designed to fit on the studs commonly found at mast bases. Check the diameter of the stud against the width of the block jaws (A) and pin diameter (B)

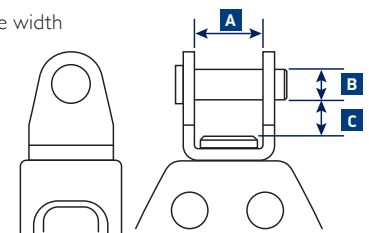

PART NO	SHEAVE Ø	WORKING LOAD LIMIT		WEIGHT		HEAD DETAILS					
		KG	LB	G	OZ	A WIDTH		B PIN		C SPACE TO PIN	
	MM					MM	IN	MM	IN	MM	IN
27196021	60	1100	2422	285	10.1	18	45/64	8	5/16	10	37/94
27197221	72	2000	4405	515	18.2	23	67/74	10	37/94	9.5	3/8

### HTX Footblock



Use M8 (5/16") fixings for the 60/72mm sheaves.

PART NO	SHEAVE Ø	WORKING LOAD LIMIT		WEIGHT	
		KG	LB	G	OZ
27196061	60	1100	2422	200	7.1
27197261	72	2000	4405	355	12.5

### HTX Footblock With Jammer



\*Jammer intended to hold hand loads only  
Use M8 (5/16") fixings for the 60/72mm sheaves

PART NO	SHEAVE Ø	WORKING LOAD LIMIT		WEIGHT	
		KG	LB	G	OZ
27197264	72	2000	4405	480	16.8

### HTX Footblock Footprint

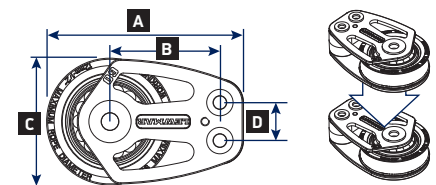

STANDARD AND JAMMER OPTIONS CAN BE DOUBLE STACKED  
THE UPPER SHEAVE SHOULD NOT BE LOADED BEYOND 60% OF WORKING LOAD LIMIT (WLL)

SHEAVE Ø	A	B	C	D
	MM	MM	MM	MM
60	93.2	52	60	18
72	111.2	62	72	22



## Racing Blocks

Lewmar Racing Blocks represent the pinnacle of Lewmar's standard block range. Manufactured from the best materials, they offer incredible strength to weight ratios.

- Lockable head pin
- Highly efficient central bearing
- Delrin thrust balls
- Ratchet fiddle blocks feature alloy ratchet sheaves and recessed ratchet lever



Single



Single & Becket



Single Stand Up



PART NO	SHEAVE Ø	WORKING LOAD LIMIT		WEIGHT	
		KG	LB	G	OZ
29901611BK	60	800	1763	162	5.7
29901811BK	80	1000	2204	251	8.8

PART NO	SHEAVE Ø	WORKING LOAD LIMIT		WEIGHT	
		KG	LB	G	OZ
29901614BK	60	800	1763	170	6.0
29901814BK	80	1000	2204	278	9.8

PART NO	SHEAVE Ø	WORKING LOAD LIMIT		WEIGHT	
		KG	LB	G	OZ
29901600BK	60	800	1763	283	10.0
29941800BK	80	2400	5280	518	18.0

For fixing details refer to the website

# 8. Hardware

## Racing Blocks

### Shackle Post Dimensions

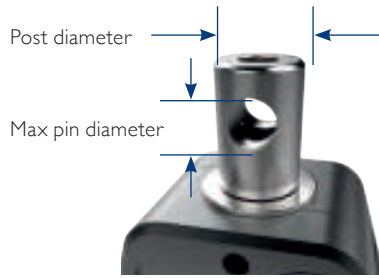

	POST Ø		TO FIT MAX PIN Ø	
	MM	IN	MM	IN
60MM FIDDLES	10.0	3/8	5	3/16
60MM SINGLES	11.0	3/8	6	1/4
60MM DOUBLES	13.8	1/2	8	5/16
80MM SINGLES/ FIDDLES	12.5	1/2	6	1/4
80MM DOUBLE/ TRIPLE	14	9/16	8	5/16
175MM	31.8	1 1/4	16	5/8
200MM	34.7	1 3/8	16	5/8
225MM	38	1 1/2	20	3/4
250MM	46	1 3/4	24.5	1

### Line Size



	MAX LINE SIZE	
	MM	IN
60MM FIDDLE	10	3/8
60/ 80MM	12	1/2
175MM	22	7/8
200MM	22	7/8
225MM	24	15/16
250MM	26	1

### Single Ratchet



PART NO	SHEAVE Ø	WORKING LOAD LIMIT		WEIGHT	
		KG	LB	G	OZ
29901821BK	80	800	1764	291	10.3

### Single Ratchet & Becket



PART NO	SHEAVE Ø	WORKING LOAD LIMIT		WEIGHT	
		KG	LB	G	OZ
29901825BK	80	800	1764	318	11.2

### Single Ratchet, Becket & Cam



PART NO	SHEAVE Ø	WORKING LOAD LIMIT		WEIGHT	
		KG	LB	G	OZ
29901829BK	80	800	1764	503	17.7

### Double



PART NO	SHEAVE Ø	WORKING LOAD LIMIT		WEIGHT	
		KG	LB	G	OZ
29901612BK	60	1440	3175	291	10.3
29901812BK	80	1800	3968	487	17.2

### Double & Becket



PART NO	SHEAVE Ø	WORKING LOAD LIMIT		WEIGHT	
		KG	LB	G	OZ
29901615BK	60	1440	3175	299	10.5
29901815BK	80	1800	3968	514	18.1

### Triple



PART NO	SHEAVE Ø	WORKING LOAD LIMIT		WEIGHT	
		KG	LB	G	OZ
29901813BK	80	2200	4849	724	25.5

### Triple Ratchet & Cam



PART NO	SHEAVE Ø	WORKING LOAD LIMIT		WEIGHT	
		KG	LB	G	OZ
29901828BK	80	2200	4849	949	33.5

## Racing Blocks

### Triple & Becket



PART NO	SHEAVE Ø	WORKING LOAD LIMIT		WEIGHT	
		KG	LB	G	OZ
29901816BK	80	2200	4849	751	26.5

### Triple Ratchet, Becket & Cam



PART NO	SHEAVE Ø	WORKING LOAD LIMIT		WEIGHT	
		KG	LB	G	OZ
29901830BK	80	2200	4849	976	34.4

### Fiddle



PART NO	SHEAVE Ø	WORKING LOAD LIMIT		WEIGHT	
		KG	LB	G	OZ
29901631BK	60	400	882	174	6.1
29901831BK	80	1000	2204	356	12.6

### Fiddle Ratchet & Cam



PART NO	SHEAVE Ø	WORKING LOAD LIMIT		WEIGHT	
		KG	LB	G	OZ
29901822BK	80	1000	2204	567	20.0

### Fiddle Becket



PART NO	SHEAVE Ø	WORKING LOAD LIMIT		WEIGHT	
		KG	LB	G	OZ
29901634BK	60	400	882	190	6.7
29901834BK	80	1000	2204	382	13.5

### Fiddle, Becket & Cam



PART NO	SHEAVE Ø	WORKING LOAD LIMIT		WEIGHT	
		KG	LB	G	OZ
29901639BK	60	400	882	353	12
29901839BK	80	1000	2204	567	20

### Fiddle Ratchet, Becket & Cam



PART NO	SHEAVE Ø	WORKING LOAD LIMIT		WEIGHT	
		KG	LB	G	OZ
29901624BK	60	400	882	362	13.0
29901824BK	80	1000	2204	356	21.0

### Halyard Block



PART NO	SHEAVE Ø	WORKING LOAD LIMIT		WEIGHT	
		KG	LB	G	OZ
29942601BK	60	1400	3080	146	5.2
29942801BK	80	2500	5500	274	9.7

### Halyard Block Head Details

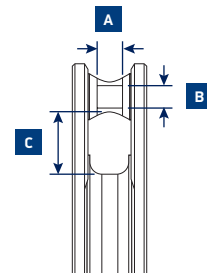

	A		B		C	
	MM	IN	MM	IN	MM	IN
60MM HALYARD	12.8	1/2	6.0	1/4	26.5	1 1/16
80MM HALYARD	14.4	9/16	8.0	5/16	29.5	1 1/4

# 8. Hardware

## Racing Blocks

### Delrin Balls (Bag of 100)



PART NO	WHERE USED	DIAMETER	
		MM	IN
29170022	60 +105 +130 BLOCKS/ FOOTBLOCKS	4.6	3/16
29171022	80 +155 +175 BLOCKS/ FOOTBLOCKS	6.4	1/4



### Footblock Single With Ratchet



FIXINGS SUPPLIED (MAX 35MM DECK THICKNESS):  
SIZE 60 : 2XM6/1XM10, SIZE 80 : 2XM8/1XM12

PART NO	SHEAVE Ø / RATCH. DIR.	WLL		WEIGHT	
		KG	LB	G	OZ
29906621BK	60 CCW (PORT)	400	882	160	5.6
29906622BK	60 CW (STBD)	400	882	160	5.6
29906821BK	80 CCW (PORT)	1000	2204	341	12
29906822BK	80 CW (STBD)	1000	2204	341	12

### Footblock Double



FIXINGS SUPPLIED (MAX 35MM DECK THICKNESS):  
SIZE 60 : 3XM6, SIZE 80 : 3XM8  
SIZE 175 : 2XM12/3XM16, SIZE 250 : 4XM16/2XM20  
\*TOP SHEAVE SHOULD NOT BE LOADED ABOVE 60% OF WLL

PART NO	SHEAVE Ø	WLL*		WEIGHT	
		KG	LB	G	OZ
29906602BK	60	400	882	258	9.1
29906802BK	80	1000	2204	415	15.0
29906172BK	175	10000	22043	11271	397.6

### Footblock Single



FIXINGS SUPPLIED (MAX 35MM DECK THICKNESS):  
SIZE 60 : 3XM6, SIZE 80 : 3XM8  
SIZE 175 : 2XM12/3XM16, SIZE 250 : 4XM16/2XM20

PART NO	SHEAVE Ø	WLL		WEIGHT	
		KG	LB	G	OZ
29906601BK	60	400	882	160	5.6
29906801BK	80	1000	2204	279	9.8
29906171BK	175	10000	22043	2634	92.9

### Racing Footblock Footprint Details

SIZE	L		A		B		C		D		E		F		G	
	MM	IN	MM	IN	MM	IN	MM	IN	MM	IN	MM	IN	MM	IN	MM	IN
60MM	85	3 1/3	20	4/5	10.0	2/5	16	5/8	55	2 1/6	-	-	-	-	-	-
80MM	111	4 3/8	26	1	13.0	1/2	20	4/5	71	2 4/5	-	-	-	-	-	-
175MM	243	9 4/7	33	1 2/7	16.5	2/3	23	1	152	6	25	1	12.5	1/2	26	1
250MM	348	13 5/7	44	1 3/4	22	6/7	29	1 1/7	210	8 1/4	28	1 1/9	28	1 1/9	28	1 1/9

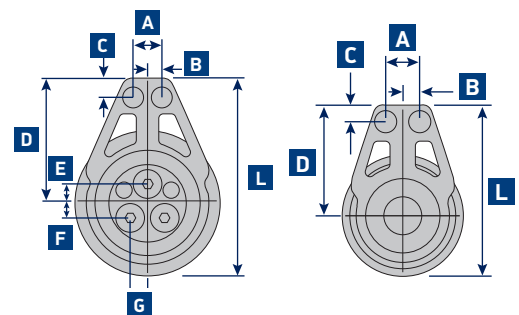

175MM = AS SHOWN  
250MM = 4 CENTRAL FIXINGS

60 & 80MM DIAGRAM



## High Load Racing Blocks

Lewmar High Load Racing Blocks are designed to compete at the highest level. Using cutting-edge materials, the blocks minimise friction to an infinitesimal degree without compromising on load strength.

- A result of extensive testing and innovation
- High-strength alloy construction
- Delrin thrust balls and torlon rollers for supreme performance

### Single



### Single Stand Up



### Single & Becket



PART NO	SHEAVE Ø	WORKING LOAD LIMIT		WEIGHT	
		KG	LB	G	OZ
29941611BK	60	1200	2640	281	9.9
29941801BK	80	2400	5280	337	12
29941101BK	105	3750	8250	605	21.4
29941131BK	130	5000	11000	952	33.6
29941151BK	155	7500	16500	1810	64

PART NO	SHEAVE Ø	WORKING LOAD LIMIT		WEIGHT	
		KG	LB	G	OZ
29941600BK	60	1200	2640	281	9.9
29941800BK	80	2400	5280	518	18
29941100BK	105	3750	8250	727	25.7
29941130BK	130	5000	11000	1404	49.6
29941150BK	155	7500	16500	2396	84.7

PART NO	SHEAVE Ø	WORKING LOAD LIMIT		WEIGHT	
		KG	LB	G	OZ
29941614BK	60	1200	2640	174	6.1
29941804BK	80	2400	5280	358	13
29941104BK	105	3750	8250	640	22.6
29941134BK	130	5000	11000	986	34.8
29941154BK	155	7500	16500	1737	61.4

### Shackle Post Dimensions

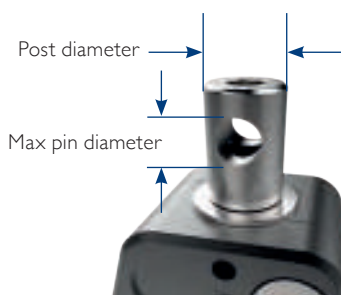

BLOCKS	POST DIAMETER		TO FIT MAX PIN Ø	
	MM	IN	MM	IN
60MM SINGLE	11	3/8	6	1/4
60MM OTHER	13.8	1/2	8	5/16
80MM SINGLE	15	9/16	8	5/16
80MM OTHER	19.8	3/4	10	3/8
105MM SINGLE	19.8	3/4	10	3/8
105MM OTHER	21.8	7/8	12	1/2
130MM BLOCKS	21.8	7/8	12	1/2
155MM BLOCKS	25.8	1	14	9/16

### Line Size



	MAX LINE SIZE	
	MM	IN
60MM BLOCKS	12	1/2
80MM BLOCKS	14	9/16
80MM FIDDLES	12	1/2
105MM BLOCKS	14	9/16
130MM BLOCKS	16	5/8
155MM BLOCKS	18	11/16

# 8. Hardware

## High Load Racing Blocks

Single with Snap Shackle



PART NO	SHEAVE Ø	WORKING LOAD LIMIT		WEIGHT	
		KG	LB	G	OZ
29941808BK	80	2000	4400	496	18

Double



PART NO	SHEAVE Ø	WORKING LOAD LIMIT		WEIGHT	
		KG	LB	G	OZ
29941612BK	60	2000	4400	320	11.3
29941802BK	80	3400	7480	655	23

Double & Becket



PART NO	SHEAVE Ø	WORKING LOAD LIMIT		WEIGHT	
		KG	LB	G	OZ
29941615BK	60	2000	4400	343	12.1
29941805BK	80	3400	7480	685	24

Triple



PART NO	SHEAVE Ø	WORKING LOAD LIMIT		WEIGHT	
		KG	LB	G	OZ
29941613BK	60	2500	5500	428	15.1

Fiddle



PART NO	SHEAVE Ø	WORKING LOAD LIMIT		WEIGHT	
		KG	LB	G	OZ
29941831BK	80	2400	5280	441	16

Fiddle & Becket



PART NO	SHEAVE Ø	WORKING LOAD LIMIT		WEIGHT	
		KG	LB	G	OZ
29941834BK	80	2400	5280	471	17

Web Block



PART NO	SHEAVE Ø	WORKING LOAD LIMIT		WEIGHT	
		KG	LB	G	OZ
29901647BK	60	1400	3086	120	4.2
29901807BK	80	2400	5280	242	8.6
29901107BK	105	3750	8250	417	14.7

Delrin Balls (Bag of 100)



PART NO	WHERE USED	DIAMETER	
		MM	IN
29175022	60HL FOOTBLOCKS	3.2	1/8
29170022	60LL+80HL+105+130 BLOCKS/FOOTBLOCKS	4.6	3/16
29171022	80LL+105+155+175 BLOCKS/FOOTBLOCKS	6.4	1/4

Torlon Rollers for Racing Blocks

PART NO	BAG QTY	BLOCK SIZE
		MM
29900010	22	60
29900011	24	80
29900012	35	105
29900013	47	130
29900014	50	155
29900015	59	175
29900016	68	200
29900017	78	225



## High Load Racing Blocks

### Single Footblock



FIXINGS NOT SUPPLIED:  
 SIZE 60MM 2XM6 / 1XM10  
 SIZE 80MM 2XM8 / 1XM12  
 SIZE 105MM 2XM10 / 1XM12  
 SIZE 130MM 4XM12  
 SIZE 155MM 2XM12 / 2XM16

### Double Footblock



FIXINGS NOT SUPPLIED:  
 SIZE 60MM 2XM6 / 1XM10  
 SIZE 80MM 2XM8 / 1XM12  
 SIZE 105MM 2XM10 / 1XM12  
 SIZE 130MM 4XM12  
 SIZE 155MM 2XM12 / 2XM16

### Shackle Posts

Designed to fit Racing halyard and runner blocks.

Can be used with shackle in-line or at 90° to sheave.



PART NO	SHEAVE Ø	WORKING LOAD LIMIT		WEIGHT	
		KG	LB	G	OZ
29946611BK	60	1400	3080	132	4.7
29946801BK	80	2400	5280	268	9.5
29946101BK	105	3750	8250	490	17.3
29946131BK	130	5500	12100	732	25.9
29946151BK	155	7500	16500	1476	52.2

PART NO	SHEAVE Ø	WORKING LOAD LIMIT*		WEIGHT	
		KG	LB	G	OZ
29946612BK	60	1400	3080	252	8.9
29946802BK	80	2400	5280	500	17.7
29946102BK	105	3750	8250	873	30.8
29946132BK	130	5500	12100	1301	46.0
29946152BK	155	7500	16500	2675	94.5

PART NO.	SUITS	POST DIA.		PIN DIA.		BREAKING LOAD	
		MM	IN	MM	IN	KG	LB
29942606	60MM	17.5	11/16	8	5/16	2800	6170
29942806	80MM	23.75	7/8	10	3/8	5000	11000
29942106	105MM	24	1	10	3/8	6400	14100
29942136	130MM	28	1 1/8	12	1/2	10000	22050
29942156	155MM	36	1 3/8	16	5/8	15000	33050

\*TOP SHEAVE SHOULD NOT BE LOADED ABOVE 60% OF WLL

### Racing Footblock Footprint Details

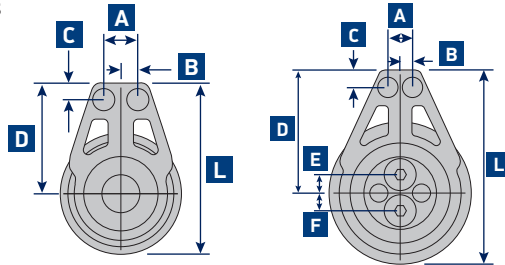

SIZE	L		A		B		C		D		E		F	
	MM	IN	MM	IN	MM	IN	MM	IN	MM	IN	MM	IN	MM	IN
60MM	85	3 1/3	20	4/5	10.0	2/5	16	5/8	55	2 1/8				
80MM	111	4 3/8	26	1	13.0	1/2	20	4/5	71	2 4/5				
105MM	148	5 5/8	35	1 3/8	17.5	2/3	27	1	95	3 3/4	14	1/2	13.6	1/2
130MM	181	7 1/8	40	1 4/7	20.0	4/5	33	1 2/7	111	4 1/3	18	5/7	18	5/7
155MM	216	8 1/2	54	2 1/8	27.0	1	50	2	138	5 3/7	20	4/5	20	4/5

### Halyard and Runner Block Head Details

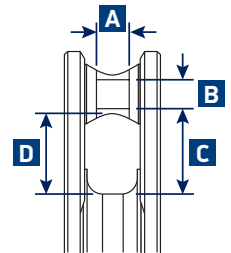

BLOCK	A		B		C		D	
	MM	IN	MM	IN	MM	IN	MM	IN
60MM HL HALYARD	12.8	1/2	8.5	21/64	25.3	1	24.0	15/16
80MM HL HALYARD	14.4	9/16	11.0	7/16	28.0	1 3/4	27.4	1 3/32
80MM RUNNER	11	7/16	11	7/16	28.6	1 9/64	27.8	1 3/32
105MM RUNNER	13	33/64	13	33/64	34.0	1 11/32	32.0	1 1/4
130MM RUNNER	16	5/8	16	5/8	34.0	1 11/32	32.0	1 1/4

### Fixed Halyard Block



PART NO	SHEAVE Ø	WLL		WEIGHT	
		KG	LB	G	OZ
29902800BK	80	2500	5500	300	10.6
29902100BK	105	4000	8817	629	22.2

### Halyard Block



PART NO	SHEAVE Ø	WORKING LOAD LIMIT		WEIGHT	
		KG	LB	G	OZ
29942601BK	60	1400	3080	252	8.9
29942801BK	80	2400	5280	500	17.7
29902101BK	105	3200	7054	457	16.1
29902131BK	130	5000	11021	839	29.6
29902151BK	155	7500	16500	1545	54.5

# 8. Hardware

## High Load Racing Runner Blocks

- Sheaves run on an impregnated composite bearing with dual side thrust bearings for free-running at initial load.
- Optimised cheek design with non-snag bails.
- Also available in Titanium - contact your dealer.
- Breaking load of runner blocks is 2.5 x WLL

### Runner Block



### Runner Block & Becket



PART NO	SHEAVE Ø	WORKING LOAD LIMIT		WEIGHT	
		KG	LB	G	OZ
29902808BK	80	2000	4409	256	9
29902108BK	105	2560	5643	448	15.8
29902138BK	130	4000	8817	776	27.4
29902158BK	155	6000	13226	1418	50
29902178BK	175	8400	18516	2074	73.2
29902208BK	200	10000	22043	4003	141

PART NO	SHEAVE Ø	WORKING LOAD LIMIT		WEIGHT	
		KG	LB	G	OZ
29902809BK	80	2000	4409	265	9.4
29902109BK	105	2560	5643	474	16.7
29902139BK	130	4000	8817	842	29.7
29902159BK	155	6000	13226	1569	55.3
29902179BK	175	8400	18516	2544	89.7
29902209BK	200	10000	22043	4620	163

## Snatch Blocks

Ideal for general spinnaker use, the Snatch Block features the Lewmar snap shackle and soft, synthetic rubber cheeks to handle rough treatment. Where a snatch block is attached in a situation which does not permit full movement, such as through some toe rails, a shackle must be used to ensure full articulation.

Designed for line handling on sail boats only.



19820600  
SIZE 2 SNATCH BLOCK



19830500  
SIZE 3 SNATCH BLOCK



19810600  
SIZE 1 SNATCH BLOCK

PART NO	SIZE	BEARING	SHEAVE MATERIAL	WORKING LOAD LIMIT		BREAKING LOAD		SHEAVE Ø		SHEAVE WIDTH		LINE SIZE		WEIGHT	
				KG	LB	KG	LB	MM	IN	MM	IN	MM	IN	G	OZ
19810600	1	STAINLESS STEEL	DELRIN	1135	2500	2270	5000	66	2 5/8	20	3/4	14	9/16	480	17.0
19820600	2	STAINLESS STEEL	DELRIN	1590	3500	3180	7000	80	3 1/8	20	3/4	16	5/8	880	31.0
19830500	3	NEEDLE ROLLER	ALUMINIUM	2155	4750	4310	9500	80	3 1/8	20	3/4	16	5/8	1040	36.5

## High Load Racing Runner Blocks

### Block Upstands

Lewmar block upstands are designed to hold a block to the deck in a vertical direction for sail control in leisure marine application only.

Their performance depends heavily on the specific application and suitability of installation.

Care must be taken during installation that the block upstand is suitably aligned to the expected load.

The load direction should be as close to perpendicular with the base as possible (as shown on the Alignment illustration). This will maximise the working load of the pad eye.

In addition, the load should be as close to parallel with the bail as possible. The Working Load Limit (WLL) Zones illustration shows the recommended WLL relative to the applied force.

### Working Load Limit (WLL) Zones

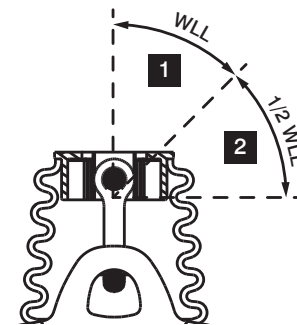

### Alignment

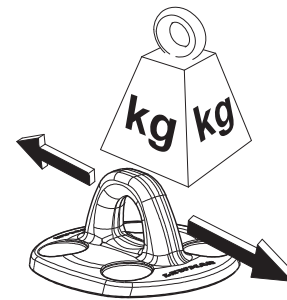

### Spring Block Upstand



PART NO	TO SUIT BLOCK	WORKING LOAD LIMIT ZONE 1		WORKING LOAD LIMIT ZONE 2		WEIGHT		BASE DIA	
		KG	LB	KG	LB	KG	LB	MM	IN
29904046	30 @ 40MM CONTROL	400	990	200	495	24	0.8	1 3/16	1/8
29904050	60MM RATCHET TRIPLE @ 60MM SYNCHRO	400	990	200	495	24	0.8	1 3/4	3/16

### Rubber-Boot Block Upstand with Pad Eye



PART NO	TO SUIT BLOCK	WORKING LOAD LIMIT ZONE 1		WORKING LOAD LIMIT ZONE 2		WEIGHT		BASE DIA	
		KG	LB	KG	LB	G	OZ	MM	IN
29195065	50MM HTX 60MM SYNCHRO 60MM RATCHET SINGLE / FIDDLE	800	1760	400	990	105	3.7	58	2 1/4
29196065	60MM HTX 72MM SYNCHRO 60MM RACING LOW LOAD SINGLE	1100	2420	550	1211	105	3.7	58	2 1/4
29197265	72MM HTX 90MM SYNCHRO	2000	4400	1000	2200	210	7.4	73	2 7/8

## 8. Hardware

### Pivoting Lead Blocks

Lead blocks are a low profile solution for leading halyards or other rig sail controls back to cleats or jammers. Maintains alignment with a variable line entry-angle. The line passes through the centre of the pivot support, remaining as close to the deck as possible.

- Alloy sheave / Alloy cheeks
- Black carbon Acetal ball bearings
- Torlon® ratchet pawl



Pivoting low lead



Pivoting low lead ratchet



Pivoting low lead ratchet with cleat

PART NO	DESCRIPTION	SHEAVE Ø	MAX ROPE Ø		WORKING LOAD LIMIT		WEIGHT		FASTENER Ø		FASTENING CENTRE WIDTH		FASTENING CENTRE LENGTH	
			MM	IN	KG	LB	G	OZ	MM	IN	MM	IN	MM	IN
29196012	PIVOTING LOW LEAD HIGH LOAD	60	14	9/16	1500	3310	341	12.0	6.0	3/16	45	1 3/4	112.5	4 7/16
29196014	PIVOTING LOW LEAD RATCHET	60	10	3/8	250	550	147	5.2	5.0	3/16	35	1 3/8	105.5	4 5/32
29196013	PIVOTING LOW LEAD RATCHET WITH CLEAT	60	10	3/8	250	550	285	10.1	5.0	3/16	35	1 3/8	105.5	4 5/32

### Lewmar Synchro Snap Shackles



29925040



29926040



29927240



29929040

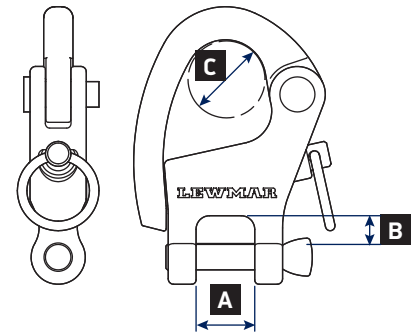

PART NO	FIT BLOCKS	WORKING LOAD LIMIT		BREAKING LOAD		PIN DIA		A		B		C	
		KG	LB	KG	LB	MM	IN	MM	IN	MM	IN	MM	IN
29925040	50 SYNCHRO / 30 & 40 CONTROL SINGLE / DOUBLE	450	990	900	1980	4	1/8	9.0	3/8	4.5	3/16	12	1/2
29926040	60 SYNCHRO / 50 HTX / 30 CONTROL TRIPLE	800	1760	1600	3520	5	3/16	12.0	1/2	6.0	1/4	14	9/16
29927240	72 SYNCHRO / 60 HTX / 40 CONTROL TRIPLE	1100	2420	2200	4840	6	1/4	13.0	1/2	6.5	1/4	18	11/16
29929040	90 SYNCHRO / 72 HTX	2000	4400	4000	8800	9.5	3/8	17.5	11/16	7.5	5/16	22	7/8

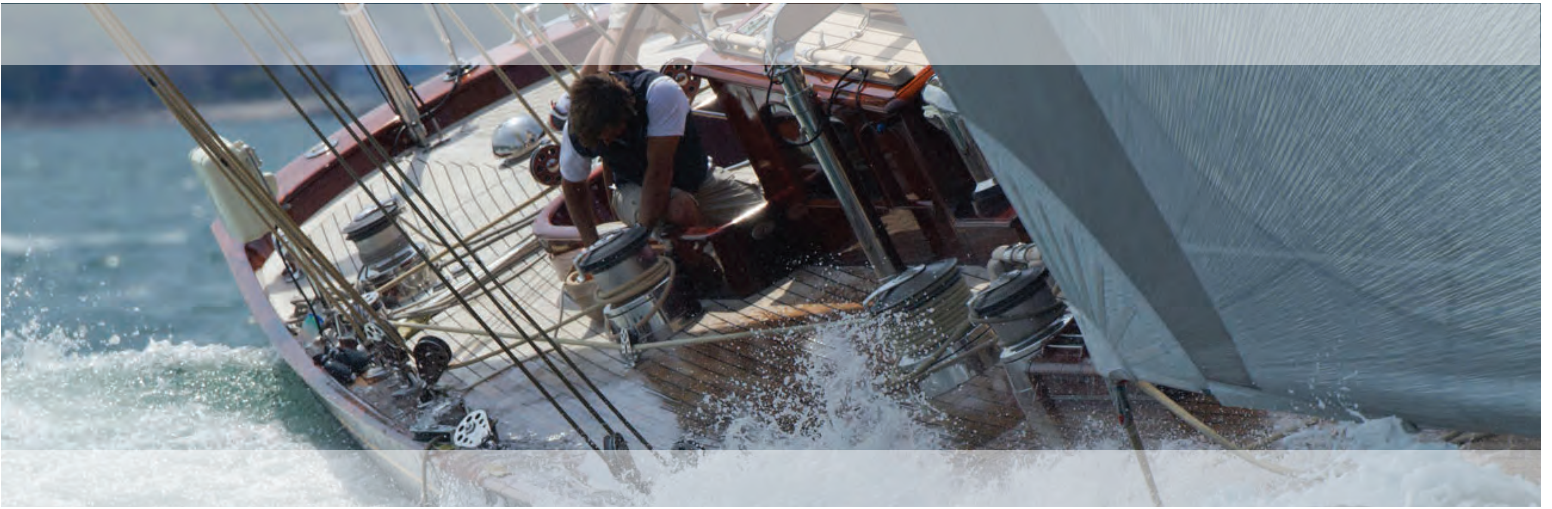

## Custom Blocks

With a wide range of experience across both the race boat and superyacht sectors, Lewmar can offer custom blocks for any situation. Over 70 years of practical knowledge, combined with the latest FEA techniques enables us to optimise each block for its intended application.

Structural loads found in the head of the block are routed through the side cheeks while non-load bearing material is sculpted out. Our team designs and specifies each block to the project's bespoke requirements with typical finishes including highly polished stainless steel, blasted aluminium, titanium or wood.

Lewmar hardware was used aboard Gypsy Moth IV's circumnavigation and has been used to win numerous America's Cups. In recent years, much of our custom block development has been focused on the stunning J-Class fleet. These beautiful classics demand the optimum combination of performance, reliability and style, and are the ultimate proving ground for our current range of custom blocks.

With all the blocks assembled and tested in our Havant, UK facility, our engineering team is able to quickly implement any lessons learnt from testing.



## 8. Hardware



### Soft Loop Blocks

Reaching new standards of innovation, Lewmar-Equiplite® Soft Loop Blocks are designed to be mobile, lightweight and robust with a highly flexible range of uses.

The Soft Loop Blocks feature a continuous rope loop, removable for easy and quick attachment. Ultra-lightweight alloy and carbon fibre construction ensures that the strength-to-weight ratio is unequalled in modern hardware. Combined with our specially designed range of lightweight cars, the Soft Loop Blocks are a formidable component in race systems.

The Soft Loop Blocks are a true performance product, designed for high-level sail handling.

- High-strength alloy and carbon construction
- Detachable rope loop provides incredible flexibility
- Velcro retention strap and shaped side plates prevent accidental release
- Low-friction carbon bearing provides high working loads and performance under pressure
- Disassembles for easy maintenance
- Up to 75% weight saving over traditional systems

### Core Block

The central platform of the Soft Loop Block range, the Core Block is a highly versatile component in a wide variety of applications.

- Central carbon bearing provides very little friction and unparalleled load efficiency
- Continuous fibre loop provides strength and flexibility
- Advanced materials reduce weight



PART NO	SHEAVE Ømm	WORKING LOAD LIMIT		WEIGHT	
		KG	LB	G	OZ
29940487	48	4000	8818	160	5.6
29940707	70	8500	18740	460	16.2
29941207	120	15000	33070	1695	59.8
29395000	135	20000	44100	1950	68.8



## In-Hauler

Developed specifically for barber hauler applications, the In-Hauler packages the principles of the Core Block into a refined, purpose-driven component.

- Ultimately simple design reduces weight and enhances utility
- Designed for use with barber haulers/tweakers
- Ease of use enables quick changes of sheeting configurations

PART NO	SHEAVE Ømm	WORKING LOAD LIMIT		WEIGHT	
		KG	LB	G	OZ
29941408IF	16	2000	4410	42	1.5
29942010IF	30	8000	17640	280	9.9
29943012IF	35	12000	26460	350	12.3



## Core Block Cars

To maximise the weight-saving gains of the Core Blocks, Lewmar have designed specialised genoa and mainsheet cars to work in harmony with the loop blocks.

- Machined from extrusion for optimum strength-to-weight ratio
- Control ends accept dead end or control blocks
- Double ball race provides innovative low friction design
- Available in various configurations for genoa and mainsheet - contact your Lewmar representative for more information
- Designed to be mounted on NTR track

PART NO	SIZE	WORKING LOAD LIMIT		LENGTH		WIDTH		WEIGHT	
		KG	LB	MM	IN	MM	IN	G	OZ
29331153BK	1	2500	5510	150	5.9	66	2.6	288	10.2
29332259BK	2	8000	17640	256	10.1	80	3.1	1662	58.6



# 8. Hardware

## Pad Eyes

Lewmar pad-eyes are designed for leisure marine use and for fixing blocks or similar equipment to the deck.

Their performance depends heavily on the specific application and suitability of installation.

Care must be taken during installation that the pad eye is suitably aligned to the expected load.

### Alignment

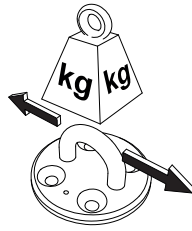

The load direction should be as close to perpendicular with the base as possible. This will maximise the working load of the pad eye.

In addition, the load should be as close to parallel with the bail as possible.

For more information on the deflection effect on force applied refer to the product manuals.



29904060



29192105



29904054



29904040



29904041



29165066



29197266

### Working Load Limit (WLL) Zones

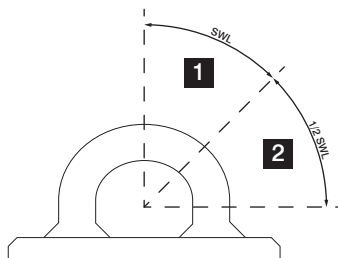

### Dimension diagram

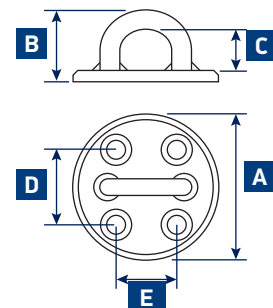

### Pad Eye Specifications

PART NO	DESCRIPTION	WLL ZONE 1		WLL ZONE 2		WEIGHT		BAR DIA		A		B		C		D		E		FIXINGS NOT SUPPLIED	
		KG	LB	KG	LB	G	OZ	MM	IN	MM	IN	MM	IN	MM	IN	MM	IN	MM	IN	MM	IN
29904060	60/80MM PAD EYE	3200	7055	1600	3527	154	5.4	10.0	3/8	66	2 19/32	33	1 19/64	18	23/32	34	1 11/32	28	1 3/32	4XM8	4X 5/16
29192105	105MM PAD EYE	5000	11023	2500	5512	435	15.3	12.7	1/2	98	3 27/32	48	1 57/64	28	13/32	50	2 31/32	42	1 21/32	4XM12	4X 7/16
29904054	130MM PAD EYE	7500	16535	3750	8267	787	27.8	15.8	5/8	115	4 17/32	58	2 5/16	34	15/16	60	2 11/32	48	1 7/8	4XM12	4X 7/16
29165066	SMALL CAST PAD EYE	2500	5511	1250	2756	104	3.7	8.0	5/16	58	2 9/32	27	1 1/16	14	9/16	40	1 37/64	40	1 37/64	4XM6	4X 1/4
29197266	MEDIUM CAST PAD EYE	4500	9921	2250	4960	212	7.5	10.0	3/8	73	2 7/8	35	1 3/8	17	43/64	50	1 31/32	50	1 31/32	4XM8	4X 5/16
29904040	DIAMOND PAD EYE	1135	2502	567	1250	45	1.6	6.0	7/32	38	1 1/2	24	15/16	14	9/16	23	15/16	46	1 13/16	4XM5	4X 3/16
29904041	SQUARE PAD EYE	3180	7011	1590	3505	227	8.0	9.0	5/16	70	2 3/4	37	1 57/64	21	7/8	38	1 1/2	38	1 1/2	4XM8	4X 5/16



## Traveller Systems



### Page 324 Ocean Size 0

- Ideal for cruising yachts up to 8.5 m (28ft)
- Internal control sheave prevents snagging
- Proven performance
- Ocean Car can be adapted to run on curved track



### Page 326 NTR Size 1, 2 & 3

- Popular choice for cruising and racing yachts
- Modular system suits any configuration
- Compatible with Ocean range track
- Larger sheaves results in efficient rope handling



### Page 337 HTX Size 1 & 2

- Ideal for cruiser/racer yachts
- Complements HTX Block Range
- Unique triple ball race for reduced friction
- Minimal parts enhance performance and reliability
- Captive balls ensure easy maintenance



### Page 342 T-Track

- Specialised genoa systems
- Recently restyled to enhance strength and performance
- Available in 25mm through to 65mm
- Choice of wide range of end stops



### Page 345 Size 4 track and cars

- High-load control line sheaves
- Torlon balls running in fully machined ball races
- Machined weight reducing slots
- End stops fixed through deck and track



### Page 346 Custom/Racing

- Custom hardware for yachts up to 67m (220ft)
- Ideal for high-performance racing yachts
- Features patented double ball race
- Carries high load with low friction
- Tailored to specific applications
- Choice of finishes to suit individual requirements



### Page 348 Overside Working System

- Designed to conform to CE EN 975
- Range of options available
- Based on proven technology

# 8. Hardware

## Traveller Systems – Selection Guide

This selection guide is designed to be used as a quick reference only. For more detailed product information visit [www.lewmar.com](http://www.lewmar.com). Calculations are based on the average modern cruising yacht. Sail area, different rigs, heavy or light displacement, multihull or monohull, are all factors which affect a yacht's specifications. Loadings should be obtained from the designer and matched to the safe working load of the hardware. Please contact your Lewmar agent if you have any questions regarding the correct hardware for your boat.

### Cars Selection Guide

APPLICATION & SHEETING POSITION	SIZE	TOWING PURCHASE (MAXIMUM AVAILABLE PURCHASE)	M FT	7.3 24	8.5 28	10.3 34	11.5 38	13.4 44	14.6 48	16.4 54	18.2 60	21.3 70
GENOA	0	2:1		█								
END BOOM MAINSHEET	0	2:1		█								
MID BOOM OR MULTIHULL	0	2:1		█								
GENOA	1	4:1 OR 2:1 TO WINCH			█							
END BOOM MAINSHEET	1	4:1			█							
MID BOOM OR MULTIHULL	1	4:1		█								
GENOA	2	4:1 OR 2:1 TO WINCH				█						
END BOOM MAINSHEET	2	5:1				█						
MID BOOM OR MULTIHULL	2	5:1		█								
GENOA	3	5:1 OR 2:1 TO WINCH					█					
END BOOM MAINSHEET	3	5:1 OR 2:1 TO WINCH					█					
MID BOOM OR MULTIHULL	3	5:1 OR 2:1 TO WINCH					█					



© 2013 Oyster Marine

# Ocean/NTR Tracks

## Beam Track

Beam track is used when spanning cockpits and across companion way hatches. Three fixing bolts should always be used either side of the span and washers fitted under the head of the bolt and between track and deck. Some beam track can only use metric fasteners

Made of Aluminium 6082T6 extrusion.

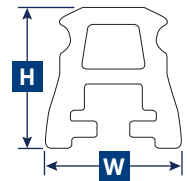

## Sliding Bolt Track

Sliding bolt track has a smooth clean profile with no visible fixings and can be retro-fitted using original bolt holes – no need to worry about old track pattern holes matching up with a new track. The track is designed to permit a washer to fit on each bolt between the track and deck to ensure a secure seal.

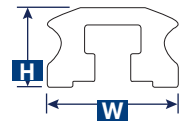

## Drilled Plunger Track

Commonly used and particularly useful where through deck fixing is not possible, such as in double-skinned boats, where fixing bolts are threaded into a plate in the deck.

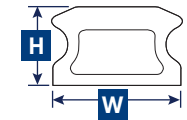

## Ocean/NTR Track Specifications and Fixing Details

PART NO	DESCRIPTION	TRACK SIZE	LENGTH		H HEIGHT		W WIDTH		WEIGHT (per metre)		MAX SPAN BETWEEN FIXINGS / CENTRE HOLE DIM		FIXINGS	
			M	FT	MM	IN	MM	IN	G	OZ	MM	IN	METRIC	IMPERIAL
29160315BK	BEAM TRACK	0	1.5	4'11"	24.7	0.97	24	0.44	954	33.65	400	16	HEX HD M6	1/4"
29162315BK	BEAM TRACK	2	1.5	4'11"	35	1.38	35	1.38	1560	54.91	800	31 1/2	HEX HD M10	-
29162320BK			2	6'7"										
29163315BK	BEAM TRACK	3	1.5	4'11"	55	2.16	50	1.97	3640	128.13	900	35 7/16	HEX HD M12	-
29163320BK			2	6'7"										
29163330BK			3	9'10"										
29161510BK	HD BEAM TRACK	1	1	3'3"	42	1.75	32	1.25	1770	62.4	900	35 7/16	HEX HD M8	5/16"
29161515BK			1.5	4'11"										
29161520BK	HD BEAM TRACK	2	2	6'7"	51	2	51	2	3000	105.82	900	35 7/16	HEX HD M10	3/8"
29162515BK			1.5	4'11"										
29162520BK	2	2	6'7"											
29162115BK	SLIDING BOLT TRACK	2	1.5	4'11"	18	0.71	30	1.18	839	29.56	800	31 1/2	HEX HD M8	5/16"
29162120BK			2	6'7"										
29162130BK			3	9'10"										
29160405BK	DRILLED PLUNGER TRACK	0	0.5	1'8"	11.0	0.43	19	0.75	342	12.06	80	3.1	CSK HD M5	-
29160410BK			1.0	3'3"										
29160415BK			1.5	4'11"										
29161415BK	DRILLED PLUNGER TRACK	1	1.526	5'	13	0.5	23	0.9	530	18.65	100	3 15/16	HEX HD M6	1/4"
29161420BK			2.026	6'8"										
29161430BK			3.026	9'11"										
29162415BK	DRILLED PLUNGER TRACK	2	1.532	5'	15	0.56	30	1.18	764	26.95	100	3 15/16	HEX HD M8	5/16"
29162420BK			2.032	6'3"										
29162430BK			3.032	10'										
29163615BK	DRILLED PLUNGER TRACK	3	1.548	5'1"	21	0.84	35	1.38	968	33.88	100	3 15/16	HEX HD M10	3/8"
29163620BK			2.048	6'9"										
29163630BK			3.048	10'1"										

## 8. Hardware



### Size 0 Ocean Cars

Despite being the smallest range Lewmar produce, Size 0 Ocean hardware is strong, durable and efficient, providing excellent performance and reliability.

- For boats up to 8.5m/28ft.
- Use 50mm/60mm blocks.
- Suitable for 6mm (1/4") control line.

### Short Car with Delrin Balls & Shackle



PART NO	WORKING LOAD LIMIT		LENGTH		WIDTH		WEIGHT	
	KG	LB	MM	IN	MM	IN	G	OZ
29020701BK	200	440	71	2.79	51	2	142	5.59

### Short Car with Delrin Balls, Loop & Single Sheaves



PART NO	WORKING LOAD LIMIT		LENGTH		WIDTH		WEIGHT	
	KG	LB	MM	IN	MM	IN	G	OZ
29330105BK	200	440	73	2.87	51	2	150	6

### Car with Delrin Balls, Shackle & Single Sheaves



PART NO	WORKING LOAD LIMIT		LENGTH		WIDTH		WEIGHT	
	KG	LB	MM	IN	MM	IN	G	OZ
29030100BK	450	990	123	4.83	51	2	210	7.39

### Car with Delrin Balls, Pivoting Loop & Single Sheaves



PART NO	WORKING LOAD LIMIT		LENGTH		WIDTH		WEIGHT	
	KG	LB	MM	IN	MM	IN	G	OZ
29330107BK	450	990	124	4.88	51	2	250	8.5

### Car with Slide Rods, Shackle & Plunger



PART NO	WORKING LOAD LIMIT		LENGTH		WIDTH		WEIGHT	
	KG	LB	MM	IN	MM	IN	G	OZ
29030600BK	450	990	123	4.83	51	2	225	7.92

### Genoa Car with Slide Rods & Plunger



PART NO	WORKING LOAD LIMIT		LENGTH		WIDTH		WEIGHT	
	KG	LB	MM	IN	MM	IN	G	OZ
29040600BK	600	1325	123	4.83	51	2	427	15.03

### Genoa Car with Delrin Balls & Single Sheave



PART NO	WORKING LOAD LIMIT		LENGTH		WIDTH		WEIGHT	
	KG	LB	MM	IN	MM	IN	G	OZ
29040100BK	600	1325	123	4.83	51	2	427	15.03

## Size 0 Ocean End Stops

### Control Line End Stop with Single Sheave



PART NO	WORKING LOAD LIMIT		LENGTH		WIDTH		WEIGHT	
	KG	LB	MM	IN	MM	IN	G	OZ
29170030BK	200	440	58	2.3	51	2	78	2.75

### Control Line End Stop with Sheave, Becket & Cam



PART NO	WORKING LOAD LIMIT		LENGTH		WIDTH		WEIGHT	
	KG	LB	MM	IN	MM	IN	G	OZ
29170033BK	200	440	65	2.3	51	2	397	13.97

### Simple Track End



PART NO	WEIGHT	
	G	OZ
29170040BK	10	35

## Size 0 Ocean Traveller Kit - 2:1 Purchase System

Lewmar makes selecting your mainsheet system simple - with complete Mainsheet System Kits. Lewmar's Size 0 Ocean Mainsheet System is a complete kit made specifically for yachts up to 28 feet (8.5m).

PART NO	DESCRIPTION
29060152BK	SIZE 0 OCEAN TRAVELLER SYSTEM
COMPRISES:	
29030100BK	1 X MAINSHEET CAR
29170040BK	2 X SIMPLE END STOP
29160112	1 X 1.2M SLIDING BOLT TRACK
29171010	1 X SIZE 1 DEAD EYE
29104100BK	2 X SMALL COMPOSITE CLEAT
29904104	2 X SMALL CAM FAIRLEAD

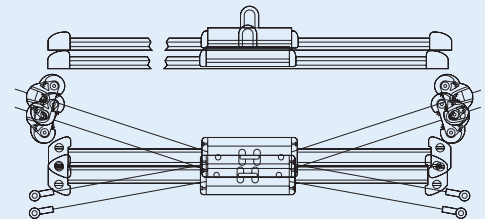

BOAT SIZE	UP TO 8.5M	UP TO 28FT
MAX MAINSAIL AREA (END BOOM):	16M <sup>2</sup>	170FT <sup>2</sup>
MAX MAINSAIL AREA (MID BOOM):	12M <sup>2</sup>	130FT <sup>2</sup>
SAFE WORKING LOAD:	400KG	990LBS

## 8. Hardware



### NTR Cars Size 1 - 2 and 3

The NTR range is the foundation of Lewmar's traveller systems. Found on production yachts across the world, NTR is reliable, seaworthy and designed to perform.

A modular design, NTR cars can be built from components into any configuration, with simple maintenance and servicing. This flexible platform means that every sailor's needs and preferences can be catered for without expensive alterations. Backwards compatibility with our Ocean range ensures the longevity of existing and new systems.

- Popular choice for cruising and racing yachts
- Modular system suits any configuration
- Compatible with Ocean Range track
- Larger sheaves result in efficient rope handling

NTR cars are available with two friction-reducing systems:

#### Torlon Balls (TB)

- Continuous ball race
- High-strength Torlon ensures optimum performance and load management
- Innovative arrangement provides car movement at a range of load angles
- Replacement balls available

#### Slide Rods (SR)

- Simpler, fixed system
- Rods are easy to maintain and replace
- Suitable for more static applications where movement is less vital
- Durable materials





## NTR Mainsheet Traveller Systems

Traveller kits are made up of all the necessary components to assemble a standard system. Each one comes with Lewmar's sliding bolt track, which allow you to retrofit the new track to your deck using the original bolt holes.



### Size 1 Mainsheet System

In the Size 1 kit, you'll find all the components necessary to assemble a standard system.

- For boats up to 11m (36ft)
- Suitable for 8mm (5/16") control line

### Size 2 Mainsheet System

Like the size 1 system, the Size 2 Mainsheet system comes with everything you need for a complete standard system, including the sliding bolt track.

- For boats up to 15m (49ft)
- Suitable for 10mm (3/8") control line

### Size 1&2 Traveller Kit 4:1 Purchase System

	SIZE 1	SIZE 2
TRAVELLER SYSTEM	29461354BK	29462354BK
COMPRISES:		
1 X MAINSHEET CAR SHACKLE WITH DOUBLE CONTROL LINE SHEAVES, CLEATS & BECKETS	29431916BK	29432916BK
2 X END STOP WITH DOUBLE CONTROL LINE SHEAVES	29471032BK	29472032BK
1 X SLIDING BOLT TRACK	29161115BK	29162118BK
TRACK LENGTH	1.5M	1.8M

TRACK SIZE	SIZE 1	SIZE 2
BOAT SIZE	UP TO 11M (36FT)	UP TO 14.6M (48FT)
MAX. MAINSAIL AREA:		
END BOOM:	34M <sup>2</sup> (366FT <sup>2</sup> )	46M <sup>2</sup> (495FT <sup>2</sup> )
MID BOOM:	21M <sup>2</sup> (226FT <sup>2</sup> )	38M <sup>2</sup> (410FT <sup>2</sup> )
SAFE WORKING LOAD:	900KG (1980 LB)	1000KG (2000 LB)

# 8. Hardware

NTR Cars Size 1 - 2 and 3

## Size 1 Upstand Cup Detail

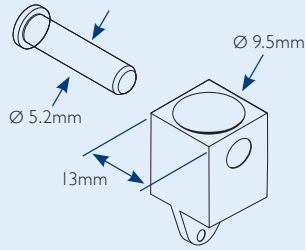

Size 1 upstand fits the following blocks:

- 60 synchro blocks
- 50 HTX blocks
- Racing Blocks (See block dims)
- HLRacing Blocks (See block dims)

## Size 2 Upstand Cup Detail

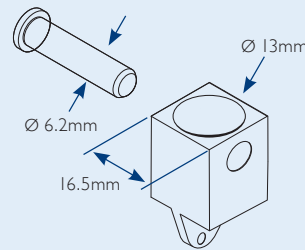

Size 2 upstand fits the following blocks:

- 72 synchro blocks
- 60 HTX blocks
- Racing Blocks (See block dims)
- HLRacing Blocks (See block dims)

## Size 3 Upstand Cup Detail

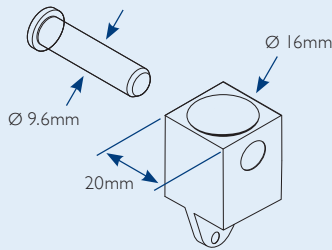

Size 3 upstand fits the following blocks:

- 90 synchro blocks
- 72 HTX blocks
- Racing Blocks (See block dims)
- HLRacing Blocks (See block dims)

## Size 3 HL Upstand Link Detail

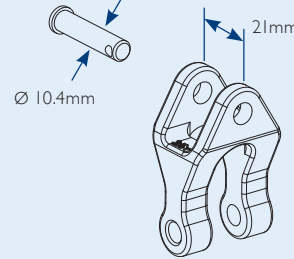

Size 3 upstand fits the following blocks:

- 105 synchro blocks
- 90 HTX blocks
- Racing Blocks (See block dims)
- HLRacing Blocks (See block dims)

## NTR Torklon Ball (TB) Mainsheet Cars Size 1, 2 and 3

### TB Short Car with Shackle



PART NO	SIZE	WORKING LOAD LIMIT		LENGTH		WIDTH		WEIGHT	
		KG	LB	MM	IN	MM	IN	G	OZ
29421300BK	1	600	1329	107	4 3/16	71	2 3/4	228	8.00
29422300BK	2	1100	2420	140	5 1/2	92	3 5/8	386	13.6
29423301BK	3	2000	4400	150	5 15/16	88	3 1/2	680	24.0

### TB Short Car with Upstand



PART NO	SIZE	WORKING LOAD LIMIT		LENGTH		WIDTH		WEIGHT	
		KG	LB	MM	IN	MM	IN	G	OZ
29421400BK	1	600	1329	107	4 3/16	71	2 3/4	241	8.50
29422400BK	2	1100	2420	140	5 1/2	92	3 5/8	397	14
29423400BK	3	2000	4400	150	5 15/16	88	3 1/2	781	27.3

### TB Car with Shackle



PART NO	SIZE	WORKING LOAD LIMIT		LENGTH		WIDTH		WEIGHT	
		KG	LB	MM	IN	MM	IN	G	OZ
29431300BK	1	900	1980	162	6 3/8	71	2 3/4	313	11.0
29432300BK	2	1500	3300	210	8 5/16	92	3 5/8	639	22.5
29433300BK	3	2500	5500	215	8 1/2	88	3 1/2	924	32.3

### TB Car with Upstand



\* 29432420 fitted with size 3 upstand

PART NO	SIZE	WORKING LOAD LIMIT		LENGTH		WIDTH		WEIGHT	
		KG	LB	MM	IN	MM	IN	G	OZ
29431400BK	1	900	1980	162	6 3/8	71	2 3/4	364	12.8
29432400BK	2	1500	3300	210	8 5/16	92	3 5/8	767	27
29432420BK*	2*	2000	4400	210	8 5/16	92	3 5/8	839	33
29433400BK	3	2500	5500	215	8 1/2	88	3 1/2	743	26.0



### NTR Torlon Ball (TB) Mainsheet Cars Size 1, 2 and 3

#### TB Car with Shackle and Single Control Line Sheaves



PART NO	SIZE	WORKING LOAD LIMIT		LENGTH		WIDTH		WEIGHT	
		KG	LB	MM	IN	MM	IN	G	OZ
29431311BK	1	900	1980	162	6 3/8	71	2 3/4	374	13.2
29432311BK	2	1500	3300	210	8 5/16	92	3 5/8	747	26.3

#### TB Car with Upstand and Single Control Line Sheaves



PART NO	SIZE	WORKING LOAD LIMIT		LENGTH		WIDTH		WEIGHT	
		KG	LB	MM	IN	MM	IN	G	OZ
29431411BK	1	900	1980	162	6 3/8	71	2 3/4	421	14.8
29432411BK	2	1500	3300	210	8 5/16	92	3 5/8	875	30.9
29433602BK	3*	3500	7700	270	10 5/8	88	3 1/2	1595	55.8

#### TB Car with Shackle, Single CL Sheaves & Becket



PART NO	SIZE	WORKING LOAD LIMIT		LENGTH		WIDTH		WEIGHT	
		KG	LB	MM	IN	MM	IN	G	OZ
29431315BK	1	900	1980	162	6 3/8	71	2 3/4	378	13.2
29432315BK	2	1500	3300	210	8 5/16	92	3 5/8	867	34.1

#### TB Car with Upstand, Single CL Sheaves & Becket



PART NO	SIZE	WORKING LOAD LIMIT		LENGTH		WIDTH		WEIGHT	
		KG	LB	MM	IN	MM	IN	G	OZ
29431415BK	1	900	1980	162	6 3/8	71	2 3/4	472	16.6
29432415BK	2	1500	3300	210	8 5/16	92	3 5/8	993	35

#### TB Car with Shackle and Double Control Line Sheaves



\* 29432372BK fitted with double ball bearing control line sheaves

PART NO	SIZE	WORKING LOAD LIMIT		LENGTH		WIDTH		WEIGHT	
		KG	LB	MM	IN	MM	IN	G	OZ
29431312BK	1	900	1980	162	6 3/8	71	2 3/4	435	15.3
29432312BK	2	1500	3300	210	8 5/16	92	3 5/8	871	30.7
29432372BK	2*	1500	3300	210	8 5/16	92	3 5/8	880	34.6
29433314BK	3	2500	5500	215	8 1/2	88	3 1/2	993	34.8

#### TB Car with Upstand and Double Control Line Sheaves



\* 29431712BK fitted with size 2 upstand  
 \* 29432424BK fitted with size 3 upstand

\* 29433604BK fitted with size 3 HL upstand

PART NO	SIZE	WORKING LOAD LIMIT		LENGTH		WIDTH		WEIGHT	
		KG	LB	MM	IN	MM	IN	G	OZ
29431412BK	1	900	1980	162	6 3/8	71	2 3/4	486	17.1
29431712BK	1*	900	1980	162	6 3/8	71	2 3/4	486	17.1
29432412BK	2	1500	3300	210	8 5/16	92	3 5/8	997	35.1
29432424BK	2*	2000	4400	210	8 5/16	92	3 5/8	1050	37
29433414BK	3	2500	5500	215	8 1/2	88	3 1/2	1200	42
29433604BK	3*	3500	7700	270	10 5/8	88	3 1/2	1610	56.8

# 8. Hardware

## NTR Torlon Ball (TB) Mainsheet Cars Size 1, 2 and 3

### TB Car with Shackle, Double CL Sheaves & Becket



PART NO	SIZE	WORKING LOAD LIMIT		LENGTH		WIDTH		WEIGHT	
		KG	LB	MM	IN	MM	IN	G	OZ
29431316BK	1	900	1980	162	6 3/8	71	2 3/4	390	13.7
29432316BK	2	1500	3300	210	8 5/16	92	3 5/8	991	39

### TB Car with Upstand, Double CL Sheaves & Becket



PART NO	SIZE	WORKING LOAD LIMIT		LENGTH		WIDTH		WEIGHT	
		KG	LB	MM	IN	MM	IN	G	OZ
29431416BK	1	900	1980	162	6 3/8	71	2 3/4	540	19.0
29432416BK	2	1500	3300	210	8 5/16	92	3 5/8	1117	39.4
29433416BK	3	2500	5500	215	8 1/2	88	3 1/2	1790	62.6

### TB Car with Shackle and Plunger



PART NO	SIZE	WORKING LOAD LIMIT		LENGTH		WIDTH		WEIGHT	
		KG	LB	MM	IN	MM	IN	G	OZ
29431337BK	1	900	1980	162	6 3/8	71	2 3/4	364	12.8

### TB Car, 2 x Sz3 Upstand, Double CL Sheaves, Becket & Cam



\* 29432836BK fitted with size 3 upstand

PART NO	SIZE	WORKING LOAD LIMIT		LENGTH		WIDTH		WEIGHT	
		KG	LB	MM	IN	MM	IN	G	OZ
29432836BK	2*	2800	6160	307	12 1/16	120	4 3/4	2173	85.5

\* Car WWL, cleat WLL shown on p346

### TB Car with Shackle, Double CL Sheaves & Cam (4:1)



PART NO	SIZE	WORKING LOAD LIMIT		LENGTH		WIDTH		WEIGHT	
		KG	LB	MM	IN	MM	IN	G	OZ
29431834BK	1	900	1980	162	6 3/8	97	3 3/4		

\* Car WWL, cleat WLL shown on p346

### TB Car with Upstand, Double CL Sheaves & Cam (4:1)



PART NO	SIZE	WORKING LOAD LIMIT		LENGTH		WIDTH		WEIGHT	
		KG	LB	MM	IN	MM	IN	G	OZ
29431814BK	1	900	1980	162	6 3/8	97	3 3/4	759	26.7
29432814BK	2	1500	3300	210	8 5/16	120	4 3/4	1496	52.7

\* Car WWL, cleat WLL shown on p346

### Radius Cars

Radius cars available upon request for all size 1, 2 and 3.

Please contact your Lewmar representative and specify your track Vertical or Horizontal radius.

Spare Bearings: Torlon Balls for Ocean & NTR Cars

PART NO	DESCRIPTION	WHERE USED	DIAMETER	
			MM	IN
29171021	TORLON BALLS (PER 100)	SZ1 OCEAN AND NTR CARS	6.4	1/4
29172021	TORLON BALLS (PER 100)	SZ2 OCEAN AND NTR CARS	7.8	5/16

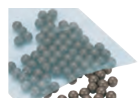

## NTR Torlon Ball (TB) Mainsheet Cars Size 1, 2 and 3

### TB Car with Shackle, Double CL Sheaves, Becket & Cam (5:1)



PART NO	SIZE	WORKING LOAD LIMIT		LENGTH		WIDTH		WEIGHT	
		KG	LB	MM	IN	MM	IN	G	OZ
29431916BK	1	900	1980	162	6 3/8	97	3 3/4	799	28.2
29432916BK	2	1500	3300	210	8 5/16	120	4 3/4	1730	68.1

\* Car WWL, cleat WLL shown on p346

### TB Car with Upstand, Double CL Sheaves, Becket & Cam (5:1)



\* 29432838BK fitted with size 3 upstand

PART NO	SIZE	WORKING LOAD LIMIT		LENGTH		WIDTH		WEIGHT	
		KG	LB	MM	IN	MM	IN	G	OZ
29432816BK	2	1500	3300	210	8 5/16	120	4 3/4	1610	56.7
29432838BK	2*	3500	7700	307	12 1/16	120	4 3/4	1786	70.3

\* Car WWL, cleat WLL shown on p346

### TB Car Long, 2x Upstand, Double CL Sheaves



\* 29432832BK fitted with size 3 upstand

PART NO	SIZE	WORKING LOAD LIMIT		LENGTH		WIDTH		WEIGHT	
		KG	LB	MM	IN	MM	IN	G	OZ
29432822BK	2	1800	3960	307	12 1/16	92	3 5/8	1460	51.5
29432832BK	2*	2800	6160	307	12 1/16	92	3 5/8	1560	55
29433832BK	3	3500	7700	270	10 5/8	88	3 1/2	1810	63.8

### TB Car Long, 3x Upstand, Double CL Sheaves



\* 29432833BK fitted with size 3 upstand

PART NO	SIZE	WORKING LOAD LIMIT		LENGTH		WIDTH		WEIGHT	
		KG	LB	MM	IN	MM	IN	G	OZ
29432823BK	2	3000	6600	307	12 1/16	92	3 5/8	1460	51.5
29432833BK	2*	3500	7700	307	12 1/16	92	3 5/8	1560	55
29433833BK	3	4000	8800	300	11 3/4	88	3 1/2	2190	77.2

## NTR Torlon Ball (TB) Genoa Cars Size 1, 2 and 3

### TB Short Genoa Car with Tow Point



PART NO	SIZE	WORKING LOAD LIMIT		LENGTH		WIDTH		WEIGHT	
		KG	LB	MM	IN	MM	IN	G	OZ
29421366BK	1*	600	1320	107	4 3/4	71	2 3/4	521	18.3

\* Limiter supplied non-assembled for a port or starboard application

### TB Genoa Car with Becket



PART NO	SIZE	WORKING LOAD LIMIT		LENGTH		WIDTH		WEIGHT	
		KG	LB	MM	IN	MM	IN	G	OZ
29441301BK	1*	900	1980	162	6 3/8	71	2 3/4	577	20.3
29442301BK	2*	1800	3960	210	8 5/16	120	4 3/4	1327	46.8

\* Limiter supplied non-assembled for a port or starboard application

## 8. Hardware

### NTR Torlon Ball (TB) Genoa Cars Size 1, 2 and 3

#### TB Genoa Car with Single Control Line Sheave



PART NO	SIZE	WORKING LOAD LIMIT		LENGTH		WIDTH		WEIGHT	
		KG	LB	MM	IN	MM	IN	G	OZ
29441311BK	1*								
29441321BK	1 PORT	900	1980	162	6 3/8	71	2 3/4	560	19.8
29441331BK	1 STBD								
29442311BK	2*								
29442321BK	2 PORT	1800	3960	210	8 5/16	120	4 3/4	1330	46.9
29442331BK	2 STBD								
29443311BK	3	3500	7700	215	8 1/2	88	3 1/2	1565	54.8
29443611BK	3	5000	11000	320	12 5/8	88	3 1/2		

\* Limiter supplied non-assembled for a port or starboard application

#### TB Genoa Car with Double Control Line Sheaves



PART NO	SIZE	WORKING LOAD LIMIT		LENGTH		WIDTH		WEIGHT	
		KG	LB	MM	IN	MM	IN	G	OZ
29441312BK	1*								
29441322BK	1 PORT	900	1980	162	6 3/8	71	2 3/4	566	19.9
29441332BK	1 STBD								
29442312BK	2*								
29442322BK	2 PORT	1800	3960	210	8 5/16	120	4 3/4	1354	47.7
29442332BK	2 STBD								

\* Limiter supplied non-assembled for a port or starboard application

#### TB Car Genoa stirrup, single CL sheave and becket



PART NO	SIZE	WORKING LOAD LIMIT		LENGTH		WIDTH		WEIGHT	
		KG	LB	MM	IN	MM	IN	G	OZ
29441345BK	1*	900	1980	162	6 3/8	71	2 3/4	566	19.9
29442345BK	2*	1800	3960	210	8 5/16	120	4 3/4	1359	47.9

\* Limiter supplied non-assembled for a port or starboard application

#### Spare Bearings: Torlon Balls for Ocean & NTR Cars

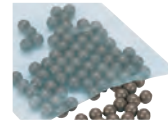

PART NO	DESCRIPTION	WHERE USED	DIAMETER	
			MM	IN
29171021	TORLON BALLS (PER 100)	S21 OCEAN AND NTR CARS	6.4	1/4
29172021	TORLON BALLS (PER 100)	S22 OCEAN AND NTR CARS	7.8	5/16

#### Expert advice

Current Lewmar track is NTR specification.

If retrofitting check your track using the following:

- Size 3 NTR tracks have 12mm Ø plunger holes
- Size 3 Ocean tracks have 9.5mm Ø plunger holes

### NTR Slide Rod (SR) Cars Size 1, 2 and 3

#### SR Car with Shackle



PART NO	SIZE	WORKING LOAD LIMIT		LENGTH		WIDTH		WEIGHT	
		KG	LB	MM	IN	MM	IN	G	OZ
29431500BK	1	1000	2200	162	6 3/8	50	2	230	8.11
29432500BK	2	2000	4400	210	8 5/16	65	2 5/8	559	19.7

#### SR Car with Shackle and Plunger Stop



PART NO	SIZE	WORKING LOAD LIMIT		LENGTH		WIDTH		WEIGHT	
		KG	LB	MM	IN	MM	IN	G	OZ
29441723BK	1	1000	2200	162	6 3/8	50	2	264	9.3
29442723BK	2	2000	4400	210	8 5/16	65	2 5/8	577	19.6

NTR Slide Rod (SR) Cars Size 1, 2 and 3

SR Car with Shackle and Single Control Line Sheaves



PART NO	SIZE	WORKING LOAD LIMIT		LENGTH		WIDTH		WEIGHT	
		KG	LB	MM	IN	MM	IN	G	OZ
29432511BK	2	2000	4400	210	8 5/16	65	2 5/8	667	23.5

SR Car with Shackle and Double Control Line Sheaves



PART NO	SIZE	WORKING LOAD LIMIT		LENGTH		WIDTH		WEIGHT	
		KG	LB	MM	IN	MM	IN	G	OZ
29432512BK	2	2000	4400	210	8 5/16	65	2 5/8	791	27.9

SR Car with Upstand and Double Control Line Sheaves



PART NO	SIZE	WORKING LOAD LIMIT		LENGTH		WIDTH		WEIGHT	
		KG	LB	MM	IN	MM	IN	G	OZ
29442412BK	2	2000	4400	210	8 5/16	65	2 5/8	795	8

SR Genoa Car



PART NO	SIZE	WORKING LOAD LIMIT		LENGTH		WIDTH		WEIGHT	
		KG	LB	MM	IN	MM	IN	G	OZ
29441500BK	1*	1000	2200	162	6 3/8	50	2	480	16.8
29442500BK	2*	1800	3960	194	7 5/8	65	2 5/8	1100	38.8

\* Limiter supplied non-assembled for a port or starboard application

SR Genoa Car with Plunger Stop



PART NO	SIZE / DESCRIPTION	WORKING LOAD LIMIT		LENGTH		WIDTH		WEIGHT	
		KG	LB	MM	IN	MM	IN	G	OZ
294417**BK	1	1000	2200	162	6 3/8	50	2	480	16.8
294427**BK	2	1800	3960	194	7 5/8	65	2 5/8	1201	42.4
29443700BK	3 (NTR TRACK)	3500	7700	180	7 1/16	70	2 13/16	1410	49.4
29443700CBK	3 (OCEAN TRACK)	3500	7700	180	7 1/16	70	2 13/16	1410	49.4
29443702BK	3 (NTR COMPOSITE SHEAVE)	2250	4950	180	7 1/16	70	2 13/16	1079	37.8

\*\* Insert 00 for limiter non-assembled, 20 for port limiter and 30 for starboard limiter

SR Genoa Car with Single Control Line Sheaves



PART NO	SIZE	WORKING LOAD LIMIT		LENGTH		WIDTH		WEIGHT	
		KG	LB	MM	IN	MM	IN	G	OZ
29441513BK	1*	1000	2200	162	6 3/8	50	2	484	17

\* Limiter supplied non-assembled for a port or starboard application

# 8. Hardware

## NTR End Stops Size 1, 2 and 3

Sz1 Impact End Stop



PART NO	WORKING LOAD LIMIT		LENGTH		WIDTH		WEIGHT	
	KG	LB	MM	IN	MM	IN	G	OZ
29905105BK	500	1100	40	1 1/2	46	1 3/4	24	0.8

Sz2 Impact End Stop



PART NO	WORKING LOAD LIMIT		LENGTH		WIDTH		WEIGHT	
	KG	LB	MM	IN	MM	IN	G	OZ
29905200BK	1250	2755	114	4 1/2	80	3 1/8	158	5.6

REQUIRES EXTRA DRILLING IN THE TRACK

Sz3 Impact End Stop



PART NO	WORKING LOAD LIMIT		LENGTH		WIDTH		WEIGHT	
	KG	LB	MM	IN	MM	IN	G	OZ
29473030BK	2200	4840	93	3 11/16	70	2 13/16	247	8.7

Bare End Stop



PART NO	SIZE	WORKING LOAD LIMIT		LENGTH		WIDTH		WEIGHT	
		KG	LB	MM	IN	MM	IN	G	OZ
29471030BK	1	585	1287	47	1 7/8	29	1 1/8	99	3.5
29472030BK	2	750	1650	105	4 1/8	65	2 5/8	238	8.4

Mid Track Stop



PART NO	SIZE	WORKING LOAD LIMIT		LENGTH		WIDTH		WEIGHT	
		KG	LB	MM	IN	MM	IN	G	OZ
29472501BK	2	750	1650	105	4 1/8	65	2 5/8	238	8.4

Mid Track Stop with Single CL Sheave & Becket



PART NO	SIZE	WORKING LOAD LIMIT		LENGTH		WIDTH		WEIGHT	
		KG	LB	MM	IN	MM	IN	G	OZ
29472535BK	2	750	1650	105	4 1/8	65	2 5/8	338	11.9

Friction Stop



PART NO	SIZE	WORKING LOAD LIMIT		LENGTH		WIDTH		WEIGHT	
		KG	LB	MM	IN	MM	IN	G	OZ
29472038BK	2	975	2145	87	3 3/8	65	2 5/8	261	9.2

End Stop with Single CL Sheave



PART NO	SIZE	WORKING LOAD LIMIT		LENGTH		WIDTH		WEIGHT	
		KG	LB	MM	IN	MM	IN	G	OZ
29471031BK	1	585	1287	75	1 45/64	50	2	140	4.9
29472031BK	2	750	1650	105	4 1/8	65	2 5/8	301	10.6

End Stop with Single CL Sheave and Becket



PART NO	SIZE	WORKING LOAD LIMIT		LENGTH		WIDTH		WEIGHT	
		KG	LB	MM	IN	MM	IN	G	OZ
29471035BK	1	585	1287	47	1 55/64	29	1 9/64	165	5.8
29472035BK	2	750	1650	105	4 1/8	65	2 5/8	331	11.7
29473035BK	3	800	1760	93	3 11/16	70	2 13/16	381	13.3
29473135BK	3 (HL)	3000	6600	140	5 1/2	70	2 13/16	537	18.8

## NTR End Stops Size 1, 2 and 3

### End Stop with Double CL Sheaves



PART NO	SIZE	WORKING LOAD LIMIT		LENGTH		WIDTH		WEIGHT	
		KG	LB	MM	IN	MM	IN	G	OZ
29471032BK	1	585	1287	75	1 45/64	50	2	172	6.1
29472032BK	2	750	1650	105	4 1/8	65	2 5/8	363	12.8
29473032BK	3	800	1760	93	3 11/16	70	2 13/16	390	13.7

### End Stop with Double CL Sheaves and Becket



\* Fitted with ball bearing control line sheaves

\*\* Fitted with HDI control line sheaves

PART NO	SIZE	WORKING LOAD LIMIT		LENGTH		WIDTH		WEIGHT	
		KG	LB	MM	IN	MM	IN	G	OZ
29471036BK	1	585	1287	47	1 55/64	29	1 9/64	185	6.5
29472036BK	2	750	1650	105	4 1/8	65	2 5/8	393	13.8
29472076BK	2*	750	1650	105	4 1/8	65	2 5/8	400	14.1
29472616BK	2**	750	1650	105	4 1/8	65	2 5/8	400	14.1
29473036BK	3	800	1760	93	3 11/16	70	2 13/16	460	16.1
29473136BK	3 (HL)	3000	6600	140	5 1/2	70	2 13/16	769	27.1

### End Stop with Double CL Sheaves, Becket & Cam (pair)



PART NO	SIZE	WORKING LOAD LIMIT		LENGTH		WIDTH		WEIGHT	
		KG	LB	MM	IN	MM	IN	G	OZ
29471836BK	1	585	1287	75	2 61/64	78	3 5/64	258	9.1
29472836BK	2	750	1650	105	4 1/8	112	4 5/8	602	21.2

\* End stop WWL, cleat WLL shown on p346

### End Stop Sheet Lead



PART NO	SIZE	WORKING LOAD LIMIT		LENGTH		WIDTH		WEIGHT	
		KG	LB	MM	IN	MM	IN	G	OZ
29441701BK	1	1000	2200	162	6 3/8	50	2	480	16.8
29442701BK	2	1800	3960	194	7 5/8	65	2 5/8	1134	40
29443701BK	3	2000	4400	140	5 1/2	70	2 13/16	885	31

### Plunger Stop



#### \*Size 3 plunger stop:

- If retrofitting check your track:
- 29473037BK fits size 3 NTR tracks (12mm Ø plunger holes)
  - 29473037CBK fits size 3 Ocean tracks (9.5mm Ø plunger holes)

PART NO	SIZE	WORKING LOAD LIMIT		LENGTH		WIDTH		WEIGHT	
		KG	LB	MM	IN	MM	IN	G	OZ
29471037BK	1	650	1430	43	1 11/16	50	2	83	2.9
29472037BK	2	975	2145	87	3 3/8	65	2 5/8	261	9.2
29473037BK	3*	2000	4400	80	3 3/16	70	2 13/16	298	10.4
29473037CBK	3*	2000	4400	80	3 3/16	70	2 13/16	298	10.4

### Track End



PART NO	SIZE	WEIGHT	
		G	OZ
29171040BK	1	22	0.77
29172040BK	2	30	1.1
29173040BK	3	42	1.5

## NTR Car Links

### Short Car Link



PART NO	SIZE
29471063BK	1
29472063BK	2
29473063BK	3

### Car Link with Sz3 Upstand



PART NO	SIZE
29472062BK	2

# 8. Hardware

## NTR Spares and Accessories

Beam Track End Cover (Pair)



PART NO	SIZE	WEIGHT	
		G	OZ
29471041BK	1	12	0.4
29472041BK	2	26	0.9
29473041BK	3	42	1.5

HD Beam Track End Cover (Pair)



PART NO	SIZE	LENGTH		WIDTH		WEIGHT	
		MM	IN	MM	IN	G	OZ
29471042BK	1	13	1/2	50	2	18	0.6
29472042BK	2	22	7/8	65	2 5/8	40	1.4

Single Control Line Sheaves (Pair)



PART NO	SIZE	SHEAVE Ø		WEIGHT	
		MM	IN	G	OZ
29471011BK	1	29	1 1/8	82	2.9
29472011BK	2	63	2 1/2	137	4.8

Double Control Line Sheaves (Pair)



PART NO	SIZE	SHEAVE Ø		WEIGHT	
		MM	IN	G	OZ
29471012BK	1	29	1 1/8	148	5.2
29472012BK	2	63	2 1/2	261	9.2

Double Control Sheaves & Cleats (Pair)



PART NO	SIZE	WORKING LOAD LIMIT		WEIGHT	
		KG	LB	G	OZ
29471018BK	1	180	396	180	6.3
29472018BK	2	180	396	625	22

Cleat Assembly for End Stop (Pair)



PART NO	SIZE	WORKING LOAD LIMIT		WEIGHT	
		KG	LB	G	OZ
29471015BK	1	180	396	123	4.3
29472015BK	2	180	396	368	12.9

Genoa Stirrup Assembly



PART NO	SIZE	WORKING LOAD LIMIT		WIDTH		WEIGHT	
		KG	LB	MM	IN	G	OZ
28003225BK	1	1000	2200	45	1 3/4	227	8
28003226BK	2	1800	3960	60	2 3/8	620	21.9

Upstand Assembly



PART NO	SIZE
29171024	1
29172024	2
29473024	3

Becket Assembly (Pair)



PART NO	SIZE	WEIGHT	
		G	OZ
29471010	1	51	1.7
29472010	2	114	4.2

Slide Rods



PART NO	SIZE
25002920	1
25003438	2
25003969	3

Rubber Buffer Kit



PART NO	SIZE
29171046BK	1
29172046BK	2
29173046BK	3

To fit end stops and slide rod cars



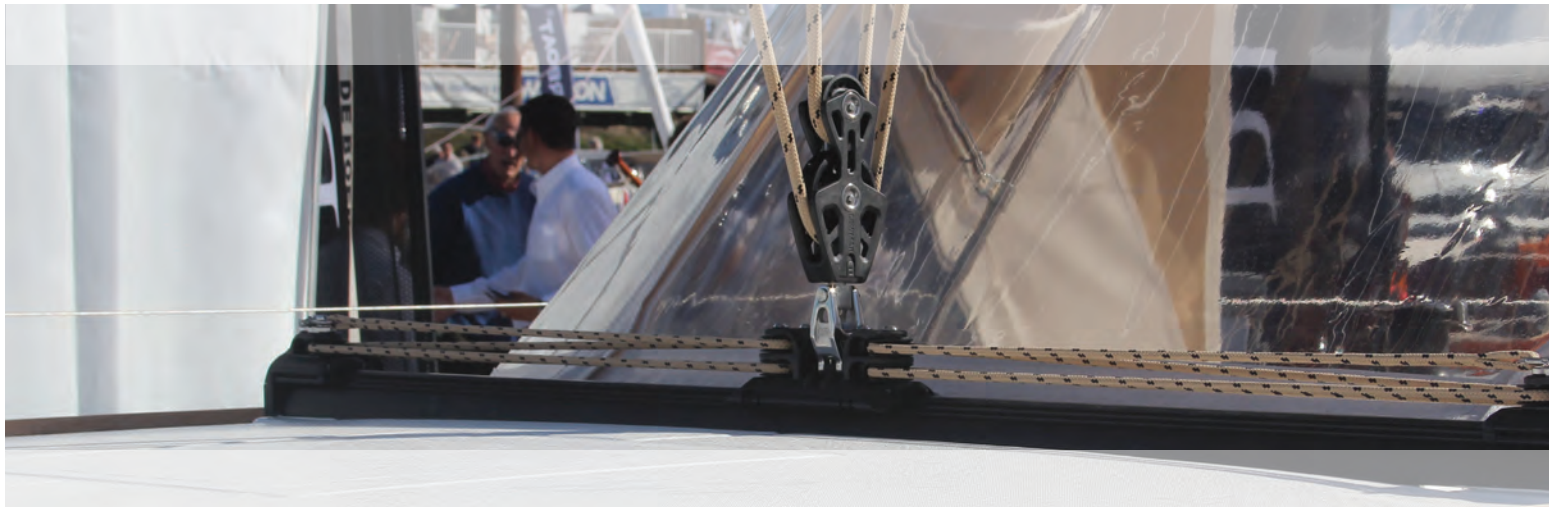

## HTX Size 1 & 2 Cars

Lewmar has developed the HTX Traveller Range to complement the HTX Block Range. This range of travellers has come from many years of design and manufacturing experience and collaboration with boat builders, designers, and sailors. At the core of the HTX Traveller Range is the Captive Ball Traveller. Featuring the neat, stylish retention of the ball bearings within the car, the Captive Ball Traveller is simple to install and easy to remove for cleaning and maintenance without the risk of losing ball bearings.



- Ideal for boats up to 15 metres (49 ft)
- Minimalistic car body made of fewer parts
- Compact, one-piece aluminium body and composite end caps designed with smoother lines
- Available in multiple configurations, including single or double control line sheaves, becket, and cam cleat
- Compatible slide-rod Genoa car with stirrup
- Three individual ball races: the first two allow fast movement of the car under vertical load, and the third allows smooth running of the car under deflection
- Larger balls means more ball surface exposure, increasing overall efficiency
- Ball bearings circulate through an open structure allowing easy cleaning when installed
- Proprietary dowel mechanism provides smooth ball circulation
- Upstand receives shackle or lashed rope, removing need for a becket above the control line sheaves

## 8. Hardware



### HTX Mainsheet Traveller Systems

Traveller kits are made up of all the necessary components to assemble a standard system. Each one comes with Lewmar's sliding bolt track, which allow you to retrofit the new track to your deck using the original bolt holes.



#### Size 1 Mainsheet System

In the Size 1 kit, you'll find all the components necessary to assemble a standard system.

- For boats up to 11m (36ft)
- Suitable for 8mm (5/16") control line

#### Size 2 Mainsheet System

Like the size 1 system, the Size 2 Mainsheet system comes with everything you need for a complete standard system, including the sliding bolt track.

- For boats up to 15m (49ft)
- Suitable for 10mm (3/8") control line

#### Size 1&2 Traveller Kit 4:1 Purchase System

	SIZE 1	SIZE 2
TRAVELLER SYSTEM	29461354BK	29462354BK
COMPRISES:		
1 X MAINSHEET CAR SHACKLE WITH DOUBLE CONTROL LINE SHEAVES, CLEATS & BECKETS	291213315	291223415
2 X END STOP WITH DOUBLE CONTROL LINE SHEAVES	291218806	291228806
1 X SLIDING BOLT TRACK	29181415	29182420
TRACK LENGTH	1.5M	2.0M

## HTX Size 1 & 2 Tracks

### Drilled Plunger Track

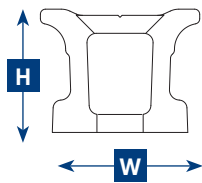

Commonly used and particularly useful where through deck fixing is not possible, such as in double skinned boats, where fixing bolts are trapped into a plate in the deck.

### Beam Track

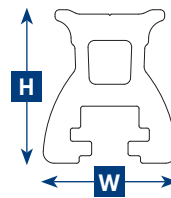

Beam track is used when spanning cockpits and across companion way hatches. Three fixing bolts should always be used either side of the span and washers fitted under the head of the bolt and between track and deck. Some beam track can only use metric fasteners

- Made of Aluminium 6082T6 extrusion

### HTX Track Specifications and Fixing Details

PART NO	DESCRIPTION	TRACK SIZE	ACTUAL LENGTH		HEIGHT		WIDTH		WIDTH (OVERALL)		WEIGHT (per metre)		MAX SPAN BETWEEN FIXINGS / CENTRE HOLE DISTANCE		FIXINGS	
			M	FT	MM	IN	MM	IN			G	OZ	MM	IN	METRIC	IMPERIAL
29181415	DRILLED PLUNGER TRACK	1	1.526	5'	20	0.78	22.0	0.86	25	0.98	658	23.21	100	3 15/16	M6	1/4"
29181420			2.026	6'8"												
29181430			3.026	9'11"												
29182415	DRILLED PLUNGER TRACK	2	1.532	5'	24	0.94	26.4	1.04	31	1.22	933	32.91	100	3 15/16	M8	5/16"
29182420			2.032	6'3"												
29182430			3.032	10'												
29181315	BEAM TRACK	1	1.5	4'11"	31	1.22	27.8	1.09			1092	38.52	700	27 9/16	M10	5/16"
29181320			2.0	6'7"												
29182315	BEAM TRACK	2	1.5	4'11"	40	1.57	35.1	1.38			1697	59.86	800	31 1/2	M12	3/8"
29182320			2.0	6'7"												

### HTX Size 1 & 2 Cars

#### Size 1 Traveller System

For boats up to 11m (36ft)

Suitable for 8mm (5/16") control line

#### Size 2 Traveller System

For boats up to 15m (49ft).

Suitable for 10mm (3/8") control line.

### HTX Size 1 Uprand Cup Detail

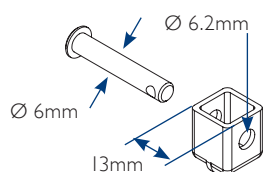

Size 1 upstand fits the following blocks:

- 72 Synchro blocks
- 60 HTX blocks
- 60 Single Racing blocks

### HTX Size 2 Uprand Cup Detail

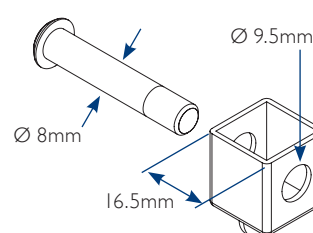

Size 2 upstand fits the following blocks:

- 90 Synchro blocks
- 72 HTX blocks
- 80 Triple Racing blocks

# 8. Hardware

## HTX Size 1 & 2 Torlon Ball (TB) Mainsheet Cars

Mainsheet Car – Dimension Diagram

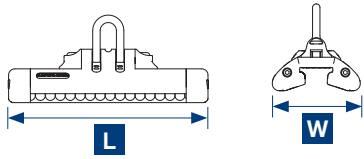

### Size 1 Traveller System

For boats up to 11m (36ft)

Suitable for 8mm (5/16") control line

### Size 2 Traveller System

For boats up to 15m (49ft).

Suitable for 10mm (3/8") control line.

TB Short Car with Shackle



TB Car with Shackle



PART NO	SIZE	WORKING LOAD LIMIT		LENGTH		WIDTH		WEIGHT	
		KG	LB	MM	IN	MM	IN	G	OZ
291222301	2	1500	3300	140	5 1/2	85	3 3/8	525	18.5

PART NO	SIZE	WORKING LOAD LIMIT		LENGTH		WIDTH		WEIGHT	
		KG	LB	MM	IN	MM	IN	G	OZ
291213301	1	1100	2420	160	6 5/16	71	2 13/16	427	15.1
291223301	2	2200	4850	205	8 1/16	85	3 3/8	772	27.2

TB Car with Shackle and Single Control Line Sheaves



TB Car with Shackle and Double Control Line Sheaves



PART NO	SIZE	WORKING LOAD LIMIT		LENGTH		WIDTH		WEIGHT	
		KG	LB	MM	IN	MM	IN	G	OZ
291213305	1	1100	2420	160	6 5/16	71	2 13/16	450	15.9
291223305	2	2200	4850	205	8 1/16	85	3 3/8	880	31.0

PART NO	SIZE	WORKING LOAD LIMIT		LENGTH		WIDTH		WEIGHT	
		KG	LB	MM	IN	MM	IN	G	OZ
291223306	2	2000	4400	205	8 1/16	85	3 3/8	980	34.6

TB Car with Shackle, Single Control Sheaves & Becket



TB Car with Upstand, Single Control Sheaves & Becket



PART NO	SIZE	WORKING LOAD LIMIT		LENGTH		WIDTH		WEIGHT	
		KG	LB	MM	IN	MM	IN	G	OZ
291213308	1	1100	2420	160	6 5/16	71	2 13/16	510	18.0
291223308	2	2200	4850	205	8 1/16	85	3 3/8	1156	40.8

PART NO	SIZE	WORKING LOAD LIMIT		LENGTH		WIDTH		WEIGHT	
		KG	LB	MM	IN	MM	IN	G	OZ
291213408	1	800	1764	160	6 5/16	71	2 13/16	545	19.2
291223408	2	2200	4850	205	8 1/16	85	3 3/8	1310	46.2

**TB Car with Upstand, Double Control Sheaves & Cleat**



PART NO	SIZE	WORKING LOAD LIMIT		LENGTH		WIDTH		WEIGHT	
		KG	LB	MM	IN	MM	IN	G	OZ
291213412	1	800	1600	167	6 9/16	98	3 7/8	780	27.5
291223412	2	2200	4850	225	8 7/8	132	5 3/16	1690	59.6

\* Car WWL, cleat WLL shown on p354

**TB Car with Upstand and Double Control Sheaves**



PART NO	SIZE	WORKING LOAD LIMIT		LENGTH		WIDTH		WEIGHT	
		KG	LB	MM	IN	MM	IN	G	OZ
291213406	1	800	1600	160	6 5/16	71	2 13/16	627	22.1
291223406	2	2200	4850	205	8 1/16	85	3 3/8	1250	44.1

**TB Car with Shackle, Double Control Sheaves, Becket & Cleat**



PART NO	SIZE	WORKING LOAD LIMIT		LENGTH		WIDTH		WEIGHT	
		KG	LB	MM	IN	MM	IN	G	OZ
291213315	1	1100	2420	167	6 9/16	98	3 7/8	750	26.5
291223315	2	2200	4850	225	8 7/8	132	5 3/16	1580	55.7

\* Car WWL, cleat WLL shown on p354

**TB Car with Upstand, Double Control Sheaves, Becket & Cleat**



PART NO	SIZE	WORKING LOAD LIMIT		LENGTH		WIDTH		WEIGHT	
		KG	LB	MM	IN	MM	IN	G	OZ
291223415	2	2000	4400	225	8 7/8	132	5 3/16	1880	66.3

\* Car WWL, cleat WLL shown on p354

**HTX Size 2 Double Upstand Torlon Ball (TB) Mainsheet Cars**

**TB Car with Double Upstand**



PART NO	SIZE	WORKING LOAD LIMIT		LENGTH		WIDTH		WEIGHT	
		KG	LB	MM	IN	MM	IN	G	OZ
291213601	2	2600	5732	305	12	85	3 3/8	1920	67.7

**TB Car with Double Upstand and Double Control Sheaves**



PART NO	SIZE	WORKING LOAD LIMIT		LENGTH		WIDTH		WEIGHT	
		KG	LB	MM	IN	MM	IN	G	OZ
291213606	2	2600	5732	305	12	85	3 3/8	2249	79.3

**HTX Size 1 & 2 Slide Rod (SR) Cars**

**SR Car with Shackle**



PART NO	SIZE	WORKING LOAD LIMIT		LENGTH		WIDTH		WEIGHT	
		KG	LB	MM	IN	MM	IN	G	OZ
291213501	1	1100	2420	160	6 5/16	71	2 13/16	310	10.9
291223501	2	2200	4850	205	8 1/16	85	3 3/8	730	25.8

**SR Car with Shackle and Plunger**



PART NO	SIZE	WORKING LOAD LIMIT		LENGTH		WIDTH		WEIGHT	
		KG	LB	MM	IN	MM	IN	G	OZ
291213537	1	1100	2420	160	6 5/16	71	2 13/16	365	12.9
291223537	2	2200	4850	205	8 1/16	85	3 3/8	790	27.9

# 8. Hardware

## HTX Size 1 & 2 Genoa Cars

### SR Genoa Car with Plunger



PART NO	SIZE	WORKING LOAD LIMIT		LENGTH		WIDTH		WEIGHT	
		KG	LB	MM	IN	MM	IN	G	OZ
291214537	1 PORT	1100	2420	160	6 5/16	71	2 13/16	630	22.2
291215537	1 STBD								
291224537	2 PORT	2200	4850	205	8 1/16	85	3 3/8	1500	52.9
291225537	2 STBD								

### TB Genoa Car with Single Control Line Sheave



PART NO	SIZE	WORKING LOAD LIMIT		LENGTH		WIDTH		WEIGHT	
		KG	LB	MM	IN	MM	IN	G	OZ
291214305	1 PORT	1100	2420	160	6 5/16	71	2 13/16	650	22.9
291215305	1 STBD								
291224305	2 PORT	2200	4850	205	8 1/16	85	3 3/8	1600	56.4
291225305	2 STBD								

### TB Genoa Car with Single Control Line Sheave & Becket



PART NO	SIZE	WORKING LOAD LIMIT		LENGTH		WIDTH		WEIGHT	
		KG	LB	MM	IN	MM	IN	G	OZ
291214308	1 PORT	1100	2420	160	6 5/16	71	2 13/16	650	22.9
291215308	1 STBD								
291224308	2 PORT	2200	4850	205	8 1/16	85	3 3/8	1600	56.4
291225308	2 STBD								

## HTX Size 1 & 2 End Stops

### Impact End Stop



PART NO	SIZE	WORKING LOAD LIMIT		LENGTH		WIDTH		WEIGHT	
		KG	LB	MM	IN	MM	IN	G	OZ
291218818	1	500	1100	83	3 1/4	71	2 13/16	190	6.7
291228818	2	1000	2200	103	4 1/16	85	33/8	350	12.3

### Plunger Stop



PART NO	SIZE	WORKING LOAD LIMIT		LENGTH		WIDTH		WEIGHT	
		KG	LB	MM	IN	MM	IN	G	OZ
291218837	1	500	1100	83	3 1/4	71	2 13/16	245	8.6
291228837	2	1000	2200	103	4 1/16	85	33/8	475	16.8

### End Stop with Single Control Line Sheave



PART NO	SIZE	WORKING LOAD LIMIT		LENGTH		WIDTH		WEIGHT	
		KG	LB	MM	IN	MM	IN	G	OZ
291218805	1	500	1100	83	3 1/4	71	2 13/16	210	7.4
291228805	2	1000	2200	103	4 1/16	85	33/8	400	14.1

### End Stop with Double Control Line Sheaves



PART NO	SIZE	WORKING LOAD LIMIT		LENGTH		WIDTH		WEIGHT	
		KG	LB	MM	IN	MM	IN	G	OZ
291218806	1	500	1100	83	3 1/4	71	2 13/16	240	8.5
291228806	2	1000	2200	103	4 1/16	85	33/8	450	15.9

### End Stop with Single Control Line Sheave & Becket



PART NO	SIZE	WORKING LOAD LIMIT		LENGTH		WIDTH		WEIGHT	
		KG	LB	MM	IN	MM	IN	G	OZ
291218808	1	500	1100	83	3 1/4	71	2 13/16	240	8.5
291228808	2	1000	2200	103	4 1/16	85	3 3/8	450	15.9

### End Stop with Double Control Line Sheaves & Becket



PART NO	SIZE	WORKING LOAD LIMIT		LENGTH		WIDTH		WEIGHT	
		KG	LB	MM	IN	MM	IN	G	OZ
291218809	1	500	1100	83	3 1/4	71	2 13/16	270	9.5
291228809	2	1000	2200	103	4 1/16	85	3 3/8	500	17.6

### End Stop with Double Control Line Sheaves, Becket & Cleat



PART NO	SIZE	WORKING LOAD LIMIT		LENGTH		WIDTH		WEIGHT	
		KG	LB	MM	IN	MM	IN	G	OZ
291214815	1 PORT	500	1100	83	3 1/4	98	37/8	365	12.9
291215815	1 STBD								
291224815	2 PORT	1000	2200	103	4 1/16	132	5 3/16	740	26.1
291225815	2 STBD								

### End Stop Sheet Lead



PART NO	SIZE	WORKING LOAD LIMIT		LENGTH		WIDTH		WEIGHT	
		KG	LB	MM	IN	MM	IN	G	OZ
291218817	1	500	1100	160	6 5/16	71	2 13/16	600	21.2
291228817	2	1000	2200	205	8 1/16	85	3 3/8	1400	49.3

\* End stop WWL, cleat WLL shown on p354

### HTX Track End



PART NO	SIZE	LENGTH		WIDTH		WEIGHT	
		MM	IN	MM	IN	G	OZ
291219907	1	40	1 5/8	57.5	2 1/4	20	0.7
291229907	2	45	1 3/4	65	2 1/2	40	1.4

### Sz 1 & 2 HTX Spares and Accessories

#### Cleat Assembly for End stop (Pair)



PART NO	SIZE	WORKING LOAD LIMIT	
		KG	LB
291219905	1	200	440
291229905	2	300	660

#### Spare Slide Rods Kit



PART NO	SIZE
291219910	1
291229910	2

#### Spare Rubber Buffer Kit



PART NO	SIZE
291219911	1
291229911	2

#### HTX Upstand Kit



PART NO	SIZE
291219901	1
291229901	2

## 8. Hardware



### Genoa T-Track Cars

T-Track is widely used on cruising boats where car sheeting positions change frequently.

All Lewmar T-Track cars fit the industry standard: 32mm (1 1/4"). The cars are available in three styles and cover three different loading levels to suit boats from 9m (30ft) up to 15.5m (50ft).

- Precision Workmanship
- Simple to fit
- Three Styles
- Low Maintenance

#### Car with Shackle and Plunger



PART NO	SIZE	WORKING LOAD LIMIT		LENGTH		WIDTH		WEIGHT	
		KG	LB	MM	IN	MM	IN	G	OZ
29172117	2	1500	3300	120	4 11/16	56	2 1/4	480	17.0

#### Genoa Plunger Car



PART NO	SIZE	WORKING LOAD LIMIT		LENGTH		WIDTH		WEIGHT	
		KG	LB	MM	IN	MM	IN	G	OZ
29041700	1	900	1980	111	4 3/8	56	2 1/4	540	19.1
29042700	2	1500	3300	120	4 11/16	56	2 1/4	719	25.3
29043702	3	2350	5170	170	6 3/4	56	2 1/4	1199	47.3

#### Tri-Roller Genoa Car



PART NO	SIZE	WORKING LOAD LIMIT		LENGTH		WIDTH		WEIGHT	
		KG	LB	MM	IN	MM	IN	G	OZ
29442705	2	1500	3300	147	5 3/4	64	2 1/2	767	27.1

#### Track End Stop

PART NO	WEIGHT	
	G	OZ
29172016	19	0.7



#### T-Track Specification

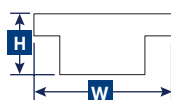
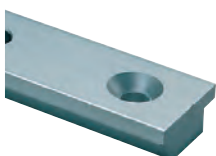

PART NO	NOMINAL LENGTH		H HEIGHT		W WIDTH		WEIGHT (PER METRE)		CENTRE HOLE		FIXINGS	
	M	FT	MM	IN	MM	IN	MM	IN	G	OZ	METRIC	IMPERIAL
	29166215	1.5	4'11"									
29166225	2.5	8'2"	15	5/8	32	1 1/4	865	30.5	100	3 15/16	CSK M8	5/16"
29166230	3.0	9'10"										



## Size 4 Cars and Accessories

For offshore yachts 60ft and over and the performance sailor.

- High load 80mm (3 1/8") control line sheaves for 14mm (9/16") line.
- 12mm (1/2") torlon balls running in fully machined ball races.
- Additional weight reducing slots machined along the top of the return ball race
- End stops fixed through deck and track
- Custom variants available - contact custom@lewmar.com

### Size 4 Racing Mainsheet car



29903402

PART NO	DESCRIPTION	WORKING LOAD LIMIT		LENGTH		WIDTH		WEIGHT	
		KG	LB	MM	IN	MM	IN	G	OZ
29903401	SINGLE UPSTAND AND SINGLE CONTROL LINE SHEAVES	8000	17634	465	18 3/8	113	4 7/16	5195	183.2
29903402	TWIN UPSTAND AND SINGLE CONTROL LINE SHEAVES	8000	17634	465	18 3/8	113	4 7/16	5195	183.2

### Size 4 Racing Genoa car



29903451/2

PART NO	DESCRIPTION	WORKING LOAD LIMIT		LENGTH		WIDTH		LINE EXIT HEIGHT		WEIGHT	
		KG	LB	MM	IN	MM	IN	MM	IN	G	OZ
29903451BK	GENOA STIRRUP @ DEAD EYE- PORT	6000	13225	385	15 1/8	113	4 7/16	137	5 3/8	6740	236.5
29903452BK	GENOA STIRRUP @ DEAD EYE- STARBOARD	6000	13225	385	15 1/8	113	4 7/16	137	5 3/8	6740	236.5
29903453	GENOA STIRRUP WITH SINGLE CL SHEAVE- PORT	6000	13225	385	15 1/8	113	4 7/16	137	5 3/8	6740	236.5
29903454	GENOA STIRRUP WITH SINGLE CL SHEAVE- STBD	6000	13225	385	15 1/8	113	4 7/16	137	5 3/8	6740	236.5
29903457	GENOA STIRRUP WITH SLIDE ROD PLUNGER- PORT	6000	13225	385	15 1/8	113	4 7/16	137	5 3/8	6740	236.5
29903458	GENOA STIRRUP WITH SLIDE ROD PLUNGER- STBD	6000	13225	385	15 1/8	113	4 7/16	137	5 3/8	6740	236.5

### Size 4 Racing End Stop

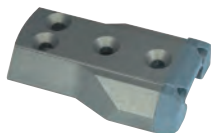

29905400



29905401



29905412



29905414

PART NO	DESCRIPTION	WORKING LOAD LIMIT		LENGTH		WIDTH		WEIGHT	
		KG	LB	MM	IN	MM	IN	G	OZ
29905400BK	HIGH LOAD IMPACT END STOP	4000	8817	185	7 1/4	113	4 7/16	1040	36.7
29905401BK	TRACK END	1000	2204	110	4 5/16	113	4 7/16	580	20.5
29905410	CONTROL LINE END STOP	6000	13225	185	7 1/4	113	4 7/16	1500	52.9
29905412	PLUNGER STOP	3000	6613	110	4 5/16	113	4 7/16	897	31.6
29905414	TRACK PLUG							36	1.3

### Size 4 Tracks

#### Size 4 Drilled plunger track Specifications & Fixing Details

PART NO	LENGTH		H HEIGHT		W WIDTH		WEIGHT (per metre)		MAX SPAN BETWEEN FIXINGS / CENTRE HOLE		FIXINGS	
	M	FT	MM	IN	MM	IN	G	OZ	MM	IN	METRIC	IMPERIAL
29917420BK	2	6'7"										
29917430BK	3	9'10"	29	1 1/6	50	2	2228	78.6	100	3 15/16	CSK M12	1/2
29917440BK	4	13'1"										
29917450BK	5	16'5"										

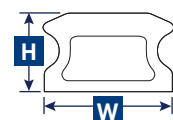

## 8. Hardware



### Lewmar Custom Yacht Systems

#### On Deck Control Systems

Custom yachts have individual requirements for sail control equipment, from application and loads to the profile of the deck on which the equipment will be installed. Each Lewmar track is designed with these specific requirements in mind.

Recent innovations included track that can be curved to bespoke dimensions, including multidirectional compound curves. The high load double ball race (DBR) profile offers a stronger, deeper section for use with high load cars, while T-track and DBR track feature machined track ends for a lightweight, low-profile car retention solution.

Lewmar Custom Mainsheet and Genoa systems are ideal for yachts from 21m (70ft) to 70m (230ft) in length. Each car is available with a choice of recirculating Torlon balls or the shorter, stronger Double Ball Race (DBR) configuration. Styled with snag-free soft edges, Lewmar cars are machined from solid to individual specifications. A full range of end stops are available, including high-load impact, plunger, and control line models.





## Below Deck Sheeting System

Each element of the Lewmar Custom Hardware Range is compatible with its counterparts, resulting in the ability to supply a complete, bespoke sail control system. For example, an increasing emphasis on beautiful, sleek, minimalistic lines has resulted in the below-deck sheeting system, which offers a light-weight, fully-optimised system that does not clutter the clean lines of the deck. With a choice of configurations and finishes available, Lewmar can provide a system suited to your individual requirements.

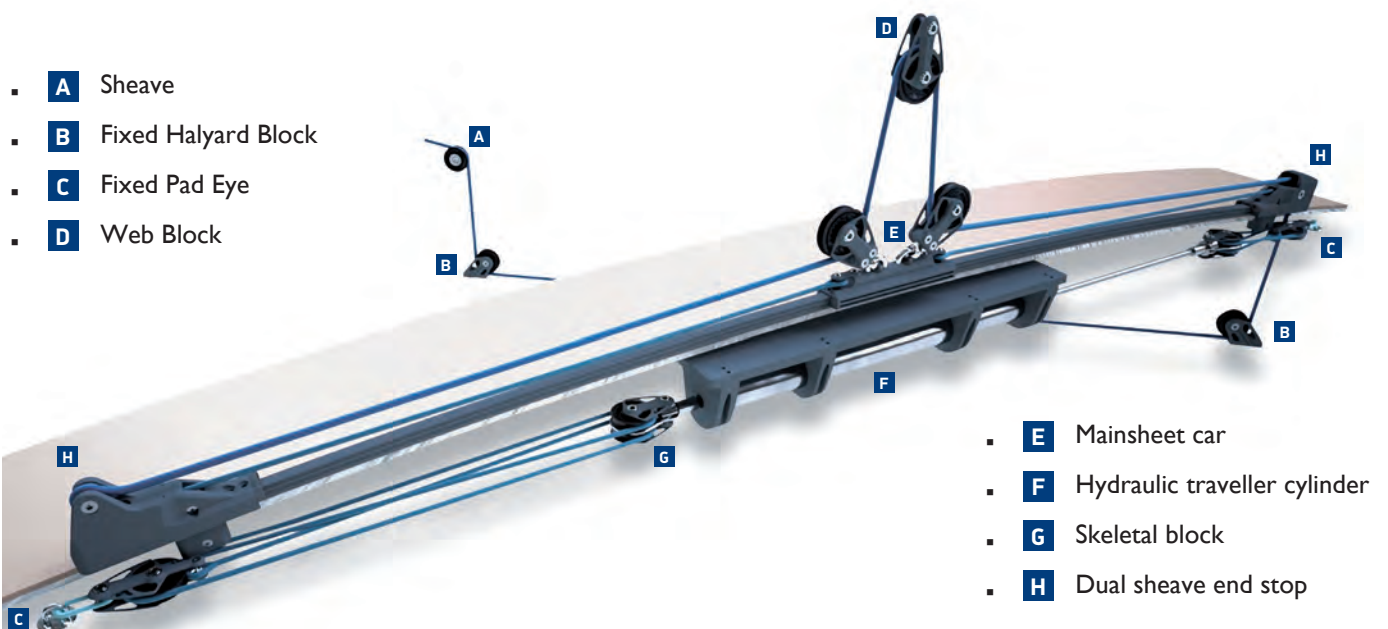

## 8. Hardware

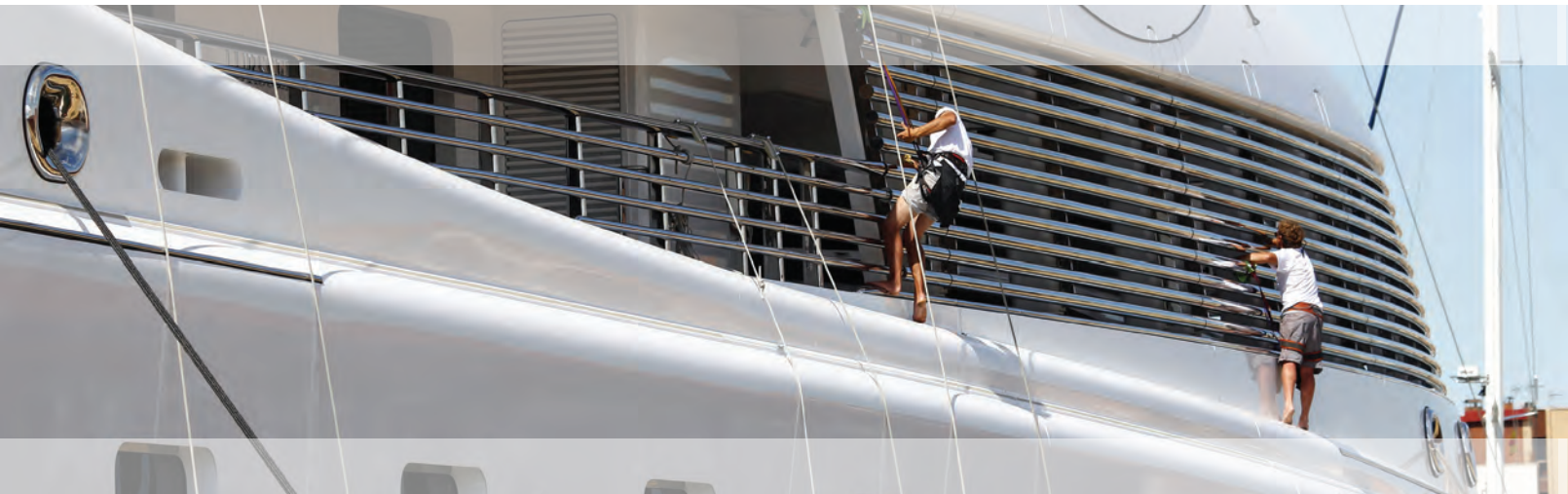

### Overside Work Rail System

Lewmar's Overside Work Rail System is designed to provide access to difficult areas at height. As a solution to a problem found across the marine sector and wider industry, our Overside System is well-designed and practical, conforming to necessary regulations.



#### 1. Safety Harness

- Use a full body safety harness attached to the plunger pin stop car slider.
- Full body harness must meet CE/ANSI support standards.

#### 2. Working Car

- Use a working harness or chair attached to access car.
- Working harness or chair must meet CE/ANSI standards.

#### 3. Tool Service Car (Optional)

- Attach an optional car and joiner link for use as a tool carrier

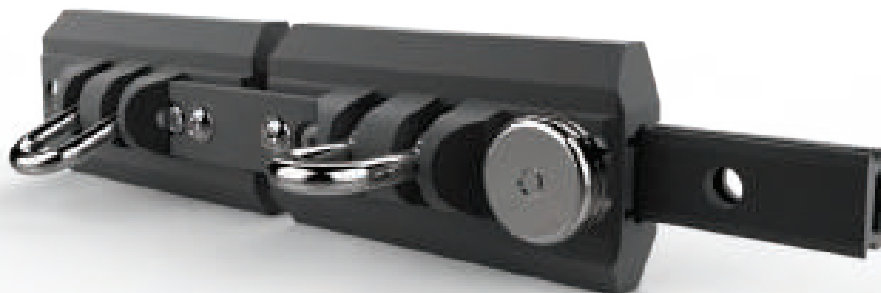

CE standard certification EN 795.



### Design

Two car system with lock plunger mechanism. The plunger feature allows movement along the track while open but can lock to position on the track while working. Offering ease of movement and strong stability when locked.

### Ball Bearings

Torlon® ball bearings handle high loads, reducing friction offering smooth operation along the track. Ball bearings circulate through open structure allowing easy cleaning when installed.

### Materials

Black Compact, one-piece aluminium body, Torlon® ball bearings & black anodized aluminium track.

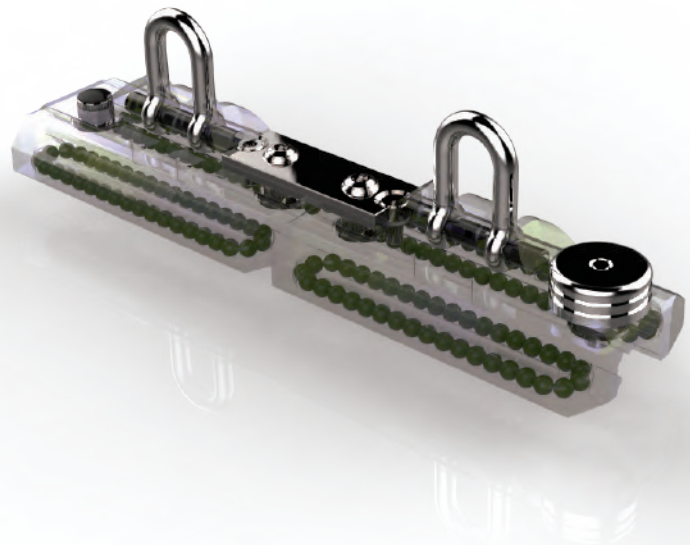

PART NO. BLACK	DESCRIPTION	SWL (KG)	LENGTH (MM)	WIDTH (MM)	WEIGHT (G)
29913313BK	SZ1 0/S WORK CAR DOUBLE	125	265	66	966
29913310BK	SZ1 0/S WORK CAR SINGL SHACKLE PLUNGER	125	130	66	476
29913311BK	SZ1 0/S WORK CAR SINGLE SHACKLE	125	130	66	402
29915075BK	SZ1 0/S RAIL IMPACT END	-	66	66	125
29913316	SZ1 0/S CAR LINK PLATE KIT	-	-	-	88
29915076	SZ1 JOINER INSERT HD	-	-	-	29
293712320BK	SZ1 0/S RAIL TRACK 2 MTR JOIN X2	-	2000	23	518
293712321BK	SZ1 0/S RAIL TRACK 2 MTR ENDX1 JOIN X1	-	2000	23	518
293712322BK	SZ1 0/S RAIL TRACK 2 MTR END X2	-	2000	23	518
293712330BK	SZ1 0/S RAIL TRACK 3 MTR JOIN X2	-	3000	23	1038
293712331BK	SZ1 0/S RAIL TRACK 3 MTR ENDX1 JOIN X1	-	3000	23	1038
293712332BK	SZ1 0/S RAIL TRACK 3 MTR END X2	-	3000	23	1038
293712340BK	SZ1 0/S RAIL TRACK 4 MTR JOIN X2	-	4000	23	2081
293712341BK	SZ1 0/S RAIL TRACK 4 MTR ENDX1 JOIN X1	-	4000	23	2081
293712342BK	SZ1 0/S RAIL TRACK 4 MTR END X2	-	4000	23	2081

# CE

### Certification

CE certified and tested under certification EN 795.

## 8. Hardware



### Clutches

Lewmar continues to define rope clutch technology with a variable geometry handle and unique grip pattern of dominos that prevent rope fray. This revolutionary system has been independently tested time and again and has won awards for its innovative framework.

- A** Domino Cluster and longer holding pattern holds line under load without fraying the rope
- B** Controlled Release – Pull back handle combined with patented clutch and release mechanism provides controlled release even at full holding load
- C** Handle has a solid link to the domino cluster
- D** Line Size – Clutches capable of holding lines from 6mm (1/4") to 14mm (9/16")

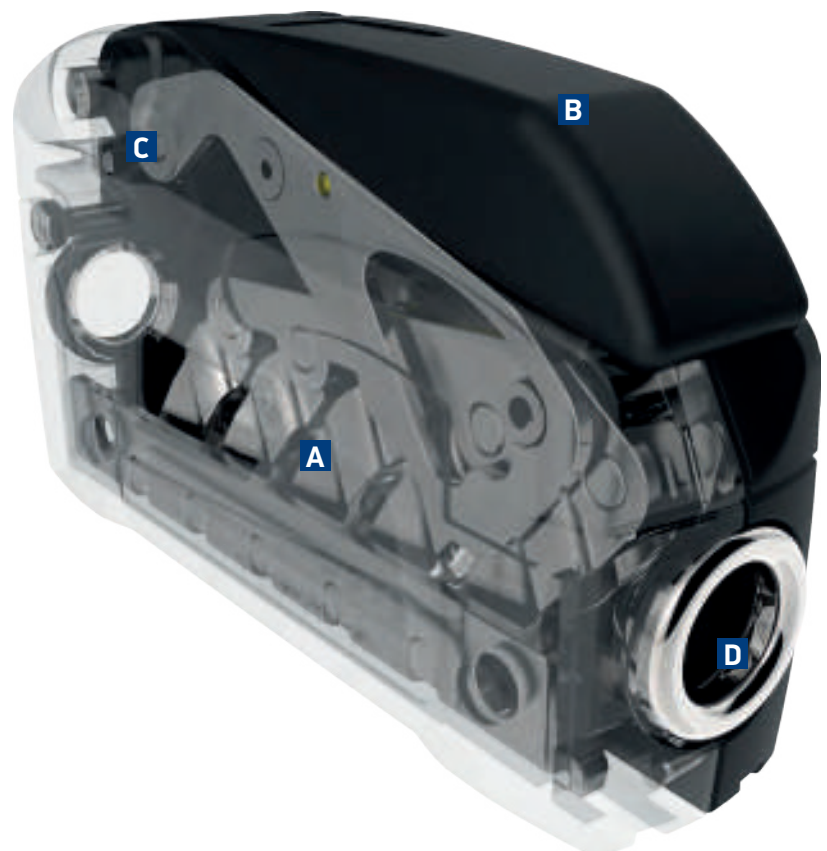

Instead of just jamming the rope...



... Lewmar's Domino mechanism flexes it for better grip and less rope wear.



## DC Rope Clutches



DC1 Single



DC1 Double



DC1 Triple



DC2 Single



DC2 Double



DC2 Triple

### DC1 Rope Clutch Specifications

PART NO	DESCRIPTION	LINE SIZE		MIN HOLDING LOAD		APPROX WEIGHT		WLL	
		MM	IN	KG	LB	G	OZ	KG	LB
29101108BK	6-8 MM DC1 SINGLE	6-8	1/4-5/16	300	661	330	12	500	1100
29101208BK	6-8 MM DC1 DOUBLE					650	23	500	1100
29101308BK	6-8 MM DC1 TRIPLE					850	30	500	1100
29101110BK	8-10 MM DC1 SINGLE	8-10	5/16-3/8	400	880	330	12	500	1100
29101210BK	8-10 MM DC1 DOUBLE					650	23	500	1100
29101310BK	8-10 MM DC1 TRIPLE					850	30	500	1100
29101112BK	10-12 MM DC1 SINGLE	10-12	3/8-7/16	500	1100	330	12	500	1100
29101212BK	10-12 MM DC1 DOUBLE					650	23	500	1100
29101312BK	10-12 MM DC1 TRIPLE					850	30	500	1100
29100010BK	DC1 HANDLE KIT								
25002323	CLUTCH LABEL KIT								

### DC2 Rope Clutch Specifications

PART NO	DESCRIPTION	LINE SIZE		MIN HOLDING LOAD		APPROX WEIGHT		WLL	
		MM	IN	KG	LB	G	OZ	KG	LB
29101410BK	8-10MM DC2 SINGLE	8-10	5/16-3/8	500	1102	650	23	1200	2650
29102410BK	8-10MM DC2 DOUBLE					1216	43	1200	2650
29103410BK	8-10MM DC2 TRIPLE								
29101412BK	10-12MM DC2 SINGLE	10-12	3/8-1/2	700	1550	650	23	1200	2650
29102412BK	10-12MM DC2 DOUBLE					1216	43	1200	2650
29103412BK	10-12MM DC2 TRIPLE								
29101414BK	12-14MM DC2 SINGLE	12-14	1/2-9/16	1000	2204	650	23	1200	2650
29102414BK	12-14MM DC2 DOUBLE					1216	43	1200	2650
29103414BK	12-14MM DC2 TRIPLE								
29101501BK	DC2 HANDLE KIT								
25002323	CLUTCH LABEL KIT								

# 8. Hardware

## DC1 & DC2 Rope Clutch Dimensions

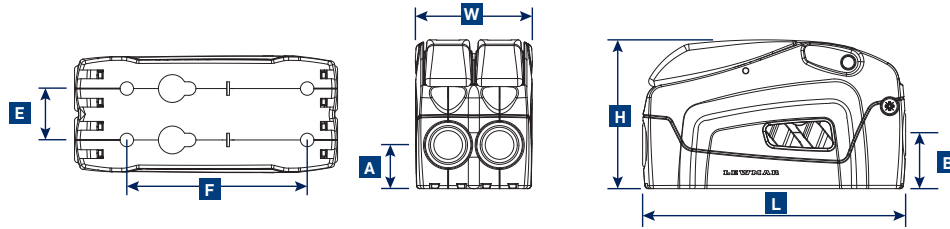

Notes:

Line entry and exit angle should not exceed 15° from the rope clutch centre line

DC1 : Use pan head M6 – 1/4" fixings – do not tighten beyond 10 Nm torque

DC2 : Use pan head M8 - 5/16" fixings - do not tighten beyond 22Nm torque

SIZE	L LENGTH		W WIDTH		H HEIGHT		A LINE ENTRY		B LINE EXIT		E FIXINGS WIDTH		F FIXINGS LENGTH	
	MM	IN	MM	IN	MM	IN	MM	IN	MM	IN	MM	IN	MM	IN
D1 SINGLE			32	1 5/16							-	-		
D1 DOUBLE	126	5	57.85	2 5/16	72	2 13/16	27	1 1/8	29	1 3/16	26	1	79	3 1/8
D1 TRIPLE			83.7	3 5/16							26	1		
D2 SINGLE			38.0	1 1/2							-	-		
D2 DOUBLE	156	6 1/8	68.5	2 1/16	88	3 3/8	26	1	32	1 5/16	30.5	1 3/16	107	4 1/4
D2 TRIPLE			99	3 7/8							30.5	1 3/16		

## Clutch Selection Guide

APPLICATION	M FT	BOAT LENGTH OVERALL											
		7.6 25	8.8 29	10.1 33	10.7 35	11.3 37	11.9 39	12.5 41	14.6 48	16.8 55	18.9 62	21.5 70	
HALYARDS	MAIN	DC1 ROPE CLUTCH											
	GENOA	DC1 ROPE CLUTCH											
	SPINNAKER	DC1 ROPE CLUTCH											
GOOSENECK	REEF LINES	DC1 ROPE CLUTCH											
	OUTHAUL	DC1 ROPE CLUTCH											
	FLATTENER	DC1 ROPE CLUTCH											
POLE/BOOM LIFT	SPIN POLE UPHAUL	DC1 ROPE CLUTCH											
	SPIN POLE DOWN HAUL	DC1 ROPE CLUTCH											
	HEEL LIFT	DC1 ROPE CLUTCH											
	MAIN BOOM TOPPING LIFT	DC1 ROPE CLUTCH											
FURLING LINES	GENOA	DC1 ROPE CLUTCH											
	MAIN	DC1 ROPE CLUTCH											
SHEETS	MAINSHEET 4:1 PURCHASE	DC1 ROPE CLUTCH											
CONTROL LINES	MAINSHEET CAR (2:1 PURCHASE)	DC1 ROPE CLUTCH											
	GENOA CAR (2:1 PURCHASE)	DC1 ROPE CLUTCH											
	POLE OUTHAUL	DC1 ROPE CLUTCH											
	KICKING STRAP/VANG	DC1 ROPE CLUTCH											

DC1 ROPE CLUTCH

DC2 ROPE CLUTCH



## Organisers

All organisers have space to pass two lines between each sheave

### Flush fixings Synchro Organiser

- Bushed sheaves with side thrust ball bearings
- Wide rope entry



PART NO	SHEAVE Ø		NO OF SHEAVES	WORKING LOAD LIMIT		MAX WORKING LOAD OF SHEAVE		MAX LINE SIZE		LENGTH		WEIGHT		FIXINGS (NOT SUPPLIED)	
	MM	IN		KG	LB	KG	LB	MM	IN	MM	IN	G	OZ	MM	IN
29916042BK	60	2 3/8	6	3700	8156	1100	2420	12	1/2	256	10 1/16	602	21.2	M10	3/8
29916060BK	60	2 3/8	3	2550	5500	1100	2420	12	1/2	256	10 1/16	329	12.9	M10	3/8

### 40 and 60mm Bushed Sheaves Organiser

- Tough interchangeable acetal or alloy sheaves (40mm only)
- Stackable



PART NO	SHEAVE Ø		NO OF SHEAVES	WORKING LOAD LIMIT		MAX WORKING LOAD OF SHEAVE		MAX LINE SIZE		LENGTH		WEIGHT		FIXINGS (NOT INCLUDED)		SHEAVE CENTRES	
	MM	IN		KG	LB	KG	LB	MM	IN	MM	IN	G	OZ	MM	IN	MM	IN
29139122BK	40	1 5/8	2	1005	2215	750	1654	10	3/8	142	5 5/8	123	271	M8	5/16	47	1 7/8
29139123BK	40	1 5/8	3	1507	3322	750	1654	10	3/8	189	7 3/8	206	454	M8	5/16	47	1 7/8
29139124BK	40	1 5/8	4	2010	4431	750	1654	10	3/8	236	9 1/3	275	606	M8	5/16	47	1 7/8
29139125BK	40	1 5/8	5	2512	5537	750	1654	10	3/8	283	11 1/8	352	776	M8	5/16	47	1 7/8
29139126BK	40	1 5/8	6	3015	6646	750	1654	10	3/8	330	13	425	937	M8	5/16	47	1 7/8
29139112BK	60	2 3/8	2	2400	5290	1200	2645	14	9/16	231	9 1/8	325	11.46	M10	3/8	72	2 27/32
29139113BK	60	2 3/8	3	3000	6613	1200	2645	14	9/16	303	12	435	15.34	M10	3/8	72	2 27/32
29139114BK	60	2 3/8	4	3600	7935	1200	2645	14	9/16	375	14 3/4	551	19.43	M10	3/8	72	2 27/32
29139115BK	60	2 3/8	5	4200	9258	1200	2645	14	9/16	447	17 5/8	637	22.46	M10	3/8	72	2 27/32
29139116BK	60	2 3/8	6	4800	10580	1200	2645	14	9/16	519	20 1/2	775	27.33	M10	3/8	72	2 27/32

### Stainless Steel Bushed Sheaves Organiser

To complement our HTX Stainless Steel Block range, Lewmar have developed a stainless steel organiser to complete the installation.

- Same technical specifications as alloy versions, but with additional aesthetic appeal
- Machined from marine-grade stainless steel

Contact your Lewmar representative to find out more information.

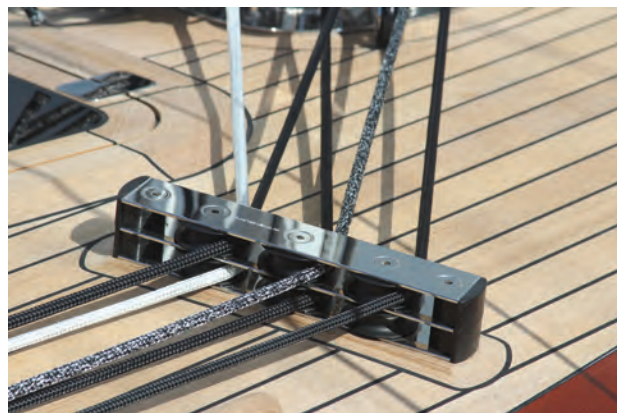

# 8. Hardware

## Cleats

Made from state-of-the-art materials developed by the automotive industry and refined for the marine market, Lewmar cleats enhance performance in durability, strength and lubrication.

### Features

- Low line entry load
- High holding load
- Constant tension springs

- Wash-out bearing slots
- Split base fairlead to facilitate continuous line installations

## Cam Cleats

PART NO	DESCRIPTION	WLL		LINE SIZE		FIXING PITCH		FIXING SIZE		WEIGHT	
		KG	LB	MM	IN	MM	IN	MM	IN	G	OZ
29104100BK	SMALL COMPOSITE CLEAT	120	264	2-8	5/64-5/16	27	1 1/16	M4	5/32	17.5	0.6
29104110BK	MEDIUM COMPOSITE CLEAT	180	396	4-12	5/32-1/2	38	1 1/2	M5	3/16	48.5	1.7



## Fairlead



PART NO	DESCRIPTION	LINE SIZE		WEIGHT	
		MM	IN	G	OZ
29104104BK	TO FIT 29104100	2-8	5/64-5/16	6.0	0.2
29104114BK	TO FIT 29104110	4-12	5/32-1/2	14.0	0.5

## Feeder Loop



PART NO	DESCRIPTION	LINE SIZE		WEIGHT	
		MM	IN	G	OZ
29104115	SMALL	2-8	5/64-5/16	6.0	0.2
29104116	MEDIUM	4-12	5/32-1/2	10.0	0.35

## Eye Strap (Pair)



PART NO	DESCRIPTION	LINE SIZE		FIXING PITCH		FIXING SIZE		WEIGHT	
		MM	IN	MM	IN	MM	IN	G	OZ
29104103	SMALL	2-8	5/64-5/16	27	1 1/16	M4	5/32	6.0	0.2
29104113	MEDIUM	4-12	5/32-1/2	38	1 1/2	M5	3/16	18.0	0.6

## Bulls-Eyes



PART NO	DESCRIPTION	MAX LINE SIZE		FIXING PITCH		FIXING SIZE		WEIGHT	
		MM	IN	MM	IN	MM	IN	G	OZ
29904117	MEDIUM	12	1/2	25	1	M4	5/32	12.0	0.4
29904118	LARGE	18	3/4	32	1 1/4	M5	3/16	32.0	1.1

## Swivel Cam Base for 60/80mm Blocks



PART NO	WLL		LINE SIZE		FIXING PITCH		FIXING SIZE		WEIGHT	
	KG	LB	MM	IN	MM	IN	MM	IN	G	OZ
29904126	300	661	4-10	5/32-7/16	4X19	4X3/4	M5	3/16	302	10.7

## Swivel Small Cam with Bull's Eye



PART NO	DESCRIPTION	LINE SIZE		HOLE CENTRES		WEIGHT	
		MM	IN	MM	IN	G	OZ
29904105	SMALL	2-6	5/64-1/4	3 X 27	3 X 1 1/16	114	4
29904115	MEDIUM	4-10	5/32-3/8	3 X 27	3 X 1 1/16	168	5.9

GREY CLEAT AND FAIRLEAD ALSO AVAILABLE



## 9. Steering



Lewmar's steering systems have been world leaders for over 50 years, and are constantly evolving to meet the performance and aesthetic needs of both cruisers and elite racers. With ranges designed for a range of applications, Lewmar steering is an ideal solution for production and custom projects.

# 9. Steering

## The Lewmar Steering Range



### Page 357 Steering Systems

- Comprehensive range of steering systems
- Constellation – Open wire and wire-in-conduit steering.
- Cobra – Rack and Pinion
- Mamba – Rotating Torque Tube and Bevelhead steering.



### Page 375 Rudder bearing

- Range of rudder bearings complement Lewmar Steering Systems
- Suitable for tiller-steered and wheel-steered yachts
- Full range of accessories



### Page 376 Wheels

- Choice of wheels to suit any application
- 25mm/1" tapered keyed shaft ensures positive fit
- Compatible with all Lewmar Steering Systems
- Full range of accessories available



### Page 380 Powerboat Wheels

- Range of Powerboat wheels
- Deep dish design for extra room and comfort
- Pre-assembled with ball-raced Power Grip for ease of use



### Page 383 Pedestals

- Range of standard and custom pedestals
- Modern composite construction guards against corrosion
- Custom pedestals available for bespoke specification
- Range of accessories available, including guardrails



### Page 387 Instrument Pods

- Choice of instrument pods to suit any electronic configuration
- Pods available as retrofit or complete assembly option



### Page 390 Cockpit Accessories

- Range of cockpit tables in different finishes
- Tables and pods designed to complement Lewmar Pedestal Range



### Page 391 Autopilot Drives

- Simple installation
- Compatible with main electronic suppliers
- All units feature electromechanical clutch
- Low current draw

## Steering Overview

### Constellation™ System – Wire steering

Constellation™ is the main wire steering system available for yachts from around 7m/25ft – 18m/60ft. They can be in either single or tandem systems - ideal for aft cockpit installations - and are the most reliable systems on the market. The conduit system overcomes the difficulties that are experienced when using open wire in centre cockpit installations.



### Cobra™ System – Rack and Pinion

The Cobra™ system is an industry leader in its field and designed for aft-cockpit yachts. The system uses rack and pinion to ensure the necessary mechanical advantage required for sensitive steering. Lewmar also offers a bespoke Cobra™ system for use on non-aft cockpit yachts.



### Mamba™ System – Rotating Torque Tube and Bevelhead

Mamba™ is a suitable system for a diverse range of sail boats, from bluewater cruisers to round-the-world racers. It offers unique features - such as variable mechanical advantage steering - while retaining versatility in the type of installation, such as tandem systems. The Mamba™ system ensures positive steering feedback and strength; inherent benefits in gearbox and bevel head steering systems.



### Cassette Steering System

Lewmar's revolutionary cassette steering system is an innovative blend of product experience. Constellation™ wire extends from the pedestal and connects to our proven, marine-grade, ball bearing traveller car and track. Then, using the components of the Mamba™ solid system, it connects the track and car to the rudder blades. The entire system is lightweight with multiple mounting possibilities and responsive feedback when sailing.



## 9. Steering



### Constellation™ Systems

Constellation™ is made up of a complete range of wire steering systems, offering award-winning design and high quality construction, for vessels up to 18m/60ft. The systems have been developed in conjunction with both production boat yards and the world's racing community. All aluminium parts are etched, alchromed and stoved using powder-coated polyester resins.

- Simple installation with minimal components
- Classic 'tried and tested' chain and wire arrangement
- Open wire arrangements for aft cockpit boats with a wire in conduit option for centre cockpit
- Range of sprocket / quadrant ratios available for different steering speeds and loads
- Autopilot units can be easily incorporated into the system





## Constellation™ Wire-in-Conduit Systems

Due to their ease of installation, wire-in-conduit systems have largely replaced open wire for centre cockpit yachts. Advances in conduit technology have resulted in Constellation™ systems that are simple to install and easy to maintain. Self-contained sheave assemblies have been developed to fit into the conduit route, eliminating the requirement for reinforced pads.

Lewmar offer a range of components to complete your wire-in-conduit installation, including conduit end fittings, conduit greasers and terminal units to align the cables with the quadrants. Most common conduit installation for centre cockpit yachts up to 12m/40ft.

- Simple to install
- Ultimate reliability
- Pedestal or bulkhead mounting for wheels
- Heavy duty double armoured conduit with low-friction liner to ensure efficiency
- In-line conduit greasers



To achieve the maximum sensitivity and longevity from a conduit system please follow the following guidelines:

- Keep the number of bends to a minimum.
- Do not exceed 270° of total curves.
- Avoid 'S' bends.
- Orientate the quadrant to achieve the best conduit lead.
- Minimum bend radius 200mm/8".

## 9. Steering

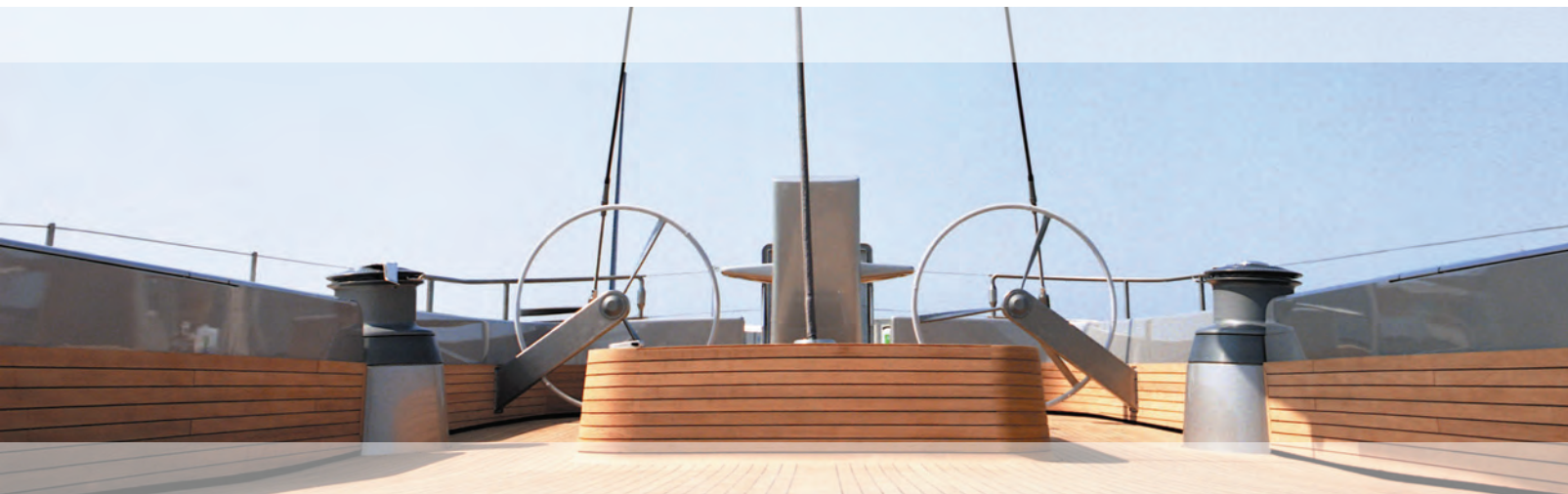

### Constellation™ Systems

#### Constellation™ Open Wire Systems

##### Aft Cockpit Radial Steering Systems

The simplest wire system available for aft cockpit yachts with vertical, or near vertical, rudders using a radial quadrant in conjunction with a cross wire idler, (universal idler if the pedestal is mounted aft of the rudder stock). Dependent on sheave and quadrant sizes, this equipment can be employed on sailing yachts up to approximately 18m /60ft.

Please note the sheaves are fully articulated to obtain perfect lead from sheave to quadrant. The splay angle is dependent on the distance from pedestal centre to rudder stock and the quadrant diameter.

- Steering shaft supported in triple high efficiency ball bearings, ensuring no axial and radial play
- Cross wire idlers, bevelled & adjustable to ensure perfect cable alignment
- High strength Alloy quadrants for maximum reliability and compactness
- Range of terminal units, sheaves, bulkhead steerers, quadrants and accessories
- Efficient installation
- Multiple pedestals sprocket options, dependent on boat size (Contact a Lewmar Dealer)
- Electrostatically applied, polyester coating for maximum protection against corrosion
- Integrated autopilot drive kit for mounting drive units

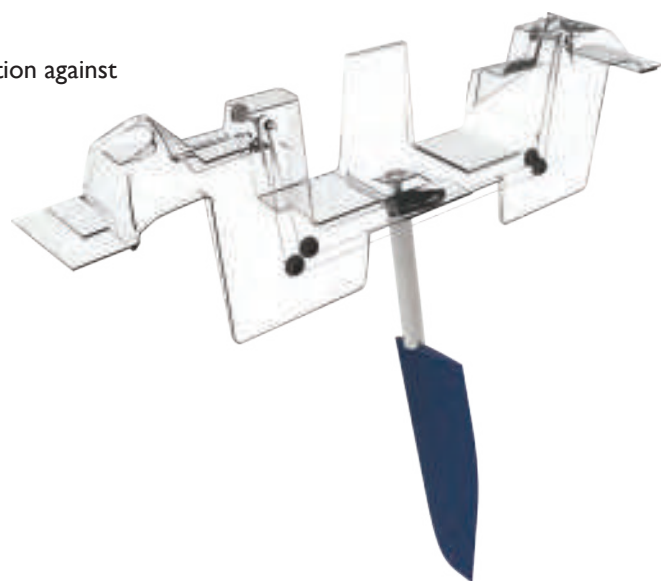



## Constellation™ Chain & Wire Accessories

### Breaking Strength

The figures shown in the tables below indicate the minimum breaking load of Lewmar cables and chain. Due to the reduction in strength caused by cable fatigue over time, the load on the cable should never exceed 25% of the breaking strain shown, i.e. Safety Factor = 4.

A 305mm/12" radius quadrant used in conjunction with 6mm/0.23" wire is suitable for the rudder torque, as in the example calculation shown on the right.

- Precision engineered in non magnetic stainless steel
- Cable can be supplied to be finished with eyebolts and thimbles
- 2 off master links for easy connection to the cable
- Fully assembled with pre-swaged eyebolts available
- Custom length chain sets available on request
- Cable supplied in 7 x 19 stainless steel stranded construction

$$\text{Torque} = \text{Breaking Load} \times \text{Radius} \times \text{Safety Factor}$$

Metric Example

$$= 2040\text{Kg} \times 0.305\text{m} \times 0.25$$

$$= 155 \text{ mKg}$$

Imperial Example

$$= 4500\text{lb} \times 12" \text{ radius} \times 0.25$$

$$= 13500 \text{ in.lb}$$

### Non-Magnetic Stainless Steel Roller Chain Assemblies

PART NO.	ANSI SPEC	PITCH INCHES	BREAKING LOAD	
			KG	LB
89100090	ANSI 50	5/8	2267	5000
89100093	ANSI 60	3/4	3175	7000



Wire and Chain assembly

### Steering Cable 7 x 19 Stranded Stainless Steel

PART NO.	CABLE DIAMETER		BREAKING LOAD	
	MM	IN	KG	LB
R19-050	5	0.1	1406	3100
89100078	6	0.2	2040	4500

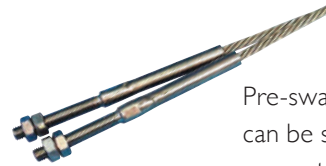

Pre-swaged cables can be supplied on request

## Constellation™ Quadrant, Sprocket & Chain Kit Specification Table

The following table illustrates the turns at the helm for a range of standard sprocket and quadrant sizes.

Lewmar offer custom quadrants in 6082T6 alloy up to 020 mm (40")

Lewmar also offers custom sprockets with any number of teeth in 15.87mm (5/8") or 19.05mm(3/4") or 25.4mm(1") pitch stainless steel or 6082T6 high strength aluminium.

PART NO.		QUADRANT TYPE	SPROCKET SIZE VS TURNS HO/HO FOR 72° RUDDER TRAVEL			
<sup>5</sup> / <sub>8</sub> " P SPROCKET	<sup>3</sup> / <sub>4</sub> " P SPROCKET		<sup>5</sup> / <sub>8</sub> " P 11T	<sup>5</sup> / <sub>8</sub> " P 13T	<sup>5</sup> / <sub>8</sub> " P 15T	<sup>3</sup> / <sub>4</sub> " P 11T
89100090	89100093	152MM/6" RADIUS 260°	1.08	0.92	0.79	0.9
89100090	89100093	190MM/7.5" RADIUS 80°	1.35	1.14	1.0	1.12
89100090	89100093	203MM/8" RADIUS 260°	1.44	1.22	1.06	1.2
89100090	89100093	228MM/9" RADIUS 260°	1.62	1.37	1.18	1.35
89100090	89100093	254MM/10" RADIUS 260°	1.8	1.52	1.32	1.5
89100090	89100093	304MM/12" RADIUS 80°	2.2	1.86	1.61	1.8
89100090	89100093	304MM/12" RADIUS 260°	2.2	1.86	1.61	1.8
89100091	89100094	381MM/15" RADIUS 80°	2.71	2.29	1.98	2.25
89100091	89100094	381MM/15" RADIUS 260°	2.71	2.29	1.98	2.25
89100091	89100094	457MM/18" RADIUS 80°	3.25	2.75	2.38	2.7
89100091	89100094	457MM/18" RADIUS 260°	3.25	2.75	2.38	2.7
89100092	89100095	508MM/20" RADIUS 80°	3.61	3.05	2.64	3
89100092	89100095	609MM/24" RADIUS 80°	4.35	3.68	3.19	3.6
89100100	89100096	762MM/30" RADIUS 80°	5.44	4.6	4.0	4.5



### Conduit

PART NO.	DESCRIPTION
89100069	CONDUIT (SOLD PER METER)
89100116	CONDUIT END FITTING

## 9. Steering

### Constellation™ Self Aligning Steerers

The Bulkhead steerer incorporates twin high efficiency ball races, which are double sealed and pre-lubricated for a long and maintenance free life.

- Self Aligning ball to take up misalignment or draft angle when installing within a console.
- Compact installation with a minimum distance of 100mm/4" between bulkhead faces.
- Available with sliding sprocket to aid line up with multiple sheaves.
- Steering shaft supported by high efficiency sealed-for-life bearings.
- Through-shaft mounted friction brake.
- Forward & aft flange housing manufactured in polymer composite material or Stainless Steel.
- Incorporates twin high efficiency, double sealed ball races
- Rapid and simple installation
- Stainless steel backing plate for maximum rigidity
- Variety of sprocket sizes
- Custom steering shafts available



Composite Self Aligning Steerer



Stainless Steel Self Aligning Steerer

PART NO.	DESCRIPTION
89101097	ST/ST SA STEERER 11T 196MM WITH BRAKE
89101098	ST/ST SA STEERER 11T 196MM NO BRAKE
89100102	COMPOSITE SA STEERER D200 ANSI 50-11T WITH BRAKE
89100149	COMPOSITE SA STEERER D200 ANSI 50-11T NO BRAKE

ONLY STANDARD PART NUMBERS LISTED ABOVE. OTHER VARIATIONS AVAILABLE. CONTACT YOUR LEWMAR REPRESENTATIVE FOR MORE INFORMATION

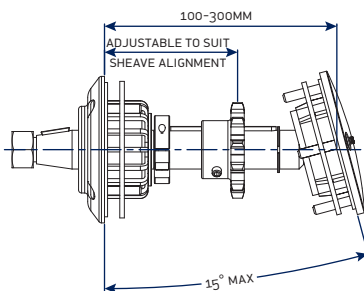

### Constellation™ Stainless Steel Bulkhead Steerers

Comes complete with a through shaft friction brake.

- Manufactured in investment cast Stainless Steel
- Steering shaft supported by a pre-lubricated sealed ball race bearing which enables low friction

PART NO.	DESCRIPTION
89101173	BULKHEAD STEERER ANSI 50-10T WITH BRAKE
89101174	BULKHEAD STEERER ANSI 50-10T NO BRAKE
89101144	BULKHEAD STEERER ANSI 50-13T WITH BRAKE
89101145	BULKHEAD STEERER ANSI 50-13T NO BRAKE

ONLY STANDARD PART NUMBERS LISTED ABOVE. OTHER VARIATIONS AVAILABLE. CONTACT YOUR LEWMAR REPRESENTATIVE FOR MORE INFORMATION

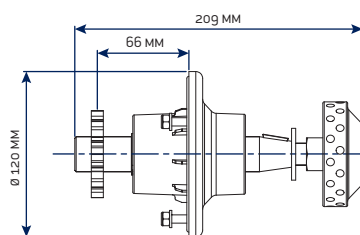

Stainless Steel Bulkhead Steerer - 10 tooth with brake

## Constellation™ Sheave Assemblies

Lewmar offer an extensive range of open-wire sheave assemblies from 102mm (4") to 254mm (10") diameters in different configurations: upright, flat, articulated, idlers and conduit to sheave adaptor.

- Available in bronze, aluminium and A100 glass reinforced nylon.
- High operation efficiency and sensitive steering operation – sheaves run on 45mm/1.77" caged roller bearings or closed tolerance plain bearings.
- All open-wire sheave assemblies incorporate wire guides to prevent cable jump
- Idlers are designed to prevent chafing when the cable straightens into the sheave track.



Single Articulated Sheave



Double Upright Sheave Assembly



Double Conduit to Sheave adaptor



Cross Wire Idler

## Constellation™ Quadrants

Lewmar offers a range of Alloy 80° and 260° quadrants.

- Fabricated from 6082 aluminium alloy
- Strong yet flexible, almost impossible to fracture under impact loading
- Compact, ideal if transom space is restricted
- Attachment point for linear drives on larger quadrants
- Quadrants with integral stopping surfaces for use against the rudder stop
- Radial versions supplied pre-drilled for optional bolt on stop block
- Generous groove depths and a large guide bend radii, for longevity of the cable.
- 80° quadrants supplied with cable retaining pins to prevent cable jump



### 80° Alloy High Strength Quadrants

L1 OPERATING RADIUS		MAXIMUM BORE SIZE Ø		H1 BOSS HEIGHT	
MM	IN	MM	IN	MM	IN
190	7.5	80	3	60	2.4
228	9	80	3	60	2.4
305	12	80	3	60	2.4
305	12	100	4	60	2.4
381	15	80	3	60	2.4
381	15	100	4	60	2.4
457	18	100	4	60	2.4
457	18	125	5	80	4.0
508	20	125	5	80	4.0
610	24	125	5	80	4.0

QUADRANTS CAN BE SUPPLIED PILOT BORED OR MACHINED TO SUIT

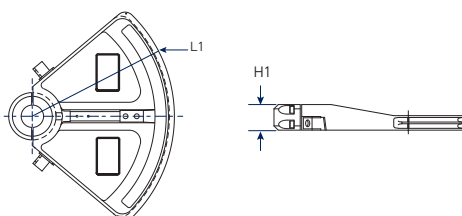

### 260° Alloy High Strength Quadrants

L1 OPERATING RADIUS		MAXIMUM BORE SIZE Ø		H1 BOSS HEIGHT	
MM	IN	MM	IN	MM	IN
152	6	80	3	60	2.3
203	8	80	3	60	2.3
254	10	80	3	60	2.3
254	10	100	4	60	2.3
305	12	100	4	60	2.3
381	15	125	5	80	4.0
457	18	125	5	80	4.0

QUADRANTS CAN BE SUPPLIED PILOT BORED OR MACHINED TO SUIT

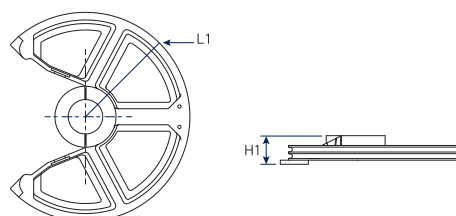

### Eye bolt tensorer kits

Eye bolt/cable tensorer are not supplied with quadrants and must be ordered separately

8g100196 Eye bolt tensorer kit for 6mm wide cable

## 9. Steering



### Cobra™ Systems

With over 40 years technological development, Cobra™ has become the first choice for boat builders worldwide for aft cockpit vessels. Cobra™ systems are the world leader in terms of performance, reliability and appearance for Rack and Pinion.

- Typically designed for aft cockpit boats with a short distance between the helm and the rudder
- Simple installation providing a direct feel and rudder response
- Adaptable for twin helm / twin rudder solutions
- Compact installation for boats with minimal space available
- Strong and light – no parts to fret or chafe
- Minimum maintenance
- Smoother operation
- Greater torque capability
- Full CE Certification available

### Principle of Operation

The principle of the Cobra™ steering system is based on the precision gearcut circular rack and pinion in the head of the pedestal providing the necessary mechanical advantage (see wide angle geometry). The quadrant gear is connected to a stainless steel downtube, at the base of which is an output lever. This connects to a similar lever, mounted on the rudder stock, via a fully adjustable draglink.

All shaft work is carried through high-efficiency sealed ball races and the mesh of gears is controlled via shims under the input, eliminating any lost motion. The input socket also houses a powerful and progressive friction brake for dampening the wheel, when at anchor, for example.





## Wide Angle Geometry

The lever geometry for Lewmar transmission systems is based on the principle of Wide Angle Geometry. This results in a very direct steering at midships and a more indirect and powerful steering at full rudder.

Due to this unique feature, the total number of turns of the wheel on a transmission steering system can be reduced by 30-40% compared to a cable system with the same maximum rim loads. This effect is achieved by an unequal length of the output and tiller lever. The output lever has 134mm centres and the tiller lever 203mm. The diagram to the below left shows the mechanical advantage (lever reduction) in relation to the rudder angle. Around amidships the reduction is quite constant, and above 15 degrees rudder the mechanical advantage nearly doubles compared to the amidships advantage.

The consequence of wide angle geometry is the offset angle of the levers in amidships position. This offset angle is necessary to achieve the same travel to port and starboard. The offset angle varies with the distance from the output lever to the tiller lever. Offset angles can be avoided when the complete gearbox is put on an offset distance.

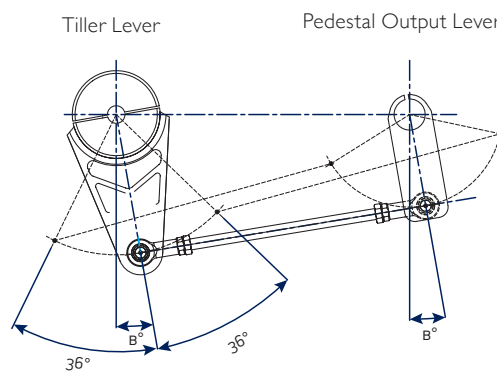

Different gear ratios can be used to suit all applications:

TYPE	GEAR RATIO	MECHANICAL ADVANTAGE AT MIDSHIPS	TURNS HO/HO	MAX RUDDER TORQUE		TYPICAL BOAT SIZE	
				NM	FT.LB	M	FT
COBRA™ CRUISING	5:1	8:1	1.77	2943	2170	13.7	45
COBRA™ BASE UNIT	5:1	8:1	1.77	2943	2170	13.7	45
COBRA™ RACING	4:1	6:1	1.4	4557	3360	16.7	55
COBRA™ OCEAN	6.7:1	10.2:1	2.45	4905	3617	18.3	60

## 9. Steering



### Cobra™ Systems

#### Cobra™ Installation Guidelines

##### L1 Standard pedestal height

L1 = 710mm/28". Range from 178mm/7" to 915mm/36".

##### L2 Standard under deck dimension

L2 = 102mm/4". The minimum dimension is governed only by the thickness of the cockpit sole. Where an extended L2 under deck is required, it may be necessary to also add a torque snubber plate.

##### L3 The distance between the centre of pedestal and the rudder stock.

L3 can vary between 120mm /5" – 2000mm/79". Draglinks are made to specification and are adjustable by 20mm/0.78" upon installation. The draglink should not exceed an angle of 5° from the horizontal.

A standard Cobra™ installation can accommodate a rudder rake up to a maximum of 30°. However this does depend on the boat size and type and the length of L3. If the angle exceeds 20°, please consult our Lewmar representative. As standard, all levers are mounted to the starboard side and the pedestal is mounted forward of the rudder stock.

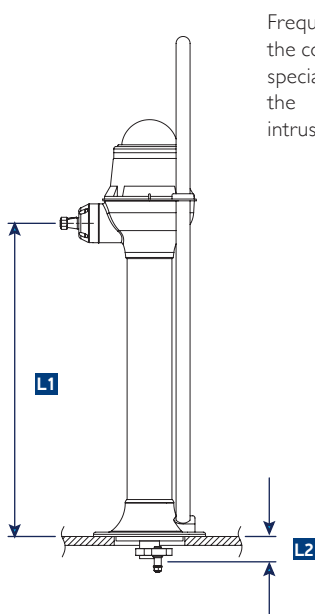

Frequently the space directly below the cockpit floor is limited and this special bearing arrangement reduces the intrusion into the accommodation.

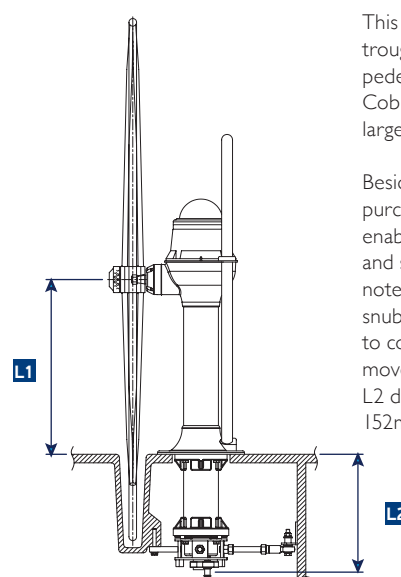

This illustrates the use of a wheel trough and shortened height pedestal, particularly common on Cobra™ Racing installations where large wheels are fitted.

Besides giving more mechanical purchase, the large diameter wheel enables the helmsman to sit out and still reach the helm. Please note that the use of a torque snubber plate may be necessary to counteract the extra pitching movement caused by the large L2 dimensions (greater than 152mm/6").



## Cobra™ Racing

4:1 gear ratio provides the ultimate in feel and responsiveness.

- Incorporates reinforced components to handle the higher torque demands of a large wheel installation
- More direct gear ratio offering 1.5 turns lock to lock
- Can be reduced to less than 1 turn when required
- Larger diameter pinion for greater strength and more direct steering
- Light, strong pedestal shell incorporating 101mm/4" diameter tube
- Optimised gear quadrant in super nickel aluminium bronze.



## Cobra™ Ocean

6.7:1 Gear ratio for Blue Water yachts, with smaller wheels requiring a greater number of turns lock to lock.

- For yachts up to 18m/60'
- Suitable for maximum rudder torque of 4905Nm/3618 lb ft
- Additional space for a larger gear set
- 2.4 turns lock to lock
- Larger bearings and a 60mm/2.3" stainless steel down shaft
- Royale and Ranger pedestals specific to the Cobra™ Ocean system

## 9. Steering



### Cobra™ Systems

#### Cobra™ System – Customised for installations

A Cobra™ system can be customised for twin rudder installations, bridge deck consoles, transom-mount rudders and centre-cockpit vessels. Cobra™ offers a simple steering solution for this layout that ensure the rudders remain in phase and Ackerman effect can be achieved.

- One-piece power input assembly, easy maintenance and gear adjustment
- High-efficiency double sealed deep groove ball bearings
- Powerful and progressive, front mount friction brake
- One-piece heavy duty stainless steel down tube
- Computer optimised gear quadrant design
- Gear quadrant secured via twin 10mm/0.39" stake pins with double shear
- High-strength stainless steel output level welded to down shaft
- Stainless steel rose jointed draglink

#### Rack & Pinion Base unit

- Remote mountable rack & pinion gearbox
- Suitable for yacht up to 13.7m / 45'
- Direct gear ratio provides 1.77 turns lock to lock with 181 chain drive
- CE certified

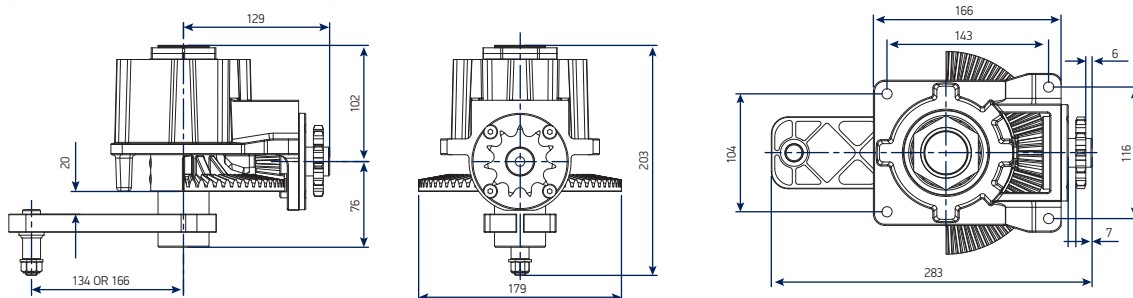



## Cobra™ Spares and Accessories

### Stop Rings

Limiting the amount of rudder travel is essential on all steering arrangements. The Cobra™ system provides an alternative and simpler to install device than conventional rudder stops – the stop ring.

The stop ring, mounted directly below the pedestal, ensures that the output lever travel does not exceed the designed limit. Stops should operate adjacent to operating centres.

Note: Additional rudder stop can be fitted to tiller lever if a stop ring cannot be installed.

PART NO.	DESCRIPTION
8900006-***	STOP RING COBRA

\*Customer must specify limiter angle

### Rod Ends

PART NO.	DESCRIPTION
82000356	ROD END AHFT10 STAINLESS STEEL
82000357	ROD END AHFT12 STAINLESS STEEL

Rods ends can be purchased separate from draglink assemblies as spare parts.



Rod Ends

### Draglinks

PART NO.	DESCRIPTION	LENGTH ONE END LOOSE		SYSTEM TYPE
		MM	IN	
89500011	DRAGLINK ASSEMBLIES AHFT 10	1000	40	CRUISING
89500012	DRAGLINK ASSEMBLIES AHFT 10	2000	80	CRUISING
89500013	DRAGLINK ASSEMBLIES AHFT 12	1000	40	RACING AND OCEAN
89500014	DRAGLINK ASSEMBLIES AHFT 12	2000	80	RACING AND OCEAN

The draglinks specified above are supplied with one end fitting loose to enable the tube to be cut to size and welded. If the correct centres for the draglink are known contact your Lewmar dealer prior to order for the part number relating to the centre required.



Draglink complete with rod end

### Tiller Levers

Lewmar also offers extended versions to enable the fitting of linear drive type autopilots at 250mm/10" and 350mm/13" centres, in conjunction with the standard 203mm/8" position for the steering draglink.

PART NO.	CAN BE MACHINED TO BORE SIZE		DESCRIPTION
	MM	IN	
89500002	80	3	TILLER LEVER
89500005	100	4	TILLER LEVER
89500008	125	5	TILLER LEVER

All above part numbers are for standard tiller levers supplied pilot bored at 25mm. Lewmar offer a machining service to supply the tiller lever ready to suit the rudder stock of the boat, please contact your Lewmar distributor for part number and price prior to ordering.

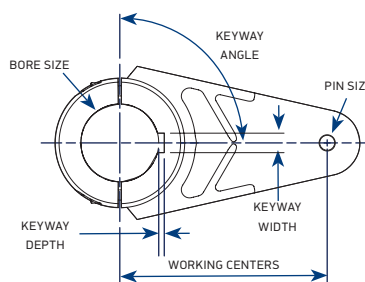

## 9. Steering



### Mamba™ Systems

The Mamba™ system provides the ultimate in marine steering, in terms of precision, feedback and strength. Mamba™ systems are chosen for a diverse range of sail and power craft such as bluewater cruising yachts, pilot vessels, and sail training vessels.

- Uses rotating torque tubes and bevel gears to transmit the helmsman's input
- Reduction gearboxes can be incorporated in the system to reduce the load felt on the wheel
- Allows twin wheels and multiple rudder applications
- Favoured for its direct feel with almost zero backlash
- Autopilots can be coupled directly into the system giving added flexibility of setup
- Minimal maintenance
- Offers precise rudder feel
- Different gearbox options accommodate high rudder torques seen on larger boats





## Principle of Operation

Mamba™ steering is a rotating torque tube and bevelhead system, transmitting the helmsman's input to a high efficiency reduction gearbox, mounted adjacent to the rudder stock. A tiller lever is fitted to the rudder stock and is driven by a similar lever integral to the gearbox, via a fully articulating jointed draglink.

Two or three station systems, catamarans and tandem wheel steering systems are regularly supplied. The integration of autopilot drives and remote controlled disengagement units is simply achieved.

The Mamba™ range of steering systems is offered in two sizes, BH10 and BH130, which are coupled with 12 models of reduction gearbox, providing equipment to suit all craft from 10.6m/35ft to 61m/200ft. In most cases, either high efficiency spur, or reduction gearboxes are chosen, offering between 1.0 and 2.6 turns lock to lock. Each option also provides a high reverse efficiency, transmitting rudder feel to the helmsman.

To simplify installations, Mamba™ equipment offers the following examples of versatility:

- Bevelheads can be supplied with 2, 3 or 4 steering shafts, permitting integration for secondary steering stations, tandem wheel arrangements and direct coupled autopilot drives.
- A choice of mounting plates and brackets for bevel and gearboxes.
- Availability of step ratio gears to adjust overall steering ratio.

The lever geometry for Lewmar transmission systems is based on the principle of Wide Angle Geometry.



## 9. Steering

### Mamba™ – Bevelheads

#### BH10

Lewmar BH10 torque tubes are made of marine grade stainless steel depending on the specific installation requirements. Torque tubes are supplied in standard lengths with one end loose for welding by the installer. Or we offer fully welded torque tubes to pre-specified lengths.



#### BH130 – For boats 60ft and above

Lewmar BH130 torque tubes are made of marine grade stainless steel. Depending on the specific installation requirements, torque tubes are supplied in standard lengths with one end loose for welding by the installer. Or we offer fully welded torque tubes to pre-specified lengths.



#### Additional information

- 1 Steering shafts can be made to customer's preferred length
- 2 Bevelheads are available with either rotation
- 3 Standard bevelheads have 1:1 ratio, but other ratios are available as detailed in specification
- 4 Mounting plate (or bracket) can be fitted to all faces to facilitate ease of mounting
- 5 All bevelheads can be configured to accept the Lewmar direct fit autopilot mount
- 6 For detailed dimensions contact a Lewmar representative
- 7 Due to the custom nature of this product, contact Lewmar for part number

### Universal Joints

Must be fitted at both ends of a torque tube. Where a self aligning bearing is used, one universal joint connects both torque tubes, as shown in illustrations. Self aligning bearings work up to an angle of 15°. AMK10 universal joints have a maximum permissible working angle of 25°. Where practical, the angle at each joint should be balanced.

The WUJ6 universal joint is suitable for use with large gearboxes 18, 20 and 45, see p191.

It has a maximum permissible working angle of 25°. Where practical, the angle at each joint should be balanced.



Mamba Universal Joint and self-aligning bearing

### Mamba™ – BG Reduction Gearboxes

The BG Series of high efficiency reduction gearboxes employ bevel gears manufactured from either high alloy steel or nickel bronze alloy running in precision roller bearings. Gear casings are manufactured from marine grade aluminium and shaft work is stainless steel or nickel bronze alloy. All gearboxes are grease filled and shimmed for zero backlash.

MECHANICAL GEARBOX TYPE	GEAR RATIO	ADVANTAGE AT MIDSHIPS	TURNS HO TO HO	MAXIMUM RUDDER TORQUE		TYPICAL BOAT RANGE	
				NM	FT.LBS	M	FT
BG12	5:1	8:1	1.8	2943	2170	UP TO 14	UP TO 45
BG12/2	5:1	8:1	1.8	2943	2170	UP TO 14	UP TO 45
BG30	6.7:1	10.2:1	2.4	4905	3617	14-18	45'-60'

#### Additional information

- 1 Mechanical advantage and turns lock to lock are based on standard lever geometry
- 2 Reduction gearboxes can be mounted anywhere within the general proximity of the rudder stock 0.2m/7" to 2m/6.5'
- 3 For detailed dimensions contact your Lewmar representative



89200034  
Gearbox (BG12)

## Mamba™ – WRG Reduction Gearboxes

The WRG series of high-efficiency gearboxes employs precision cut, stub tooth form, spur gears running in deep groove ball and roller bearings. Gear casings are manufactured from marine grade aluminium, and shaft work is in stainless steel or nickel bronze alloy. All gearboxes are CNC machined and grease filled to ensure a perfect fit and maintenance-free life.



89200041  
Gearbox (WRG12)



89200046  
Gearbox (WRG18)

### Additional information

- 1 Mechanical advantage and turns lock to lock are based on standard lever geometry
- 2 Overall mechanical advantage and turns lock to lock can be altered via stepped ratio bevels in bevelheads within the system or by non-standard lever centers.
- 3 Reduction gearboxes can be mounted anywhere within the general proximity of the rudder stock (0.2m/7" to 2m/6.5') For more details please refer to the installation and maintenance handbook.
- 4 Bevelheads can be directly integrated to all WRG series gearboxes
- 5 For detailed dimensions contact your Lewmar representative.

MECHANICAL GEARBOX TYPE	GEAR RATIO	ADVANTAGE AT MID-SHIPS	TURNS HO TO HO	MAXIMUM RUDDER TORQUE		TYPICAL BOAT RANGE	
				NM	FT.LBS	M	FT
WRG11	5:1	8:1	1.8	2943	2170	11.5-14	38-45
WRG12	7:1	10.8:1	2.4.8	5450	3798	13-20	45-65
WRG18	10:1	15.2:1	3.5	10800	7965	18-27	60-90
WRG20	12.6:1	19.1:1	4.4	13700	10104	24-33.5	80-110
WRG45	13:1	20:1	4.6	24000	17701	20-46	90-120
WRG60	24.7:1	37.5:1	8.6	36250	26740	33-45	110-150
WRG90	65:1	96:1	21.6	53000	39090	36.5-61	120-200

## Mamba™ – Bevelhead Integration

Integration – WRG series of spur reduction gearboxes can be supplied with an integral bevelhead fitted to the input shaft as per illustrations below. The bevelhead can be mounted to either side of the reduction gearbox and rotated at any angle. Custom arrangements are available with greater stand offs between the gearbox and bevelhead.

### Pedestal Gearbox Integration

Mamba™ pedestal – BG WRG Integration – For larger aft cockpit yachts, the WRG and BG series gearboxes can be directly mounted to the pedestal.

On the WRG12 gearbox and above – a torque adapter plate is provided to transmit the force directly to the underside of the cockpit floor.

For raked rudders (25° and above), it is normal to use the BG series of gearbox.

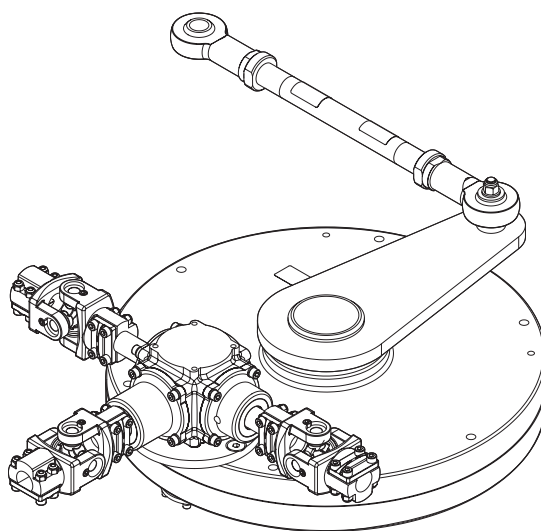

Gearbox WRG type showing directional movement of outer lever and torque tubes

## 9. Steering



### Cassette Steering System

Light in weight and low maintenance, Lewmar's revolutionary cassette steering system is an innovative blend of our broad product experience. Constellation™ wire extends from the pedestal and connects to our proven, marine-grade, ball bearing traveller car and track. Using the components of the Mamba™ solid system, the track and car are connected to the rudder blades. The entire system is lightweight with multiple mounting possibilities and responsive feedback when sailing.

- Multi-directional track configuration
- Wire from pedestal to car, torque tube to tiller lever
- Space saving due to mounting
- Lightweight and robust technology developed specifically for sailors
- Incredibly low friction using marine-proven ball bearing equipment
- Designed for use with tandem systems

Used in the Dufour 310 and Hallberg Rassy 340, this system provides a new steering solution that combines the reliability and response of the Mamba™ system with the high-specification technology of Lewmar hardware.

Contact your Lewmar representative for more information.



# Rudder Bearing Solutions

Lewmar's rudder bearings come in two basic type – plain roller and self-aligning roller. We can provide a rudder bearing solution for any yacht, whether it is tiller steer or a Grand Prix racer.

## Typical Bearing Installation

- A. Lower bearings should be positioned so that the seals are above the water line. A gaitor may also be used for added security against leaks.
- B. Upper and Lower bearings should be spaced apart as far as practically possible to reduce loading on the rollers.
- C. A removable deck cover may be used for quick fitting of an emergency tiller.
- D. For tiller steered yachts seals may be incorporated into the upper bearing to prevent water ingress from above deck into the boat.

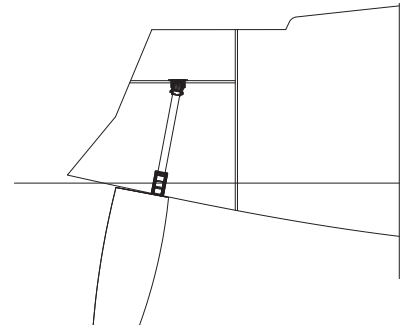

## Upper Bearings

- Manufactured in 6082 aluminium and anodised
- Suit rudder stock diameters 50-109mm (2-4 5/16 in)
- Easy to install flanged housing

- Model with a deck cover offers integral locking ring and vertical thrust race
- No grease or maintenance required

## Plain roller bearings

Features precision Delrin rollers with low friction co-efficient.

Illustration shows a plain roller bearing with deck cover and thrust race.



## Self-aligning roller bearings

Bearings includes self-aligning ball and precision Delrin rollers.



## Lower Bearings

- Suit rudder stock diameters 50mm-109mm (2-4 5/16 in)

- No grease or maintenance required

## Aluminium roller bearings

- Manufactured in 6082 aluminium and anodised
- Accepts sealing system for lip seals or rudder tube and gaitor
- Low friction co-efficient
- Available in self-aligning version



## Locking Rings

- Used with upper bearings without integral locking ring
- Manufactured in 6082 aluminium and anodised
- Suit rudder stock diameters 40mm-110mm ( 1 1/2" – 4 5/16")
- Stainless set screws secure locking ring to rudder stock

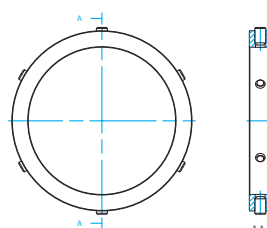

## Lip Seals

- Precision fit seals provide protection against water ingress with minimal friction
- Can be used in conjunction with a gaitor for added protection
- Sizes available to suit any rudder stock diameter
- Manufactured in tough polyurethane material

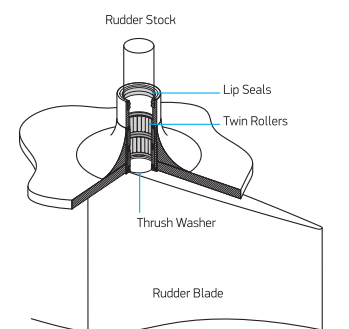

## 9. Steering



### Wheels

- Choice of wheels to suit any application
- 25mm/1" tapered keyed shaft ensures positive fit
- Compatible with all Lewmar Steering Systems
- Full range of accessories available



### Wheel Selection Guide

	WHEEL DIAMETER									
CM	66	81	97	112	127	142	157	173	188	
IN	26	32	38	44	50	56	62	68	74	
FOLDING WHEEL										
COMMODORE FLAT										
COMMODORE DISHED										
MINI MAXI										
CARBON										
FASTNET										

### The Lewmar Steering Wheel Shaft

All Lewmar wheels listed in this catalogue have the 25mm/1" taper shaft. Angle of taper ensures the wheel is positively fit and easily removable. Larger wheels (1.6m and up) can also be supplied with the 30mm/1 3/16" taper shaft. The folding wheel dual-hub also fits a 25mm/1" parallel shaft.

#### 25mm Taper Shaft

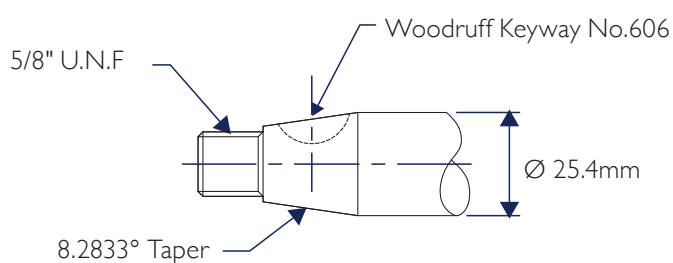

#### 30mm Taper Shaft

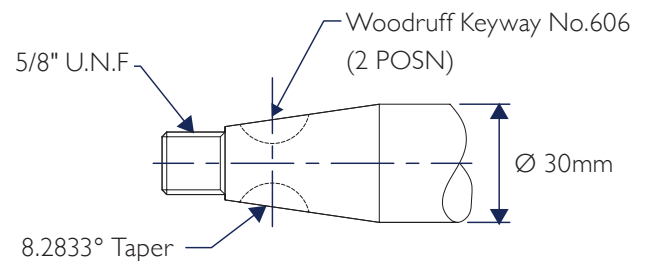



## Folding Wheel

Reclaim space in your cockpit with Lewmar's patented Folding Wheel.

The Folding Wheel has a two-turn, buttress-threaded, split-spoke design, and a unique hinging system with fast-action handgrip release. This allows you to easily fold and unfold the wheel, using a simple twist of the composite handgrip. At a fraction of the cost of custom versions, the Folding Wheel is appealing to both production boat builders and owners looking to improve their deck layouts.

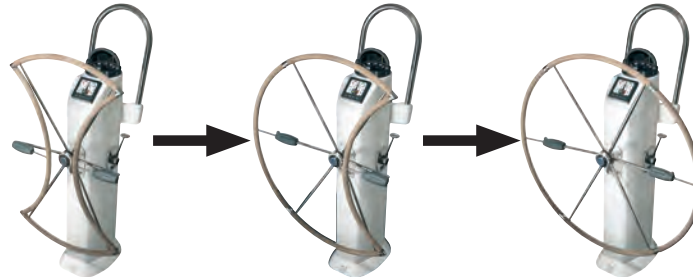

PART NO.	DESCRIPTION	SIZE		FITS SHAFT	FOLDED WIDTH	
		MM	IN		MM	IN
89700375	FOLDING WHEEL WITH HIDE COVER	813	32	1" TAPER	487	19
89700376	FOLDING WHEEL WITH HIDE COVER	914	36	1" TAPER	547	21.5
89700377	FOLDING WHEEL WITH HIDE COVER	1016	40	1" TAPER	605	24
89700520	FOLDING WHEEL WITH HIDE COVER	1066	42	1" TAPER	634	25
89700406	FOLDING WHEEL WITH HIDE COVER (DUAL HUB)	813	32	1" TAPER @ 1" PARALLEL	487	19
89700407	FOLDING WHEEL WITH HIDE COVER (DUAL HUB)	914	36	1" TAPER @ 1" PARALLEL	547	21.5
89700408	FOLDING WHEEL WITH HIDE COVER (DUAL HUB)	1016	40	1" TAPER @ 1" PARALLEL	605	24
89700521	FOLDING WHEEL WITH HIDE COVER (DUAL HUB)	1066	42	1" TAPER @ 1" PARALLEL	634	25

## The Commodore™ Wheel

Durable and elegantly styled, the Commodore is a standard choice for yachtsmen the world over.

Choose from sizes ranging in diameter from 66cm (26") to 122cm (48").



PART NO.	DESCRIPTION	SIZE	
		MM	IN
89700264	FLAT 5 SPOKE WITH HIDE COVER	660	26
89700265	FLAT 5 SPOKE WITH HIDE COVER	710	28
89700266	FLAT 5 SPOKE WITH HIDE COVER	760	30
89700267	FLAT 5 SPOKE WITH HIDE COVER	810	32
89700268	FLAT 5 SPOKE WITH HIDE COVER	910	36
89700297	DISHED 5 SPOKE WITH HIDE COVER	660	26
89700298	DISHED 5 SPOKE WITH HIDE COVER	710	28
89700299	DISHED 5 SPOKE WITH HIDE COVER	760	30
89700300	DISHED 5 SPOKE WITH HIDE COVER	810	32
89700301	DISHED 5 SPOKE WITH HIDE COVER	910	36
89700593	DISHED 5 SPOKE WITH HIDE COVER	1020	40
89700024	FLAT 8 SPOKE WITH HIDE COVER	1070	42
89700025	FLAT 8 SPOKE WITH HIDE COVER	1220	48
89700063	DISHED 8 SPOKE WITH HIDE COVER	1070	42
89700064	DISHED 8 SPOKE WITH HIDE COVER	1220	48

## The Mini Maxi™ Wheel

PART NO.	DESCRIPTION	SIZE	
		MM	IN
89700092	MINI MAXI™ 10 SPOKE	910	36
89700093	MINI MAXI™ 10 SPOKE	1020	40
89700094	MINI MAXI™ 10 SPOKE	1070	42
89700095	MINI MAXI™ 10 SPOKE	1220	48
89700096	MINI MAXI™ 10 SPOKE	1320	52
89700097	MINI MAXI™ 10 SPOKE	1370	54
89700098	MINI MAXI™ 10 SPOKE	1520	60
89700063	8 SPOKE DISHED, POLISHED	1070	42
89700064	8 SPOKE DISHED, POLISHED	1220	48

The Mini Maxi™ wheel is designed for use where a larger wheel is required or for exceptional rigidity.

- Available up to 1524 mm/ 60" diameter
- Supplied with hide cover and spats



## 9. Steering



### Custom Wheels

#### Y-Spoke Carbon Wheel

Lewmar manufactures a range of custom wheels. The Y-Spoke Carbon Wheel combines ultimate weight saving with sleek and slender styling.

Ideal for Grand Prix race yachts or as a solution to increasing demand for race technology on cruising yachts. These wheels are built and supplied to order in a variety of sizes ranging from 1m/39" to 1.8m/71".



#### Fastnet Wheel

The lightweight and stylish Fastnet Wheel is made from Aluminium 6082. The wheels are supplied powder-coat painted, or with leather stitched to the wheel rim in a range of colours.

The Fastnet wheel range starts at 1.22m/48" with incremental sizes up to 1.75m/69".



#### Other Custom Wheels

Lewmar designs custom wheels to fit a pedestal specific to the customer's requirement.

3D modelling is used to ensure that the wheel fits first time, even in tight spaces.



Custom carbon wheels



Custom dished wheel designed to mount on the back face of the customer's own pedestal for which they have a registered trademark.

# Wheel Accessories

## Multi-Tooth Wheel Disengagement Units

This is a quick, safe and efficient way to disengage the steering wheel whilst still allowing the system to operate. This is particularly useful when using a dual wheel system or operating the steering by Autopilot. The unit incorporates precision multi tooth gears to ensure zero backlash or play.



Note: This product cannot be retrofitted to an existing wheel and must be requested when ordering a new wheel. This multi-tooth disengagement unit can be added to any style newly built Lewmar wheel. For prices and part numbers of wheels incorporating this product please speak to a Lewmar representative.

## Brake Spinner

A brake spinner is used to lock the wheel and rudder when in port or at anchor.

- Lewmar uses a powerful and progressive through shaft friction brake
- Specific to the type of wheel used

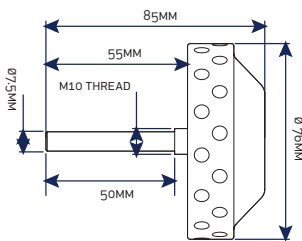

Ref: 8910 0143

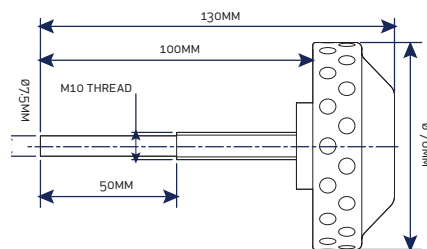

Ref: 89100144



PART NO.	FINISH	FOLDING/COMMODORE WHEEL	MINI MAXI WHEEL	CARBON
89100143	STAINLESS STEEL	✓		
89800053	WHITE COMPOSITE	✓		
89100144	STAINLESS STEEL		✓	
89800123	STAINLESS STEEL			✓

## Rail Mount Wheel Holder

The Rail Mount Wheel Holder can be used on most boat rails to store the wheel when not in use, thus providing a clear area in the cockpit.

- Manufactured in 316 investment cast Stainless Steel
- Designed to suit 25mm/1" taper or Parallel steering wheel shaft
- Will fit 25mm/1", 28.6mm /1 1/8" & 32mm/1 1/4" diameter rails



89400327

Rail Mount Wheel Holder

## Quick Release Bi-square Wheel Nuts

The quick release wheel nut – with a standard winch handle bi-square. As you always have a winch handle on hand, this is a quick and simple way to remove your wheel. The quick release wheel nut is available in 316 grade stainless steel, to mirror polish finish.

PART NO.	TO SUIT WHEEL TYPE
89700161	COMMODORE™ WHEEL
89700162	MINI MAXI™ FASTNET/CARBON



## 9. Steering



### Powerboat Wheels

The range features 3-spoke design, constructed in 316 stainless steel for the welded and cast wheels or carbon fibre. Cast and carbon rims are enhanced with integrated moulded rubber grips for comfort and positive tactile control. Each wheel is also supplied with a pre-installed ball-raced Power Grip.



#### SWR Range - Stainless steel welded rim

##### Key features

- Polished oval shaped tubular rim with formed rear face grip
- Cast spokes with integrated hub
- 316 stainless steel construction for durability
- Deep dish design for extra room and comfort
- Non-magnetic
- Pre-assembled with ball-raced Power Grip for ease of use

##### Specifications

- Rim material: 316 Stainless Steel
- Spokes: Three
- Rim diameters: 13.5" (340mm) and 15.5" (390mm)
- Hole diameter: 3/4" Taper
- Dish: 19 degrees (13.5") and 17 degrees (15.5")



#### SCR Range - Stainless steel cast rim

##### Key Features

- Polished oval shaped rim
- Rear face EVA moulded insert grips
- 316 stainless steel cast construction for durability
- Deep dish design for extra room and comfort
- Non-magnetic
- Pre-assembled with ball-raced Power Grip for ease of use

##### Specifications

- Rim material: 316 Stainless Steel
- Spokes: Three
- Rim diameters: 13.5" (340mm) and 15.5" (390mm)
- Hole diameter: 3/4" Taper
- Dish: 22 degrees (13.5") 19 degrees (15.5")
- Finish: Polished Stainless, Satin Silver or Black





## CFR Range - Carbon Fibre rim

### Key Features

- High-strength and low weight Carbon fibre construction
- High-gloss UV-resistant lacquered finish
- Rear face EVA moulded insert grips
- Deep dish design for extra room and comfort
- Non-magnetic
- Centre hub insert machined from solid billet 316 stainless steel
- Pre-assembled with ball-raced Power Grip for ease of use

### Specifications

- Rim material: Carbon Fibre
- Spokes: Three
- Rim diameters: 13.5" (340mm)
- Hole diameter: ¾" Taper
- Dish: 22 degrees (13.5")



## Power Grip

Introducing the new Power Grip from Lewmar: a power boat wheel handle with a Rolex-style lid which can be fitted onto the wheel for further precision and more tactile mooring. They can be either bolted or clamped onto the wheel with two clamping points by an allen wrench, included in the Power Grip kit.

- Fitted with two clamps or bolted
- Rolex style lid
- Allen wrench included
- Twin ball bearing race



PART NO.	DESCRIPTION
89700862	POWER GRIP KIT

## 9. Steering



### Powerboat Wheels

#### SWR Welded St/St Wheel 13.5"/15.5"

PART NUMBER	DESCRIPTION
89700871	PG WHEEL 13.5" WELDED NUT 5/18
89700821	PG WHEEL 13.5" WELDED NUT 1/2
89700822	PG WHEEL 13.5" WELDED NUT M12
89700823	PG WHEEL 15.5" WELDED NUT 5/18
89700824	PG WHEEL 15.5" WELDED NUT 1/2
89700825	PG WHEEL 15.5" WELDED NUT M12

#### CFR Carbon Wheel 13.5"

PART NUMBER	DESCRIPTION
89700924	PG WHEEL CARBON + NUT 5/8
89700864	PG WHEEL CARBON + NUT 1/2
89700865	PG CARBON WHEEL + NUT M12

#### Service / Spares Kits

PART NUMBER	DESCRIPTION
89400470	PG 5/8" UNC NUT & WASHER KIT
89400471	PG 1/2" UNC NUT & WASHER KIT
89400479	PG M12 NUT & WASHER KIT
89400472	PG BALL BEARING SERVICE KIT
89400473	PG REPLACEMENT LID KIT
89400475	PG WHEEL 13.5" RUBBER REPLACEMENT (X3)
89400476	PG WHEEL 15.5" RUBBER REPLACEMENT (X3)

#### SCR-3 Cast St/St 3-Spoke Wheel 13.5"/15.5"

PART NUMBER	DESCRIPTION
89700827	PG WHEEL 13.5" ST/ST 3-SPOKE NUT 5/18
89700828	PG WHEEL 13.5" ST/ST 3-SPOKE NUT 1/2
89700925	PG WHEEL 13.5" ST/ST 3-SPOKE NUT M12
89700909	PG WHEEL 13.5" ST/ST 3-SPOKE SATIN NUT 5/18
89700910	PG WHEEL 13.5" ST/ST 3-SPOKE SATIN NUT 1/2
89700911	PG WHEEL 13.5" ST/ST 3-SPOKE SATIN NUT M12
89700913	PG WHEEL 13.5" ST/ST 3-SPOKE BLACK NUT 5/18
89700914	PG WHEEL 13.5" ST/ST 3-SPOKE BLACK NUT 1/2
89700915	PG WHEEL 13.5" ST/ST 3-SPOKE BLACK NUT M12
89700830	PG WHEEL 15.5" ST/ST 3-SPOKE NUT 5/18
89700831	PG WHEEL 15.5" ST/ST 3-SPOKE NUT 1/2
89700926	PG WHEEL 15.5" ST/ST 3-SPOKE NUT M12
89700917	PG WHEEL 15.5" ST/ST 3-SPOKE SATIN NUT 5/18
89700918	PG WHEEL 15.5" ST/ST 3-SPOKE SATIN NUT 1/2
89700919	PG WHEEL 15.5" ST/ST 3-SPOKE SATIN NUT M12
89700921	PG WHEEL 15.5" ST/ST 3-SPOKE BLACK NUT 5/18
89700922	PG WHEEL 15.5" ST/ST 3-SPOKE BLACK NUT 1/2
89700923	PG WHEEL 15.5" ST/ST 3-SPOKE BLACK NUT M12





## Pedestals

Lewmar pedestals are manufactured from high-strength alloy or extrusion. The head design uses modern composites which guard against electrolytic action and the corrosive nature of salt water. Lewmar pedestals are a standard height, but custom pedestal heights are available upon request.

- All Lewmar pedestals are available in Constellation™, Cobra™ and Mamba™ steering systems.
- Guardrails are not included.
- Lewmar offers a comprehensive range of pedestal accessories and options from guardrails and engine control to compasses, cockpit tables and instrument pods.

### Pedestal Selection Guide

PEDESTAL	AFT COCKPIT					CENTRE COCKPIT		TILLER-WHEEL COVERIONS	
	FOR BOATS UP TO 60FT CONSTELLATION	FOR BOATS UP TO 60FT COBRA	FOR BOATS UP TO 60FT COBRA	FOR BOATS UP TO 60FT COBRA	FOR BOATS UP TO 200FT MAMBA	FOR BOATS UP TO 80FT CONSTELLATION	FOR BOATS UP TO 80FT MAMBA	CONSTELLATION	MAMBA
ENGUARD	•	•		•	•	•	•	•	•
INTEGRA		•		•	•	•	•	•	•
ROYALE	•	•	•		•	•	•		
MAXIMUM WHEEL SIZE	2 M (78 IN)	1.2 M (48 IN)	1.2 M (48 IN)	2 M (78 IN)	2 M (78 IN)	2 M (78 IN)	2 M (78 IN)	2 M (78 IN)	1.2 M (48 IN)

## Enguard Pedestal

The Enguard pedestal incorporates an integral guardrail pedestal base, which minimises the footprint area the pedestal takes up on the deck. The Enguard pedestal can be found fitted to many production boats around the world.

- Integrated guardrail base providing compact and rapid installation
- Wide range of accessories available
- Custom heights available

Enguard Pedestal Dimensions

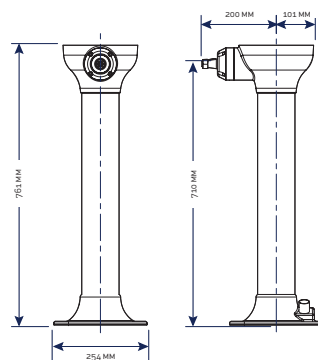

### Enguard Pedestal Part Numbers

Standard part numbers listed below. Many variations available, contact your Lewmar representative for more information

PART NO.	DESCRIPTION
89900003	CONSTELLATION ENGUARD ANS150 11T
89900031	COBRA CRUISING OL10STB
89900046	MAMBA ENGUARD BH10 BRAKE

## 9. Steering

### Integra Pedestal

The Integra pedestal is the latest in Lewmar's range of integrated pedestal steering systems. The Integra offers quick and easy above deck access to fit Lewmar's patented autopilot drive motor.

The Integra pedestal can be found fitted to many production boats around the world.

- All Integra Cobra pedestals have the ability to install an integrated autopilot drive
- Harness bolts supplied as standard on the forward and aft side of the pedestal deck flange
- Compass mounting platform and integrated housing
- Ability to mount 1 single instrument to the uPVC top moulding
- Pre-installed single lever engine control
- Removable access door for quick and simple autopilot installation
- Pedestal pre-drilled for cockpit table mounting
- Pedestal stop ring included



### Integra Pedestal Dimensions

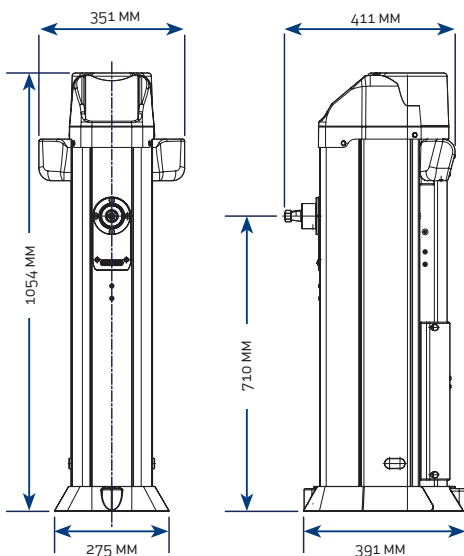

### Integra Pedestal Part Numbers

Standard part numbers listed below. Many variations available, contact your Lewmar representative for more information

PART NO.	DESCRIPTION
89900014	CONSTELLATION ROYALE ANS150 11T
89900034	COBRA CRUISING ROYALE TMNT GUARDRAIL
89900052	MAMBA ROYALE BH10 BRAKE GUARDRAIL



## Royale Pedestal

The Royale is an evolution of the console style pedestal range. The Royale head provides maximum flexibility for instrument mounting.

The Royale pedestal can be found fitted to many production boats around the world such as Hallberg Rassy and Rustler Yachts.

- Mounting areas for single lever engine control on port or starboard
- Accepts 4 Industry standard 110mm / 4.25" yachting instruments
- Flush mount compass platform



### Royale Pedestal Dimensions

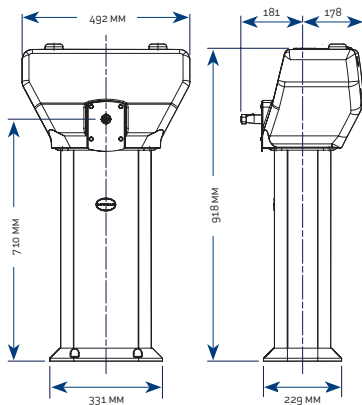

### Royale Pedestal Part Numbers

Standard part numbers listed below. Many variations available, contact your Lewmar representative for more information

PART NO.	DESCRIPTION
89900302	CONSTELLATION INTEGRA 11T 5-8P
89900299	COBRA CRUISING INTEGRA 0L10 L2 102L
89900306	MAMBA INTEGRA BH10 CU

### Custom Pedestal

Gunfleet *Flightdeck*

For the Gunfleet 43 project, Lewmar designed and specified all of the internal components to fit the customer's own pedestal.



### Bavaria Pedestal

- Custom steering pedestals designed for the Bavaria range of twin helm yachts.
- The GRP head can easily be trimmed to fit the customer's choice of instruments.
- Aluminium base provides excellent strength and rigidity with minimal weight.



# 9. Steering

## Guardrails

Lewmar Guardrails are designed to protect the compass and pedestal with also providing assistance while moving about the cockpit. Our wide range of straight, kickback and extended guardrails, are manufactured from 32mm/1.25" heavy duty 316 stainless steel tube. The extensive choice of guardrails is complemented by our instrument pod range.



### Enguard Guardrail kits

Enguard Guardrail Kits include: Guardrail (straight, kickback or extended kickback), Engine Pod, Top Plate & Cup holder

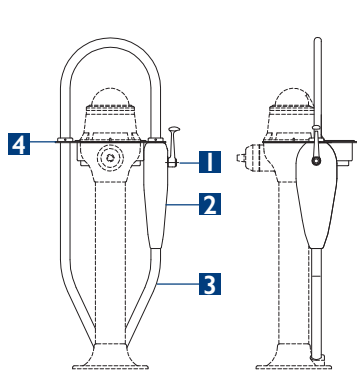

Straight Enguard Guardrail Kit  
89400298

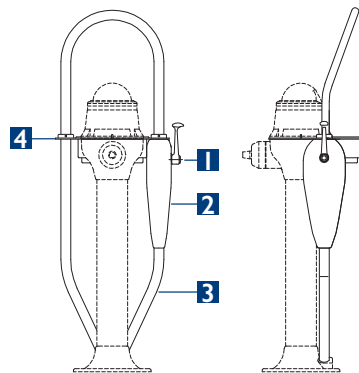

Kickback Enguard Guardrail Kit  
89400125

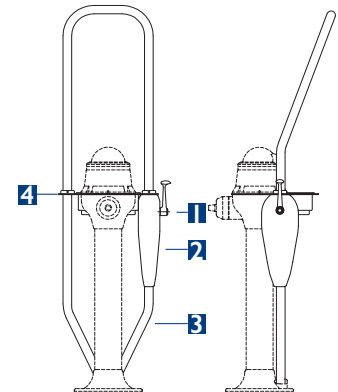

Enguard extended kickback guardrail kit  
89400299

### Enguard Guardrail Spares

PART NO.	DESCRIPTION	KEY
89400031	GUARDRAIL STRAIGHT (STBD)	
89400033	GUARDRAIL KICKBACK (STBD)	
89400035	GUARDRAIL EXTENDED KICKBACK (STBD)	
89400109	CONTROL MECHANISM	1
89400084	ENGINE POD	2
89400120	DROP TUBE	3

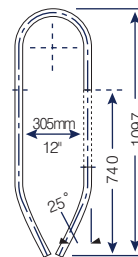

89400031

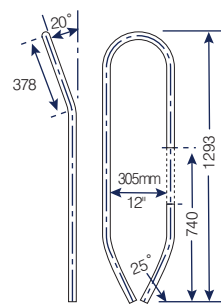

89400033

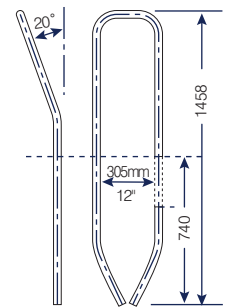

89400035

### Royale Guardrail

PART NO.	DESCRIPTION
89400046	KICKBACK GUARDRAIL
89400047	EXTENDED KICKBACK GUARDRAIL

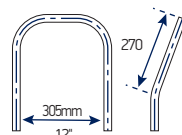

89400046

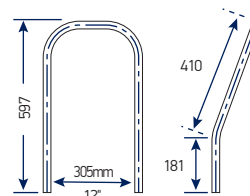

89400047

## Instrument Pods

### Helm Pod

With great new design features, the Lewmar Helm Pod is a perfect choice for all cockpit configurations.

- Range of models to fit up to 15" displays with options to install a combination of instruments and displays at the helm.
- Universal Helm Fixing fits pedestal rails from 25mm to 33.7mm (0.98" – 1.33"). Using a unique clamping system, the Pod can fit rail widths from 178mm (7") upwards.
- Secure & Watertight Install - Saddle system supports the stainless tubing enabling a secure and rigid fit onto any pedestal and also ensures a watertight seal at cable entry
- No Drill Fixing Kit- Customised U-bolts fit around rail and through the saddles into the back of the pod eliminating the need for time consuming and awkward drilling of the stainless rail.
- Hassle Free Install & Service- Fixings fit from back to front cutting their threads into injection moulded ABS inserts designed into the Pod front.
- Supplied Uncut

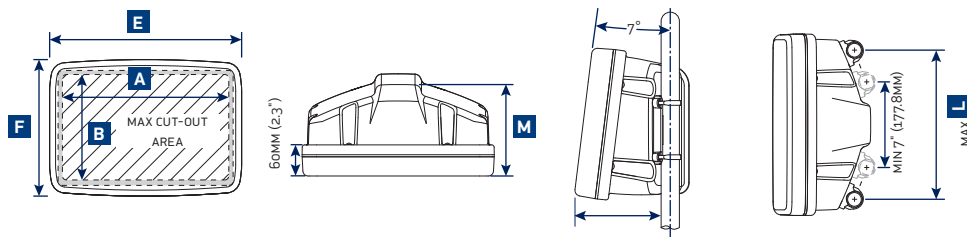

PEDESTAL GUARD SHOWN HAS 12" CENTRES

PART NO	DESCRIPTION	A		B		E		F		J		K		L		M	
		MM	IN	MM	IN	MM	IN	MM	IN	MM	IN	MM	IN	MM	IN	MM	IN
89400423	UP TO 8" DISPLAY	312	12.3	200	7.9	371	14.6	264	10.4	152	6.0	165	6.5	304.8	12.0	175	6.9
89400425	10@12" DISPLAY	365	14.4	241	9.5	424	16.7	304	12.0	186	7.3	192	7.6	304.8	12.0	175	6.9
89400427	15" DISPLAY	423	16.7	333	13.1	482	19.0	396	15.6	176	6.9	185	7.3	381	15.0	175	6.9
89400429	4 X STANDARD INSTRUMENTS	498	19.6	118	4.65	562	22.1	187	7.4	100	4.0	103	4.1	406	16.0	175	6.9
89400430	SYSTEM POD	541	21.3	274	10.8	600	23.6	336	13.2	205	8.1	207	8.1	381	15.0	175	6.9

### Stainless Steel GPS/ Mobile Phone Holder

- Manufactured from 316 investment cast stainless steel
- Pod arm will fit 1", 1 1/8" and 1 1/4" diameter guardrail tubes
- All wiring of products mounted to the pod arm is hidden internally.



89400328

# 9. Steering

## Instrument Pods

### Flex Mount

- View your instruments from the perfect angle by using the Flex mount in combination with the Lewmar Helm Pod.
- The Flex-Mount System gives you more options for installing your electronics – simply clamp onto your existing rail or steering binnacle and install the Helm Pod as normal.
- Easy to use quick release lever – tilt display forward / back for improved instrument viewing
- Cables exit the back of the Pod and into the pedestal / rail using watertight grommet
- Fits 25mm (1") and 31mm (1 1/4") rail sizes and requires minimum of 60mm (2.4") of straight rail to mount
- Three models available to suit 203mm (8"), 254mm (10") and 304mm (12") Helm Pod

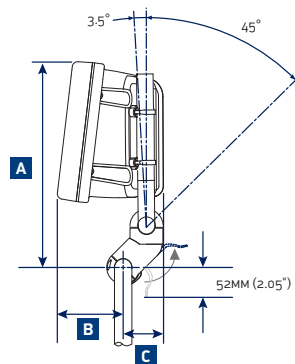

PART NO	DESCRIPTION	A		B		C	
		MM	IN	MM	IN	MM	IN
89400440	8" HELM POD	365	14.4	116	4.5	84	3.3
89400441	10 & 12" HELM POD	404	16.0	158.5	6.25	72	2.8
89400442	15" HELM POD	495	19.5	148.5	5.85	72	2.8

### Mast Pod



- The Mast Pod range offers a choice of sizes to allow installation of up to 4 standard or larger 20/20 maxi style instruments at the mast.
- Whether racing or cruising, our Mast Pods give you the best view of your instruments.

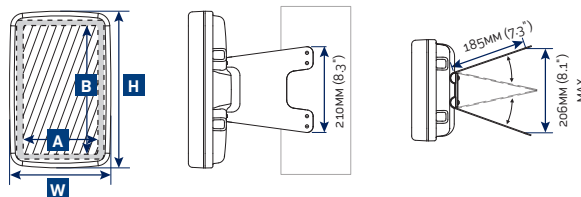

PART NO	DESCRIPTION	A		B		W		H	
		MM	IN	MM	IN	MM	IN	MM	IN
89400434	4 X STANDARD INSTRUMENTS	118	4.65	498	19.6	187	7.4	562	22.1
89400432	3 OR 4 X MAXI INSTRUMENTS	194.5	7.65	487	19.0	248	9.75	545	21.5

- Universal Mount – The range has been designed to fit mast sizes from 76mm (3") to 223mm (8.8"). Mast arms pivot about semi circular washers and an additional cross-brace provides stiffness preventing sideways movement.
- Increased Protection – Pod seal is manufactured from a high tear strength silicone.

### Classic Pod

- Fits directly to the Enguard and Classic style pedestals, via a special top plate.
- Offers increased mounting space for instruments, on the pedestal.
- Available with kickback guardrail for the inclusion of additional instrument pod options.
- Compass mounting point



89400100

## Deck Pod

- Solve the challenge of finding a level mounting surface to install your displays onto your powerboat, RIB or sailboat wheelhouse.
- Suitable for 203mm (8") to 381mm (15") display or an 8" display and 2 standard instruments
- Swivel & Tilt Base – One handed quick release action. Simply release the lever, swivel and tilt to suit your requirements before locking back into position
- Best viewing angle – An adjustable ball joint allows range of movement and multiple mounting angles
- Added Strength – Inner bracing plate secures the Deck Pod base to the pod and gives increased rigidity to the assembly eliminating potential damage from shock and vibration
- Increased Protection – Pod seal is manufactured from a high tear strength silicone.
- Supplied Uncut

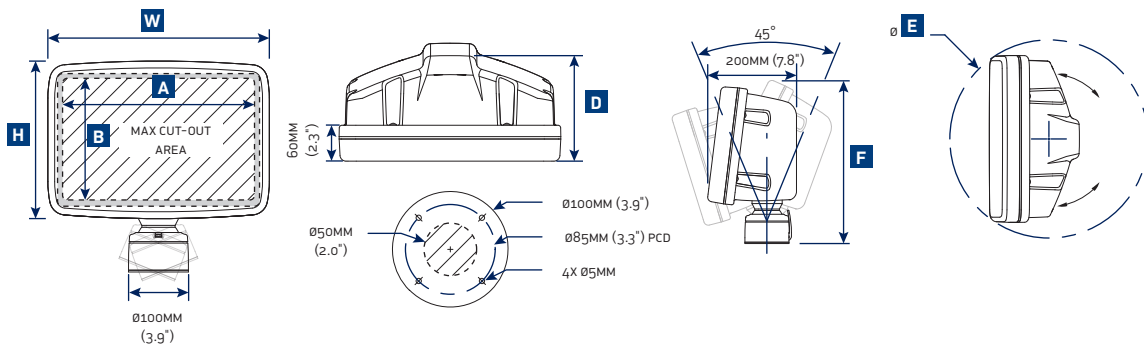

PART NO	DESCRIPTION	A		B		W		H		D		E		F	
		MM	IN	MM	IN	MM	IN	MM	IN	MM	IN	MM	IN	MM	IN
89400435	UP TO 8" DISPLAY	312	12.3	200	7.9	371	14.6	264	10.4	175	6.9	440	17.3	367	14.4
89400437	10" & 12" DISPLAY	365	14.4	241	9.5	424	16.7	304	12.0	175	6.9	485	19.1	404	15.9
89400439	15" DISPLAY	423	16.7	333	13.1	482	19.0	396	15.6	175	6.9	535	21.1	490	19.3

## Cockpit Table

PART NO.	DESCRIPTION
89400283	TABLE KIT FOR CLASSIC PEDESTAL UNVARNISHED
89400284	TABLE KIT FOR ENGUARD PEDESTAL UNVARNISHED
89400285	TABLE KIT FOR RELIANT/ATHENA PEDESTAL UNVARNISHED
89400286	TABLE KIT FOR ROYALE PEDESTAL UNVARNISHED
89400365	TABLE KIT FOR INTEGRA PEDESTAL UNVARNISHED
89400420	UNIVERSAL TABLE MOUNTING KIT TO SUIT ENGUARD, RELIANT, ROYALE AND INTEGRA PEDESTALS

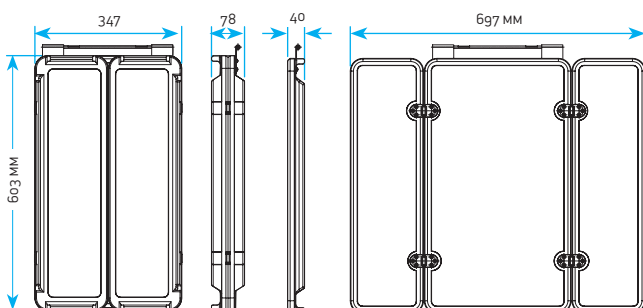

# 9. Steering

## Pedestal Accessories

### Compasses

The Lewmar 135 Compass is a stylish, precision instrument to complement any cockpit. The high-quality compass is manufactured with precision components. The compass utilises a real sapphire to ensure ultimate reliability and durability. The diaphragms, made of Viton®, are fully waterproof and absorb the fluid variations resulting from differing temperatures and air pressure. Every compass complies with rigorous vibration, temperature, stability and precision specifications.

- Apparent diameter of card: 130mm
- Unique ‘Lewmar’ binnacle
- Flush mounting or pedestal mounting (with the addition of a binnacle)
- Black card
- Minimal flushmount depth
- Double lighting (12 or 24 V mounting)
- 5 year warranty

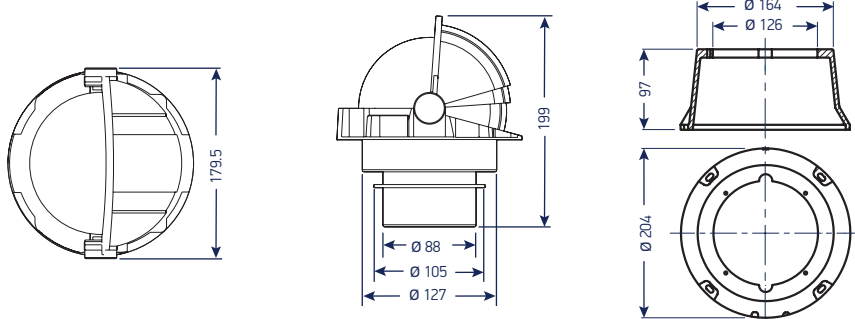

Lewmar 135 Compass flush mounted in pedestal

PART NO.	MODEL 135 COMPASS
89400000	FLUSH MOUNT 135 COMPASS WITH HOOD
89400001	135 COMPASS COMPLETE WITH BINNACLE HOUSING
89400002	BINNACLE ONLY

### Engine Control Mechanism

Lewmar offers engine and gear controls to complement the steering pedestal of your choice. The engine control designed exclusively for Lewmar is non-magnetic and can be guardrail or pedestal mounted without interfering with the compass.

- Housed in pod
- Guardrail Mounted
- Bulkhead mounted fascia plate
- Exclusive design for Lewmar
- Non-magnetic
- 316 stainless steel cranked handle



89800013

Rubber button plunger kit



89400136

Cranked Handle

PART NO.	DESCRIPTION
89400109	CONTROL MECH KIT CRANKED HANDLE AND FASCIA PLATE
89400133	FASCIA PLATE
89400136	CRANKED HANDLE STAINLESS STEEL
89400137	MECHANISM ONLY (NO HANDLE)
89400146	FITTING KIT FOR CONTROL MECHANISM
89800013	RUBBER BUTTON AND PLUNGER KIT
89400316	CONTROL MECHANISM CRANK HANDLE

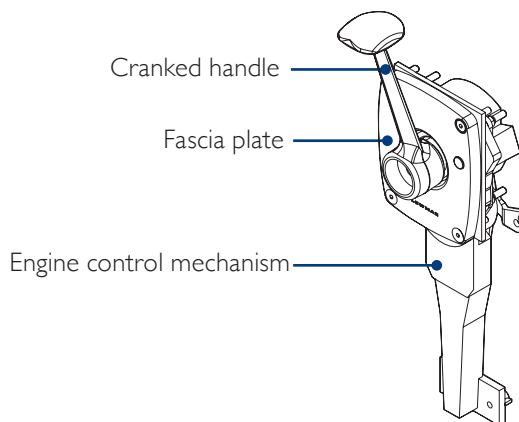



## Autopilot Drives

With many boats being sailed short-handed, it has become common practice to fit an autopilot drive. Our comprehensive range of autopilots are easily retrofitted and are designed to align perfectly with the boat's steering system.

- All units have an electromechanical clutch, virtually eliminating drag on the steering system
- All units are compatible with the majority of electronic suppliers, such as Raymarine, B&G and Simrad
- All drives have low current draw
- Drives available in 1/4, 1/2 and 1HP capacities, suitable for all Lewmar steering types.



## 9. Steering

### Integra Drives

The Integra drive is available in three formats. The Cobra™ and Mamba™ versions mount directly inside the Integra pedestal. This unique installation is only available from Lewmar and provides the installer with a simple and quick installation with no complicated, labour intensive mounting platforms required. We also offer an Integra Sprocket version, which is very popular with Bavaria Cruising yachts from 9m to 12m (30ft to 39ft) in length.



PART NO	DESCRIPTION
89300136	INTEGRA BASE DRIVE UNIT 12V
89300203	INTEGRA DRIVE FOR INTEGRA PEDESTAL

### Mamba™ Drives

These unique autopilot drives directly couple to Mamba™ systems, eliminating the need for separate platforms, chain and sprockets.



SPINE COUPLING CONNECTION	HP	VOLTAGE <sup>1</sup>	MAX OUTPUT TORQUE		SPEED RPM	MAX RUDDER TORQUE		AVE CURRENT CONSUMPTION	WEIGHT	
			NM	FT. LB		MKG	FT. LB		KG	LB
3/4 × 48	1/4	12	169	125	10	248	1794	4A	9.0	19.8
3/4 × 48	1/4	24	169	125	10	248	1794	2.5A	9.0	19.8
3/4 × 48	1/4	24	169	125	10	248	1794	2.5A	9.0	19.8
3/4 × 48	1/2	24	183	135	13	426	3080	3.5A	10.5	23.1
3/4 × 48	1/2	24	183	135	13	426	3080	3.5A	10.5	23.1

<sup>1</sup> VOLTAGE REFERS TO CLUTCH





## Direct Drives

Uniquely, the Direct Drive can operate onto the pedestal or gearbox output lever as an alternative to the rudder lever. This offers the installer and boat designer more options for layout as the Direct Drive can be mounted in any orientation.

- Available in Constellation™, Cobra™ and Mamba™ steering systems
- Extremely powerful, delivering up to 2432Nm/1794ft. lb of torque
- Virtually zero drag – steering performance is not impaired
- Compact Direct Drive, enabling close mounting to the rudder stock, at any attitude



Direct drive connected to a tiller lever via a draglink

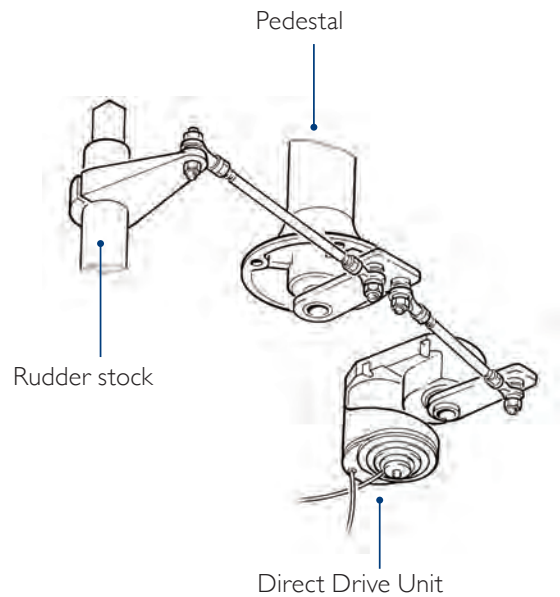

OUTPUT LEVER CENTRE	HP	VOLTAGE <sup>1</sup>	NO LOAD SPEED		MAX RUDDER TORQUE		AVERAGE CURRENT CONSUMPTION	WEIGHT	
			HO-HO		MKG	FT-LB		KG	LB
166MM LEVER	1/4	12	10S		248	1794	4A	8.8	19.4
166MM LEVER	1/4	24	10S		248	1794	4A	8.8	19.4
166MM LEVER	1/2	24	12S		345	2496	3.5A	24.8	55.0
166MM LEVER	1/2	24	17S		493	3566	3.5A	45.5	100.0

<sup>1</sup> VOLTAGE REFERS TO CLUTCH

## 9. Steering



### Rotary Sprocket Drives – To suit Constellation™ & Mamba™

Lewmar offer 3 sizes of powerful and compact rotary drive units, which employ conventional chain and sprocket connection to the steering system.

The high-efficiency, twin-stage, epicyclic gearbox is grease filled, which allows mounting in any attitude. The wide mounting platform is slotted to aid chain tensioning. Rotary drives are generally used on cable and push-pull steering systems and it is necessary to calculate the correct driven sprocket, which is dependent on the turns (mechanical advantage) of the steering system.

Lewmar can supply fully machined sprockets for your steering system in steel or stainless steel upon request, as well as chain and master links.



Please refer to the graph to calculate the correct sprocket size. The turns lock to lock is referred to at the position on the steering where the driven sprocket is to be mounted.

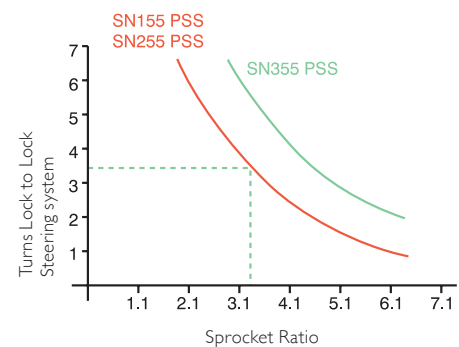

	SPROCKET SIZE	POWER	VOLTAGE <sup>1</sup>	MAX OUTPUT TORQUE		NO LOAD SPEED	MAX RUDDER TORQUE		AVG CURRENT CONSUMPTION	WEIGHT	
		HP		NM	FT. LB	RPM	MKG	FT. LB		KG	LB
89300002	5/8" P 9T SPROCKET	1/4	12	43	32	44	207	1500	4.0A	8.8	19.4
89300004	5/8" P 9T SPROCKET	1/4	24	43	32	44	207	1500	2.5A	8.8	19.4
89300008	5/8" P 9T SPROCKET	1/2	24	47	35	55	332	2400	3.5A	10.0	22.0
89300127	3/4" P 11T SPROCKET	1	24	466	344	18	1660	12055	6.0A	30.0	66.1

<sup>1</sup> VOLTAGE REFERS TO CLUTCH

Lewmar recommends the following drive units for your boat. If your boat is not listed here, please contact your Lewmar representative for further information.

BOAT BUILDER/MODEL	DESCRIPTION	PART NO.
BAVARIA		
30, 33, 39 CRUISERS	INTEGRA	89300136
46 CRUISER, 46 STYLE, VISION 42	INTEGRA	89300180
42, 44, 49, 50 CRUISERS	MAMBA™	89300137
45, C45	DIRECT	89300163
50, C50	DIRECT	89300169
55	DIRECT	89300152
VISION 46	INTEGRA	89300186
DUFOUR		
DUFOUR 34	CONSTELLATION™	89300109
DUFOUR 360, 390, 430, P36	INTEGRA	89300137
DUFOUR 310, 460	INTEGRA	89300170
DUFOUR 40, 44	CONSTELLATION™	89300086
DUFOUR 385, 455	CONSTELLATION™	89300123
GIB SEA 43	MAMBA™	89300137
HALBERG RASSY		
HR 40, 43	MAMBA™	89300137
HR 46, 48, 53 - 12V	MAMBA™	89300137
HR 46, 48, 53 - 24V	MAMBA™	89300054
HR 62	MAMBA™	89300060
HANSE		
588, 575	INTEGRA	89300230
HUNTER		
HUNTER 44, 49	MAMBA™	89300137
HUNTER 45CC	INTEGRA	89300203
ISLAND PACKET		
IP 370	DIRECT	89300040
IP 440	DIRECT	89300040
IP 445	MAMBA™	89300137
IP 485	MAMBA™	89300137

BOAT BUILDER/MODEL	DESCRIPTION	PART NO.
NAJAD		
NAJAD 400	MAMBA™	89300137
NAJAD 460, 490, 511	MAMBA™	89300137
RUSTLER		
RUSTLER 42/44	MAMBA™	89300039
RUSTLER 57	MAMBA™	89300060
GUNFLEET		
GUNFLEET 58	MAMBA™	89300060
GUNFLEET 43	MAMBA™	89300039
VANCOUVER 49	MAMBA™	89300117
OYSTER		
OYSTER 62	MAMBA™	89300060
OYSTER 625	MAMBA™	89300166
OYSTER 655	MAMBA™	89300138
OYSTER 72	MAMBA™	89300070
OYSTER 725	MAMBA™	89300129
OYSTER 82	MAMBA™	89300064
TARTAN		
TARTAN 3400	DIRECT	89300039
TARTAN 3700	DIRECT	89300039
TARTAN 4100	DIRECT	89300039
TARTAN 4400	DIRECT	89300039
DISCOVERY YACHTS GROUP		
DISCOVERY 435	MAMBA™	89300137
DISCOVERY 48	MAMBA™	89300137/89300054
DISCOVERY 54	MAMBA™	89300060
DISCOVERY 55/58	MAMBA™	89300054

# Part Number Index

PART NO	PAGE	PART NO	PAGE	PART NO	PAGE	PART NO	PAGE
56205	91	57816	95	581111	125, 128	589296	107, 128 - 130
56206	91	57820	95	581112	125, 128	589300	122
56207	91	57825	95	581113	125	589301	122
56208	91	57901	93	581114	128	589302	122
56209	91	57902	93	582008	124	589303	122
56210	91	57905	93	582009	124	589310	122
56211	91	57907	93	583041	129	589321	122
57206	89	57910	93	583082	126	589350	121, 122, 126
57210	89	57915	93	583083	126	589351	121 - 123, 126, 129
57216	89	57920	93	583084	126, 129	589352	126
57220	89	57930	93	583085	126, 129	589355	126
57225	89	57950	93	583086	126, 129	589357	121, 126
57232	89	57980	93	583087	126, 129	589358	121, 126
57240	89	58102	85	583088	126, 129	589401	122
57250	89	58103	85	583089	126, 129	589402	122
57263	89	58105	85	583090	126	589403	122
57306	87	58107	85	583091	126	589451	121, 122, 124
57310	87	58110	85	583092	126, 129	589452	124
57316	87	58302	85	583093	126, 129	589453	124
57320	87	58303	85	583094	129	589454	121, 124
57325	87	58305	85	583095	126, 129	589501	122
57332	87	58307	85	583096	126, 129	589502	122
57340	87	58310	85	583097	126, 129	589503	122
57350	87	58901	93	585029	127, 130	589510	122
57363	87	58902	93	585040	126, 127	589550	121, 122
57404	87	58905	93	585041	126, 127, 130	589551	121 - 123, 127, 130
57406	87	58907	93	587032	127	589552	121 - 123, 127, 130
57410	87	58910	93	589006	120, 121, 123	589557	121, 127
57416	87	58915	93	589008	121, 123	589700	122
57420	87	58920	93	589009	121, 123	589701	122
57425	87	58930	93	589010	121, 123	589702	122
57432	87	58950	93	589011	121, 123	589703	122
57440	87	58980	93	589012	121, 123	589710	122
57450	87	551035	125	589013	120, 121, 123	589750	121, 122, 127
57463	87	551052	125	589016	105	589751	121, 122, 127
57506	83	552004	124	589017	105	589752	127
57510	83	552005	124	589018	105	589800	109, 120
57516	83	553034	124, 125, 126	589019	105	589801	109, 120
57520	83	553035	126	589021	105	589802	109, 120
57525	83	553036	126, 127	589064	121, 122	589803	109, 120
57532	83	553071	126	589065	121, 122	589804	109, 120
57540	83	555025	127	589066	121, 122	589805	109, 120
57550	83	555034	126, 127	589094	121	589806	124 - 127
57563	83	555035	127	589096	121, 122	589808	128 - 130
57606	83	555038	127	589101	122	589809	128 - 130
57610	83	557025	127	589102	122	589810	120
57616	83	557030	127	589103	122	589811	120
57620	83	557035	127	589110	122	589813	120
57625	83	559018	121, 122, 125	589150	122, 125, 127	589830	120
57632	83	559033	120	589151	121 - 123, 125, 128	589834	126, 127
57640	83	559036	121	589156	121, 125	589836	125
57650	83	559037	121	589157	128	589844	125, 126
57663	83	559038	121	589206	105	589845	117
57806	95	559107	121, 122, 124	589222	109, 121, 123	589846	117
57808	95	559152	125, 127	589223	109, 121, 123	589856	124, 125
57810	95	559755	127	589267	109, 121, 123	589857	124, 125
57812	95	559775	121	589268	109, 121, 123	589858	126, 127
57814	95	581110	125	589274	107, 124 - 127	589864	120

PART NO	PAGE	PART NO	PAGE	PART NO	PAGE	PART NO	PAGE
589865	120	15000301	268	29141010	252	29196010	302
589866	120	15000464	253, 260	29141011	252	29196011	304
589867	120	15000827	253, 260	29141110	252	29196012	316
590000	106	18000200	52	29141111	252	29196013	316
590001	106	18000237	52	29141122	252	29196014	316
590002	106	18000301	47, 52, 234	29145301	252	29196021	304
590003	106	18000302	47, 52, 234	29145311	252	29196031	303
590004	106	19006100	225	29160112	325	29196034	303
590005	106	19701000	237	29165066	320	29196039	303
590006	106	19701100	237	29166215	344	29196047	302
590007	106	19701500	237	29166225	344	29196061	304
590008	106	19701600	237	29166230	344	29196064	304
590009	106	19810600	314	29170022	310, 312	29196065	297, 304, 315
590010	106	19820600	314	29171010	325	29197201	302
590011	106	19830500	314	29171021	330, 332	29197202	302
590012	106	19899000	178	29171022	312, 310	29197204	302
590013	106	19899100	178	29171024	336	29197211	304
590014	106	19899200	178	29172016	344	29197221	304
590015	106	19899300	178	29172021	330, 332	29197231	303
590016	106	19899400	178	29172024	336	29197234	303
590017	106	19899500	178	29172117	344	29197237	303
590018	106	19899600	178	29175022	312	29197239	303
590019	106	25002323	351	29181315	339	29197247	302
590020	106	25002920	336	29181320	339	29197261	304
590021	106	25003438	336	29181415	338, 339	29197264	304
590022	106	25003969	336	29181420	339	29197265	297, 304, 315
590024	106	27195047	305	29181430	339	29197266	320
590030	106	27196001	305	29182315	339	29199001	302
590031	106	27196002	305	29182320	339	29199004	302
590032	106	27196004	306	29182415	339	29199011	304
590033	106	27196011	305	29182420	338, 339	29199061	304
590034	106	27196021	306	29182430	339	29395000	318
590035	106	27196031	306	29192105	320	29442705	344
590101	106	27196038	306	29194061	294	29471010	336
590102	106	27196039	306	29194062	294	29472010	336
591101	105	27196061	306	29195001	302	29473024	336
591251	105	27197201	305	29195002	302	29900010	312
591482	105	27197202	305	29195003	302	29900011	312
591820	116	27197204	306	29195004	302	29900012	312
591821	116	27197211	305	29195005	302	29900013	312
592510	116	27197221	306	29195009	302	29900014	312
592511	116	27197261	306	29195010	302	29900015	312
592520	116	27197264	306	29195011	304	29900016	312
592521	116	27199001	305	29195021	304	29900017	312
592522	116	29041700	344	29195031	303	29900240	294
593010	116	29042700	344	29195034	303	29900340	294
593011	116	29043702	344	29195037	303	29903401	345
593020	116	29104103	354	29195039	303	29903402	345
593021	116	29104113	354	29195047	302	29903453	345
593022	116	29104115	354	29195061	304	29903454	345
593023	116	29104116	354	29195064	304	29903457	345
4000460	266	29140017	23, 27, 252	29195065	297, 304, 315	29903458	345
6052904	76	29140020	252	29196001	302	29904040	320
6052907	76	29140040	251	29196002	302	29904041	320
6052945	76	29140042	251	29196003	302	29904046	315
6600099	78	29140044	251	29196004	302	29904050	297, 315
6600842	78	29140046	251	29196005	302	29904054	320
15000019	259	29140121	252	29196009	302	29904060	320

PART NO	PAGE	PART NO	PAGE	PART NO	PAGE	PART NO	PAGE
29904104	325	30222000	169	39950030	144	48000077	220
29904105	354	30229100	152	39951030	145	48000078	220
29904115	354	30277800	169	39954012	135	48000116	220
29904117	354	30307400	153	39954020	147	48000117	220
29904118	354	30307500	153	39954030	144	48000178	234
29904126	354	30320600	153	39954812	135	48000179	234
29905410	345	39110070	175	39960012	135	48000180	234
29905412	345	39110090	175	39960020	147	48000181	234
29905414	345	39130070	175	39960030	144	48000211	220
29913316	349	39130090	175	39960812	135	48000212	220
29915076	349	39132070	175	39965030	144	48000217	234
29925040	293, 293, 297, 316	39132090	175	39970012	135	48000220	234
29926040	293, 295, 297, 304, 316	39140070	175	39970020	147	48000221	234
29927240	293, 295, 297, 304, 316	39140090	175	39970812	135	48000222	234
29929040	297, 304, 316	39160070	175	39977020	147, 149	48000224	234
29940487	318	39160090	175	40000901	239	48000225	234
29940707	318	39610050	149	40005066	243	48000227	234
29941207	318	39610070	149	45000023	253, 260	48000229	234
29942106	313	39620050	149	45000037	260	48000256	53, 235
29942136	313	39620070	149	45000118	261	48000257	53, 235
29942156	313	39630050	149	45000120	254, 261	48000258	53, 235
29942606	313	39630070	149	45000218	262	48000259	53, 235
29942806	313	39640050	149	45000222	255, 262	48000446	253 - 268
30067300	145	39640070	149	45000318	263	48000447	260
30069900	152	39644050	149	45000323	256, 263	48000448	261
30074000	152	39644070	149	45000324	256, 263	48000449	262
30179600	169	39650050	149	45000333	256, 263	48000450	263
30183700	169	39650070	149	45000418	264	48000451	264
30183800	169	39654050	149	45000422	257, 264, 265	48000452	265, 266
30184900	169	39654070	149	45000423	257, 264, 265	48000453	267, 268
30187100	169	39660050	149	45000424	257, 264, 265	48000454	253, 260
30190400	139	39660070	149	45000517	265	48000455	254, 261
30190500	139	39670050	149	45000518	265	48000456	255, 262
30190600	139	39670070	149	45000520	258, 266, 267	48000457	256, 263
30192000	169	39900030	144	45000522	258, 266, 267	48000458	257, 264
30192200	169	39903030	144	45000523	258, 266, 267	48000459	265
30193500	139	39910012	135	45000624	258, 259, 266, 268	48000460	258
30193600	176	39910030	144	45000713	268	48000461	267
30195400	139	39910812	135	45000717	267	48000462	259, 268
30196200	169	39918030	145	45000718	267	48000464	255, 262
30196300	169	39920012	135	45000818	268	48000465	254, 261
30196400	169	39920030	144	45000850	268	48000467	255, 262
30198700	169	39920812	135	45000851	259, 268	48000468	256, 257, 263, 264
30203300	169	39922030	145	45500104	254	48000469	256, 263
30204300	178	39930012	135	45500204	255	48000470	257, 264, 265
30204400	176	39930020	147	45500304	256	48000472	258, 266, 267
30205100	178	39930030	144	45500404	257	48000473	258, 265, 266, 267
30206300	169	39930812	135	45500504	258, 266	48000475	259, 268
30206400	169	39940020	147	45500604	259	48000476	259, 268
30206500	169	39940030	144	48000014	237, 253, 260	48000478	260
30206600	169	39941012	135	48000017	237, 258, 259, 265 - 268	48000480	261
30209800	171	39941030	144	48000018	237	48000482	262
30209900	171	39941812	135	48000019	237	48000484	263
30211300	152	39944012	135	48000055	265	48000485	264
30211800	169	39944020	147	48000075	220	48000486	265
30212200	169	39944030	144	48000076	220	48000487	266
30216000	169	39944812	135			48000488	267
30216100	176	39950020	147			48000490	268

PART NO	PAGE	PART NO	PAGE	PART NO	PAGE	PART NO	PAGE
48016017	260	48545017	256	49050015	239	49088104	238
48030017	261	48545200	220	49050050	239	49088109	238
48040040	262	48545201	220	49050101	231	49088245	239
48040300	227	48545210	220	49050103	231	49088248	238
48046017	263	48545300	218	49050125	242	49095001	243
48046300	227	48545301	218	49050130	242	49095004	243
48048040	264	48550017	257	49054000	226	49099000	243
48048300	227	48550200	220	49054001	226	49099009	243
48050300	227	48550201	220	49054050	239	49105002	243
48054300	227	48550210	220	49054100	231	49105006	243
48058300	227	48550300	218	49054101	231	49111104	238
48065300	227	48550301	218	49054103	231	49111109	238
48300027	254, 255, 261, 262	48555017	258	49058000	226	49111255	238
48300029	255, 262	48555200	220	49058001	226	49115000	243
48300036	256, 263	48555201	220	49058050	239	49120001	243
48300043	257, 264, 265	48555210	220	49058100	231	49122104	238
48300060	253, 260	48555300	218	49058101	231	49122121	238
48340200	233	48565017	259	49058103	231	49507075	225
48340201	233	48565200	220	49058104	231	49507076	225
48340210	233	48565201	220	49060000	242	49508075	225
48345200	233	48565210	220	49060009	242	49508076	225
48345201	233	48570200	220	49060015	239	49515055	217
48345210	233	48570201	220	49062050	239	49515056	217
48350200	233	48570206	220	49065000	226	49515057	217
48350201	233	48570207	220	49065001	226	49516075	225
48350210	233	48570208	220	49065100	231	49516076	225
48355200	233	48570210	220	49065101	231	49530055	217
48355201	233	48580200	220	49065103	231	49530056	217
48355210	233	48580201	220	49065104	231	49530057	217
48365200	233	48580206	220	49066000	226	49530075	225
48365201	233	48580207	220	49066001	226	49530076	225
48365210	233	48580208	220	49066005	226	49540055	217
48500005	253	48580210	220	49066006	226	49540056	217
48500015	253	49006075	225	49068001	242	49540057	217
48500016	253	49016000	226	49068021	242	49540075	225
48500030	254	49016001	226	49068100	231	49540076	225
48500031	254, 255	49030000	226	49068101	231	49540085	224
48500040	255	49030001	226	49068103	231	49540087	224
48500045	256	49040050	239	49068104	231	49540217	219
48500046	256	49040055	226	49068105	231	49540218	219
48500050	257	49040056	226	49068106	231	49540219	219
48500051	257	49044014	239	49068108	231	49545055	217
48500055	258	49044050	239	49068109	231	49545056	217
48500056	258	49046055	226	49068160	242	49545057	217
48500060	260	49046056	226	49077000	226	49545085	224
48500065	259	49046155	231	49077001	226	49545087	224
48500066	259, 268	49046156	231	49077005	226	49545100	231
48500105	254, 255	49046158	231	49077006	226	49545217	219
48500305	256	49046159	231	49077035	239	49545218	219
48500405	257, 258	49048015	239	49077100	231	49545219	219
48500605	259	49048050	239	49077101	231	49550055	217
48530017	254	49048055	226	49077103	231	49550056	217
48540017	255	49048056	226	49077104	231	49550057	217
48540200	220	49048156	231	49077105	231	49550100	231
48540201	220	49048158	231	49077106	231	49550101	231
48540210	220	49048159	231	49077108	231	49550110	231
48540300	218	49050000	226	49077109	231	49550217	219
48540301	218	49050001	226	49082000	243	49550218	219

PART NO	PAGE	PART NO	PAGE	PART NO	PAGE	PART NO	PAGE
49550219	219	56110003	123, 130	59093011	114	65001688	35
49555055	217	56110004	123, 128	59093012	114	65003097	99
49555056	217	56110005	123, 129	59093013	114	66000002	77
49555057	217	56110006	123, 130	59093014	114	66000003	77
49555100	231	56110007	123, 128	59093015	114	66000004	77
49555101	231	56110008	123, 129	59093020	113	66000005	77
49555200	219	56110009	123, 130	59093021	113	66000006	45, 77
49555201	219	56110010	123, 128	59093022	113	66000007	45, 77
49555210	219	56110011	123, 129	59093023	113	66000008	77
49555220	219	56110012	123, 130	59093024	113	66000009	77
49555221	219	56110013	128, 129, 130	59093025	113	66000010	77
49555230	219	56110014	128, 129	59093026	113	66000011	77
49565055	217	56110015	129	59093027	113	66000012	77
49565056	217	56110016	130	59094001	113	66000013	77
49565057	217	56110017	130	59094002	114	66000014	77
49565101	231	56110018	130	59094003	113	66000015	77
49565200	219	56110019	123, 128, 129	59094004	114	66000016	77
49565201	219	56110020	123, 130	59111001	111	66000017	77
49565210	219	56110021	128, 129, 130	59111002	111	66000018	77
49565220	219	56110022	128, 129	59111003	111	66000019	77
49565221	219	56110023	129	59111004	111	66000020	77
49565230	219	56110024	130	59112004	111	66000021	77
49570055	218	56110025	130	59112005	111	66000022	77
49570056	218	56110026	122, 123, 128	59112006	111	66000023	77
49570057	218	56110027	122, 123, 129	59112007	111	66000024	77
49570065	218	56110028	122, 123, 130	59112008	111	66000025	77
49570066	218	56110029	128, 129	59112009	111	66000027	77
49570067	218	56110030	129	59112010	111	66000028	77
49570211	219	56110031	130	59112011	111	66000029	77
49570212	219	56110032	122, 123, 128	59112012	111	66000030	77
49570213	219	56110033	122, 123	59112013	111	66000060	70, 71
49570220	219	56110034	122, 123, 130	59112014	111	66000065	71, 72
49570221	219	58090000	115	59112019	111	66000070	72
49570230	219	58090001	115	59112020	111	66000071	72
49580065	218	58090002	115	59112021	111	66000072	72
49580066	218	58090003	115	59112022	111	66000073	72
49580067	218	58090009	113	59112023	111	66000075	72
49580101	231	58090010	113	59112024	111	66000076	72
49580102	231	58090011	113	59112025	111	66000077	72
49580211	219	58090012	113	59112026	111	66000079	72
49580212	219	58090013	113	59112027	111	66000096	75
49580213	219	58090019	113	59113001	111	66000098	75, 76
49580220	219	58090023	120	59113002	111	66000099	69, 75, 76
49580221	219	59092000	113	59113005	111	66000101	75
49580230	219	59092001	113	59113006	111	66000102	75
49730055	222	59092002	114	59127002	118	66000600	65, 69
49740055	222	59092003	113	59127004	118	66000601	65, 69
49745055	222	59092004	113	59127100	118	66000602	69
49750055	222	59092005	114	59127110	118	66000605	69
49755055	222	59093000	113	59137001	118	66000606	69
49940055	223	59093001	113	59137002	118	66000607	69
49945055	223	59093002	113	59137003	118	66000608	69
49950055	223	59093003	113	59137004	118	66000609	69
49955055	223	59093004	113	59600140	248	66000610	69
51000370	119	59093005	113	59600142	248	66000611	69
51000470	119	59093006	113	59600150	248	66000612	69
56110001	123, 128	59093007	113	59600152	248	66000613	69
56110002	123, 129	59093010	114	65001687	35	66000614	69



PART NO	PAGE	PART NO	PAGE	PART NO	PAGE	PART NO	PAGE
66000615	69	66000750	68	66100130	62	66830028	60
66000616	43, 75	66000751	68	66100135	62	66830029	60
66000617	75	66000752	68	66100136	62	66830030	60
66000620	75	66000754	68	66100137	62	66830031	60
66000624	70, 71	66000755	68	66100138	62	66830032	60
66000625	70, 71	66000758	75	66100139	62, 74	66830035	60
66000626	70, 71	66000759	75	66100140	62	66830040	59
66000627	70	66000760	75	66100141	62, 74	66830041	59
66000628	70, 71	66000761	75	66100142	62, 74	66840003	30, 68
66000629	70	66000762	75	66100143	11, 15, 64	66840005	30, 68
66000631	70, 71	66000763	75	66120001	63, 64	66840007	100
66000632	70, 71	66000764	75	66120002	63	66840008	100
66000633	70, 71	66000766	43, 75	66120003	63	66840009	100
66000634	75	66000768	43, 75	66120004	63	66840027	98
66000639	60	66000769	75, 76	66120005	63	66840028	98
66000640	71	66000770	65	66120006	63, 64	66840045	45, 77
66000641	71	66000771	65	66120007	63	66840054	23, 27, 70, 71
66000642	71	66000772	65	66120008	63	66840056	23, 27, 67, 71
66000643	76	66000773	65	66120009	63, 64	66840060	100
66000644	76	66000774	65	66120010	15, 63	66840077	99
66000645	76	66000775	37	66120011	63, 64	66840078	99
66000646	76	66000791	66, 67	66120012	64	66840079	99
66000647	76	66000792	66, 67	66120013	64	66840080	99
66000648	76	66000793	66	66120014	64	66840081	99
66000649	76	66000794	68	66140001	74	66840082	99
66000650	76	66000795	68	66140002	74	66840083	99
66000651	76	66000796	68	66140003	74	66840084	66, 67
66000674	73	66000799	61, 62, 63, 64	66140004	74	66840085	100
66000675	73	66000805	65	66140005	74	66840096	100
66000676	73	66000810	78	66140006	74	66840329	99
66000677	73	66000811	78	66140007	74	66910422	20
66000678	73	66000816	78	66140008	41, 74	66910423	20
66000679	73	66000817	78	66140009	74	66910424	20
66000680	73	66000819	15	66140010	74	66910425	20
66000681	73	66000832	78	66140011	74	66910426	20
66000682	73	66000833	78	66140012	74	66910427	20
66000683	73	66000834	78	66200076	70, 71, 72	66910428	20
66000684	73	66000835	78	66810007	27, 71	66910429	20
66000685	73	66000836	78	66810008	27, 71	66910437	20
66000686	73	66000837	78	66810011	30, 47	66910438	20
66000687	73	66000838	78	66810012	30, 47	66910439	20
66000688	73	66000839	78	66810024	30	66910440	20
66000691	35	66000840	78	66810025	30	66910441	48
66000692	32, 73	66000841	78	66810030	27, 66, 67, 70, 71	66910553	50
66000713	67	66000843	78	66810031	30, 68, 72	66940002	56
66000720	66, 67	66000844	78	66810032	47	68000024	32, 35
66000721	37	66000845	78	66810065	27, 70	68000037	32
66000722	37	66001190	78	66810132	27	68000129	52
66000723	37	66100120	61, 62	66830011	60	68000130	52
66000724	37	66100121	61	66830014	57	68000239	234
66000725	37	66100122	62	66830015	59	68000240	52, 234
66000738	37	66100123	61, 62	66830016	60	68000294	30, 47
66000741	66, 67	66100124	61, 62, 74	66830021	60	68000318	52
66000743	66	66100125	61	66830022	60	68000319	52
66000744	67, 68	66100126	61	66830023	60	68000320	52
66000745	67	66100127	61	66830025	60	68000321	52
66000746	67	66100128	62	66830026	60	68000348	52, 234
66000747	67	66100129	62	66830027	60	68000349	52, 234

PART NO	PAGE	PART NO	PAGE	PART NO	PAGE	PART NO	PAGE
68000350	47, 52, 234	68000939	52	68001078	23	69000408	32
68000351	47, 52, 234	68000943	37	68001123	65	69000409	32
68000356	30	68000944	37	68001125	65	69000411	47
68000357	30	68000945	37	68001126	65	69000412	98
68000358	30	68000946	37	68001165	39	69000414	47
68000359	30	68000951	27	68001249	53, 235	69000415	47
68000360	27, 70, 71	68000967	54	68001256	53, 235	68000416	34
68000361	27, 70, 71	68000968	54	68001257	53, 235	69000418	37
68000362	27, 70, 71	68000969	55	68001258	53, 235	69000419	37
68000363	27, 71	68000973	34, 37	68010878	68	69000421	37
68000527	27, 71	68000974	34, 37	68100033	9, 61, 62	69000422	37
68000534	30, 47	68000975	34, 37	68100034	9, 61, 62	69000423	37
68000535	30, 47	68000976	47	68100035	61	69000424	37
68000538	27, 71	68000977	47	68100036	61	69000427	37
68000542	234	68000978	47	68120031	63, 64	69000428	37
68000593	55	68000979	47	68120032	63, 64	69000444	34
68000603	52	68000980	47	68120033	63, 64	69000445	34
68000604	52	68000981	34, 37	68120034	63, 64	69000447	37
68000813	27, 71	68000982	34, 37	68120035	63, 64	69000448	37
68000814	27, 71	68000983	34, 37	68120036	63, 64	69000449	37
68000815	27, 71	68000984	47	68120040	9, 63, 64	69000450	37
68000816	27, 71	68000985	47	68120041	9, 63, 64	69000453	47
68000828	27	68000986	47	68120042	9, 63, 64	69000456	47
68000829	27	68000987	47	68120043	9, 63, 64	69000458	47
68000840	27, 70	68000988	47	68140009	9, 74	69000460	37
68000866	23, 27, 30	68001005	55	68140010	9	69000461	37
68000867	30	68001006	55	69000331	100	69000462	37
68000876	35	68001023	35	69000332	100	69000463	37
68000877	34	68001024	69	69000334	100	69000464	37
68000878	34	68001035	65	69000335	100	69000465	37
68000879	34	68001042	66	69000339	100	69000466	37
68000880	34	68001043	67	69000377	34	69000467	37
68000881	34	68001044	67	69000378	34	69000468	37
68000883	53	68001045	67	69000379	34	69000469	37
68000884	53	68001046	67	69000380	34	69000471	37
68000888	53	68001047	23, 66, 67	69000381	34	69000480	23
68000889	53	68001048	23, 66, 67	69000382	34	69000481	27
68000894	52, 234	68001049	23, 66, 67	69000383	34	69000483	23
68000895	52	68001050	23, 66, 67	69000384	34	69000484	27
68000897	35	68001051	23, 66, 67	69000385	34	69000485	27
68000900	34	68001052	27	69000386	34	69000491	47
68000901	47	68001053	27	69000387	34	69000493	23
68000903	32	68001054	27	69000388	34	69000494	23
68000904	32	68001055	27	69000390	34	69000495	23
68000905	32	68001063	23, 68	69000391	34	69000496	47
68000906	32	68001064	23, 68	69000392	34	69000499	98
68000917	53	68001065	23, 68	69000393	34	69000507	98
68000918	53	68001066	23, 68	69000394	34	69000508	98
68000919	47, 52	68001068	23	69000395	34	69000515	98
68000920	47, 52	68001069	23	69000396	34	69000544	97
68000928	53	68001070	23	69000397	34	69000545	97
68000929	53	68001071	23	69000400	32	69000546	97
68000930	53	68001072	23	69000401	32	69000547	97
68000932	37	68001073	23, 67	69000402	32	69000548	97
68000933	47, 52, 234	68001074	23, 67	69000403	32	69000549	97
68000934	47, 52, 234	68001075	23, 67	69000404	32	69000550	97
68000937	52	68001076	23, 67	69000405	32	69000551	97
68000938	52	68001077	23, 68	69000407	32	69000552	97

PART NO	PAGE	PART NO	PAGE	PART NO	PAGE	PART NO	PAGE
69000553	97	69100068	19	69120090	15	69120158	17
69000560	97	69100069	19	69120091	15	69120159	17
69000561	97	69120020	15	69120092	15	69120160	17
69000585	97	69120021	15	69120093	15	69120161	17
69000586	97	69120022	15	69120094	15	69120162	17
69000608	99	69120023	15	69120095	15	69120163	17
69000609	99	69120024	15	69120096	15	69120190	17
69000610	99	69120025	15	69120097	15	69120191	17
69000641	39	69120026	15	69120100	15	69120192	17
69000642	39	69120027	15	69120101	15	69120193	17
69000643	39	69120030	15	69120102	15	69120194	17
69000644	39	69120031	15	69120103	15	69120195	17
69000645	39	69120032	15	69120104	15	69120196	17
69000646	39	69120033	15	69120105	15	69120197	17
69000807	50	69120034	15	69120106	15	69120198	17
69000819	55	69120035	15	69120107	15	69120199	17
69000940	49	69120036	15	69120110	15	69120200	17
69000941	49	69120037	15	69120111	15	69120201	17
69000942	49	69120040	15	69120112	15	69120202	17
69000943	49	69120041	15	69120113	15	69120203	17
69000944	49	69120042	15	69120114	15	69120204	17
69000945	49	69120043	15	69120115	15	69120205	17
69001015	51	69120044	15	69120116	15	69120206	17
69001016	51	69120045	15	69120117	15	69120207	17
69001017	51	69120046	15	69120120	15	69120208	17
69001018	51	69120047	15	69120121	15	69120209	17
69100020	11	69120050	15	69120122	15	69120210	17
69100021	11	69120051	15	69120123	15	69120211	17
69100022	11	69120052	15	69120124	15	69120212	17
69100023	11	69120053	15	69120125	15	69120213	17
69100024	11	69120054	15	69120126	15	69140001	41
69100025	11	69120055	15	69120127	15	69140002	41
69100026	11	69120056	15	69120130	15	69140003	41
69100027	11	69120057	15	69120131	15	69140004	41
69100030	11	69120060	15	69120132	15	69140005	41
69100031	11	69120061	15	69120133	15	69140006	41
69100032	11	69120062	15	69120134	15	69140007	41
69100033	11	69120063	15	69120135	15	69140008	41
69100034	11	69120064	15	69120136	15	69140009	41
69100035	11	69120065	15	69120137	15	69140010	41
69100036	11	69120066	15	69120140	17	69140011	41
69100037	11	69120067	15	69120141	17	69140012	41
69100050	13	69120070	15	69120142	17	69140030	41
69100051	13	69120071	15	69120143	17	69140031	41
69100052	13	69120072	15	69120144	17	69140032	41
69100053	13	69120073	15	69120145	17	69140033	41
69100054	13	69120074	15	69120146	17	69140034	41
69100055	13	69120075	15	69120147	17	69140035	41
69100056	13	69120076	15	69120148	17	69140036	41
69100057	13	69120077	15	69120149	17	69140037	41
69100060	13	69120080	15	69120150	17	69140038	41
69100061	13	69120081	15	69120151	17	69140039	41
69100062	13	69120082	15	69120152	17	69140040	41
69100063	13	69120083	15	69120153	17	69140041	41
69100064	13	69120084	15	69120154	17	69600533	45
69100065	13	69120085	15	69120155	17	69600534	45
69100066	13	69120086	15	69120156	17	69600537	45
69100067	13	69120087	15	69120157	17	69600538	45

PART NO	PAGE	PART NO	PAGE	PART NO	PAGE	PART NO	PAGE
69600541	45	89400035	386	89700265	377	291213305	340
69600542	45	89400046	386	89700266	377	291213308	340
69600544	45	89400047	386	89700267	377	291213315	338, 341
69600545	45	89400084	386	89700268	377	291213406	341
69600546	45	89400100	388	89700297	377	291213408	340
69600548	45	89400109	386, 390	89700298	377	291213412	341
82000356	369	89400120	386	89700299	377	291213501	341
82000357	369	89400133	390	89700300	377	291213537	341
89100078	361	89400136	390	89700301	377	291214305	342
89100090	361	89400137	390	89700375	377	291214308	342
89100091	361	89400146	390	89700376	377	291214537	342
89100092	361	89400283	389	89700377	377	291214815	343
89100093	361	89400284	389	89700406	377	291215305	342
89100094	361	89400285	389	89700407	377	291215308	342
89100095	361	89400286	389	89700408	377	291215537	342
89100096	361	89400316	390	89700520	377	291215815	343
89100100	361	89400365	389	89700521	377	291218805	342
89100102	362	89400420	389	89700593	377	291218806	338, 342
89100143	379	89400423	387	89700821	382	291218808	343
89100144	379	89400425	387	89700822	382	291218809	343
89100149	362	89400427	387	89700823	382	291218817	343
89101097	362	89400429	387	89700824	382	291218818	342
89101098	362	89400430	387	89700825	382	291218837	342
89101144	362	89400432	388	89700827	382	291219901	343
89101145	362	89400434	388	89700828	382	291219905	343
89101173	362	89400435	389	89700830	382	291219907	343
89101174	362	89400437	389	89700831	382	291219910	343
89300002	394	89400439	389	89700862	381	291219911	343
89300004	394	89400440	388	89700864	382	291222301	340
89300008	394	89400441	388	89700865	382	291222301	340
89300039	395	89400442	388	89700871	382	291223305	340
89300040	395	89400470	382	89700909	382	291223306	340
89300054	395	89400471	382	89700910	382	291223308	340
89300060	395	89400472	382	89700911	382	291223315	341
89300064	395	89400473	382	89700913	382	291223406	341
89300070	395	89400475	382	89700914	382	291223408	340
89300086	395	89400476	382	89700915	382	291223412	341
89300109	395	89400479	382	89700917	382	291223415	338, 341
89300117	395	89500002	369	89700918	382	291223501	341
89300123	395	89500005	369	89700919	382	291223537	341
89300127	394	89500008	369	89700921	382	291223601	341
89300129	395	89500011	369	89700922	382	291223606	341
89300136	392, 395	89500012	369	89700923	382	291224305	342
89300137	395	89500013	369	89700924	382	291224308	342
89300138	395	89500014	369	89700926	382	291224537	342
89300152	395	89700024	377	89800013	390	291224815	343
89300163	395	89700025	377	89800053	379	291225305	342
89300166	395	89700063	377	89800123	379	291225308	342
89300169	395	89700092	377	89900003	383	291225537	342
89300170	395	89700093	377	89900014	384	291225815	343
89300180	395	89700094	377	89900031	383	291228805	342
89300186	395	89700095	377	89900034	384	291228806	338, 342
89300203	392, 395	89700096	377	89900046	383	291228808	343
89300230	395	89700097	377	89900052	384	291228809	343
89400000	390	89700098	377	89900299	385	291228817	343
89400001	390	89700161	379	89900302	385	291228818	342
89400031	386	89700162	379	89900306	385	291228837	342
89400033	386	89700264	377	291213301	340	291229901	343

PART NO	PAGE	PART NO	PAGE	PART NO	PAGE	PART NO	PAGE
291229905	343	360867999	163	361196992	161	367654252	161
291229907	343	360868999	163	361206999	162	367660252	161
291229910	343	360869999	163	361207999	162	367665252	161
291229911	343	360870999	163	361263999	162	367670252	161
360060990	162	360871999	163	361446999	163	367700300	186
360255990	162	360872999	163	361590999	163	367710100	181
360255992	162	360873999	163	361591999	163	367710150	187
360256990	162	360874999	163	361592999	163	367710200	185
360256992	162	360875999	163	361594999	163	367710300	186
360259990	161	360876999	163	361595999	163	367710400	183
360271990	162	360917990	162	361596999	163	367720100	181
360272990	162	360918299	163	361597999	163	367720150	187
360273990	162	360918992	161	361598999	163	367720200	185
360360999	174	360918999	161	361680990	162	367720400	183
360361999	174	360919990	162	361680992	162	367730100	181
360362999	174	360919992	162	361724029	178	367730150	187
360363999	174	360924990	162	361724829	178	367730200	185
360370999	163	360924992	162	361725029	178	367730300	186
360371999	163	360925999	162	361725829	178	367730400	183
360372999	163	360926999	162	361726029	178	367740100	181
360373999	163	360959999	163	361726829	178	367740150	187
360374999	163	360960999	163	361727029	178	367740200	185
360375999	163	360961999	163	361727829	178	367740300	186
360376999	163	360962999	163	361728029	178	367740400	183
360377999	163	360963999	163	361799999	168	367741100	181
360378999	163	360964999	163	361800999	168	367744100	181
360379999	163	360965999	163	361894999	163	367744150	187
360380999	163	360966999	163	361899990	161	367744200	185
360381999	163	360968999	163	361899991	161	367744400	183
360382999	163	361009009	178	367110936	178	367745300	186
360383999	163	361010999	178	367130936	178	367750100	181
360532009	178	361027999	162	367132936	178	367750150	187
360533009	178	361041990	161	367140936	178	367750200	185
360534009	178	361041992	161	367160936	178	367750400	183
360684009	178	361044999	162	367302936	178	367754100	181
360686009	178	361050900	163	367312936	178	367754150	187
360750009	178	361051900	163	367318936	178	367754200	185
360751009	178	361052900	163	367318966	178	367754400	183
360752009	178	361053900	163	367322936	178	367760100	181
360753009	178	361054900	163	367332936	178	367760150	187
360754009	178	361055900	163	367342936	178	367760200	185
360755009	178	361056900	163	367352936	178	367760400	183
360756009	178	361057900	163	367378936	178	367770100	181
360757009	178	361058900	163	367378966	178	367770150	187
360758999	178	361059900	163	367382966	178	367770200	185
360759999	178	361060900	163	367400252	161	367770400	183
360760999	178	361062900	163	367403252	161	367780100	181
360761999	178	361063900	163	367410252	161	393010262	171
360762999	178	361064900	163	367420252	161	393020200	173
360763999	178	361065900	163	367441252	161	393020262	171
360765999	178	361130900	163	367618252	161	393029800	169
360860999	163	361131900	163	367620252	161	393029802	169
360861999	163	361132900	163	367622252	161	393110262	171
360862999	163	361133900	163	367630252	161	393120200	173
360863999	163	361134900	163	367640252	161	393120262	171
360864999	163	361135900	163	367644252	161	393129800	169
360865999	163	361136900	163	367650252	161	393129802	169
360866999	163	361137900	163	367651252	161	393170262	171

PART NO	PAGE	PART NO	PAGE	PART NO	PAGE	PART NO	PAGE
393180200	173	6672012001	22	29101312BK	351	29171046BK	336
393180262	171	6672012002	22	29101410BK	351	29172040BK	335
393220200	173	6672021000	22	29101412BK	351	29172046BK	336
393320200	173	6672021001	22	29101414BK	351	29173040BK	335
393329800	169	6672021002	22	29101501BK	351	29173046BK	336
393420200	173	6672021003	22	29102410BK	351	29330105BK	324
393429800	169	6672021006	22	29102412BK	351	29330107BK	324
393440200	173	6672022001	22	29102414BK	351	29331153BK	319
393460200	173	6672022002	22	29103410BK	351	29332259BK	319
393520200	173	6672211000	22	29103412BK	351	293712320BK	349
393529800	169	6672211001	22	29103414BK	351	293712321BK	349
393770262	171	6672211002	22			293712322BK	349
393780200	173	6672211003	22	29104100BK	293, 297, 303, 325, 354, 295, 297, 303, 354	293712330BK	349
393780262	171	6672212001	22			293712331BK	349
393810862	171	6672212002	22	29104104BK	354	293712332BK	349
393820862	171	6672212003	22	29104114BK	354	293712340BK	349
399100303	144	6672221000	22	29139112BK	353	293712341BK	349
399104924	137	6672221001	22	29139113BK	353	293712342BK	349
399104996	137	6672221002	22	29139114BK	353	29421300BK	328
399204924	137	6672221003	22	29139115BK	353	29421366BK	331
399204996	137	6672222001	22	29139116BK	353	29421400BK	328
399300303	144	6672222002	22	29139122BK	353	29422300BK	328
399304923	137	6672222003	22	29139123BK	353	29422400BK	328
399304995	137	68001166	39	29139124BK	353	29423301BK	328
399400303	144	68001167	39	29139125BK	353	29423400BK	328
399414924	137	68001168	39	29139126BK	353	29431300BK	328
399414996	137	0056503W	91	29160315BK	323	29431311BK	329
399440303	144	0056504W	91	29160405BK	323	29431312BK	329
399441910	138	0056505W	91	29160410BK	323	29431315BK	329
399441999	138	0056506W	91	29160415BK	323	29431316BK	330
399444923	137	0056507W	91	29161115BK	327	29431337BK	330
399444995	137	0056508W	91	29161415BK	323	29431400BK	328
399500303	144	0056509W	91	29161420BK	323	29431411BK	329
399540303	144	0056510W	91	29161430BK	323	29431412BK	329
399544923	137	0056511W	91	29161510BK	323	29431415BK	329
399544995	137	0056513W	91	29161515BK	323	29431416BK	330
399600303	144	0056515W	91	29161520BK	323	29431500BK	332
399601910	138	0056530W	91	29162115BK	323	29431712BK	329
399601999	138	0056540W	91	29162118BK	327	29431814BK	330
399604923	137	0056550W	91	29162120BK	323	29431834BK	330
399604995	137	0056560W	91	29162130BK	323	29431916BK	327, 331
399701910	138	28003225BK	336	29162315BK	323	29432300BK	328
399701999	138	28003226BK	336	29162320BK	323	29432311BK	329
399704923	137	29020701BK	324	29162415BK	323	29432312BK	329
399704995	137	29030100BK	324, 325	29162420BK	323	29432315BK	329
668400691	99	29030600BK	324	29162430BK	323	29432316BK	330
897000925	382	29040100BK	325	29162515BK	323	29432372BK	329
6630331312	47	29040600BK	325	29162520BK	323	29432400BK	328
6630332312	47	29060152BK	325	29163315BK	323	29432411BK	329
6670011108	24	29100010BK	351	29163320BK	323	29432412BK	329
6671011000	22	29101108BK	351	29163330BK	323	29432415BK	329
6671011001	22	29101110BK	351	29163615BK	323	29432416BK	330
6671011006	22	29101112BK	351	29163620BK	323	29432420BK*	328
6672011000	22	29101208BK	351	29163630BK	323	29432424BK	329
6672011001	22	29101210BK	351	29170030BK	325	29432500BK	332
6672011002	22	29101212BK	351	29170033BK	325	29432511BK	333
6672011003	22	29101308BK	351	29170040BK	325	29432512BK	333
6672011006	22	29101310BK	351	29171040BK	335	29432814BK	330

PART NO	PAGE	PART NO	PAGE	PART NO	PAGE	PART NO	PAGE
29432816BK	331	29471042BK	336	29901426BK	293	29903452BK	345
29432822BK	331	29471063BK	335	29901428BK	293	29905105BK	334
29432823BK	331	29471836BK	335	29901429BK	293	29905200BK	334
29432832BK	331	29472011BK	336	29901430BK	294	29905400BK	345
29432833BK	331	29472012BK	336	29901441BK	293	29905401BK	345
29432836BK	330	29472015BK	336	29901447BK	294	29906171BK	310
29432838BK	331	29472018BK	336	29901460BK	294	29906172BK	310
29433300BK	328	29472030BK	334	29901463BK	294	29906601BK	310
29433314BK	329	29472031BK	334	29901600BK	307	29906602BK	310
29433400BK	328	29472035BK	334	29901611BK	307	29906621BK	310
29433414BK	329	29472036BK	335	29901612BK	308	29906622BK	310
29433416BK	330	29472037BK	335	29901614BK	307	29906801BK	310
29433602BK	329	29472038BK	334	29901615BK	308	29906802BK	310
29433604BK	329	29472041BK	336	29901624BK	309	29906821BK	310
29433832BK	331	29472042BK	336	29901631BK	309	29906822BK	310
29433833BK	331	29472062BK	335	29901634BK	309	29913101BK	349
29441301BK	331	29472063BK	335	29901639BK	309	29913111BK	349
29441311BK	332	29472076BK	335	29901647BK	312	29913313BK	349
29441312BK	332	29472501BK	334	29901661BK	295	29915075BK	349
29441321BK	332	29472535BK	334	29901665BK	295	29916042BK	353
29441322BK	332	29472616BK	335	29901667BK	295	29916060BK	353
29441331BK	332	29472836BK	335	29901668BK	295	29917420BK	345
29441332BK	332	29473030BK	334	29901670BK	295	29917430BK	345
29441345BK	332	29473032BK	335	29901807BK	312	29917440BK	345
29441500BK	333	29473035BK	334	29901811BK	307	29917450BK	345
29441513BK	333	29473036BK	335	29901812BK	308	29925001BK	298
29441701BK	335	29473037BK	335	29901813BK	308	29925002BK	298
29441723BK	332	29473037CBK	335	29901814BK	307	29925003BK	298
29442301BK	331	29473041BK	336	29901815BK	308	29925004BK	298
29442311BK	332	29473063BK	335	29901816BK	309	29925005BK	298
29442312BK	332	29473135BK	334	29901821BK	308	29925009BK	298
29442321BK	332	29473136BK	335	29901822BK	309	29925010BK	298
29442322BK	332	29901107BK	312	29901824BK	309	29925021BK	299
29442331BK	332	29901301BK	293	29901825BK	308	29925031BK	298
29442332BK	332	29901314BK	293	29901828BK	308	29925034BK	299
29442345BK	332	29901320BK	292	29901829BK	308	29925037BK	299
29442412BK	333	29901321BK	292	29901830BK	309	29925039BK	299
29442500BK	333	29901322BK	292	29901831BK	309	29926001BK	298
29442701BK	335	29901323BK	292	29901834BK	309	29926002BK	298
29442723BK	332	29901324BK	292	29901839BK	309	29926003BK	298
29443311BK	332	29901325BK	292	29902100BK	313	29926004BK	298
29443611BK	332	29901326BK	293	29902101BK	313	29926005BK	298
29443700BK	333	29901328BK	293	29902108BK	314	29926010BK	298
29443700CBK	333	29901330BK	294	29902109BK	314	29926021BK	299
29443701BK	335	29901341BK	293	29902131BK	313	29926031BK	298
29443702BK	333	29901360BK	294	29902138BK	314	29926034BK	299
29461354BK	327, 338	29901361BK	294	29902139BK	314	29926037BK	299
29471011BK	336	29901362BK	294	29902151BK	313	29926039BK	299
29471012BK	336	29901363BK*	294	29902158BK	314	29926061BK	300
29471015BK	336	29901365BK	294	29902159BK	314	29926064BK	300
29471018BK	336	29901401BK	293	29902178BK	314	29927201BK	298
29471030BK	334	29901411BK	294	29902179BK	314	29927202BK	298
29471031BK	334	29901420BK	292	29902208BK	314	29927203BK	298
29471032BK	327, 335	29901421BK	292	29902209BK	314	29927204BK	298
29471035BK	334	29901422BK	292	29902800BK	313	29927205BK	298
29471036BK	335	29901423BK	292	29902808BK	314	29927210BK	298
29471037BK	335	29901424BK	292	29902809BK	314	29927221BK	299
29471041BK	336	29901425BK	292	29903451BK	345	29927231BK	298

PART NO	PAGE	PART NO	PAGE	PART NO	PAGE
29927234BK	299	6656411198-311	43	B15279	121
29927237BK	299	6656411199-311	43	B15282	121
29927239BK	299	6656811967-303	44	B15283	121
29927261BK	300	6657011108-102	43	B15284	121
29927264BK	300	6657011198-311	43	B17198	121
29929001BK	298	6657011967-311	43	B8429	127
29929002BK	298	6670011108-312	24	HM10HT200PX	100
29929003BK	298	6671011107-138	26	HM15H300PX	100
29929004BK	298	6671011196-138	26	HM15HT300PX	100
29929021BK	299	6671011197-138	26	R19-050	361
29929031BK	298	6671011198-138	26	SWIVEL312F*	99
29929034BK	299	6672011108-138	26	SWIVEL500F*	99
29929039BK	299	6672011110-138	26	SWIVEL6*	99
29929061BK	300	6672011196-138	26		
29929064BK	300	6672011197-138	26		
29941100BK	311	6672011198-138	26		
29941101BK	311	6672012108-140	26		
29941104BK	311	6672012198-140	26		
29941130BK	311	6672021108-138	26		
29941131BK	311	6672021110-138	26		
29941134BK	311	6672021196-138	26		
29941150BK	311	6672021197-138	26		
29941151BK	311	6672021198-138	26		
29941154BK	311	6672022108-140	26		
29941408IF	319	6672022198-140	26		
29941600BK	311	6672211108-139	26		
29941611BK	311	6672211110-139	26		
29941612BK	312	6672211197-139	26		
29941613BK	312	6672211198-139	26		
29941614BK	311	6672212108-142	26		
29941615BK	312	6672212110-142	26		
29941800BK	307, 311	6672212198-142	26		
29941801BK	311	6672221108-139	26		
29941802BK	312	6672221110-139	26		
29941804BK	311	6672221197-139	26		
29941805BK	312	6672221198-139	26		
29941808BK	312	6672222108-142	26		
29941831BK	312	6672222110-142	26		
29941834BK	312	6672222198-142	26		
29942010IF	319	69000383M	34		
29942601BK	309, 313	69000384M	34		
29943012IF	319	69000444M	34		
29946101BK	313	69000445M	34		
29946102BK	313	69000500	98		
29946131BK	313	69000504	98		
29946132BK	313	69000506	98		
29946151BK	313	69000509	98		
29946152BK	313	69000510	98		
29946611BK	313	89400002	390		
29946612BK	313	B11126	125, 126		
29946801BK	313	B11127	126		
29946802BK	313	B11128	126		
36168099*	162	B11129	126, 127		
529-075	76	B11130	126		
559017A	121, 122, 126	B11762	127		
589007	121, 123	B12373	121		
6656011967-310	43	B12526	124, 125		
6656211967-310	43	B13336	121		



**NOTES:**

**NOTES:**

## Limited Warranty and Key Terms of supply by Lewmar

Lewmar warrants that in normal private pleasure boat usage and with proper maintenance its products will conform with their specification for a period of three years from the date of purchase by the end user, subject to the conditions, limitations and exceptions listed below. Any product, which proves to be defective in normal usage during that three-year period, will be repaired or, at Lewmar's option, replaced by Lewmar.

### A CONDITIONS AND LIMITATIONS

- i** Lewmar's liability shall be limited to the repair or replacement of any parts of the product which are defective in materials or workmanship.
- ii** Responsibility for the selection of products appropriate for the use intended by the Buyer shall rest solely with the Buyer and Lewmar accepts no responsibility for any such selection.
- iii** Lewmar shall not be liable in any way for Product failure, or any resulting loss or damage which arises from:
  - a.** use of a product in an application for which it was not designed or intended;
  - b.** corrosion, ultra violet degradation or wear and tear;
  - c.** a failure to service or maintain the product in accordance with Lewmar's recommendations;
  - d.** Faulty or deficient installation of the product (unless conducted by Lewmar);
  - e.** any modification or alteration of the product;
  - f.** conditions that exceed the product's performance specifications or Working Load Limits.
- iv** Product subject to a warranty claim must be returned to the Lewmar outlet which supplied the product for examination unless otherwise agreed by Lewmar in writing.
- v** This warranty does not cover any incidental costs incurred for the investigation, removal, carriage, transport or installation of product.
- vi** Service by anyone other than authorised Lewmar representatives shall void this warranty unless it accords with Lewmar guidelines and standards of workmanship.
- vii** Lewmar's products are intended for use only in the marine environment. Buyers intending to use them for any other purpose should seek independent professional advice as to their suitability. Lewmar accepts

no liability arising from such other use.

### B EXCEPTIONS

Cover under this Warranty is limited to a period of one year from the date of purchase by the end user in the case of any of the following products or parts of products:

- Electric motors and associated electrical equipment
- Electronic controls
- Hydraulic pumps, valves and actuators
- Weather seals
- Products used in "Grand Prix" racing applications
- Products used in commercial and charter applications
- Anchor rodes

### C LIABILITY

- i** Lewmar's liability under this warranty shall be to the exclusion of all other warranties or liabilities (to the extent permitted by law). In particular (but without limitation):
  - a.** Lewmar shall not be liable for:
    - Any loss of anticipated turnover or profit or indirect, consequential or economic loss;
    - Damages, costs or expenses payable to any third party;
    - Any damage to yachts or equipment;
    - Death or personal Injury (unless caused by Lewmar's negligence).

Some states and countries do not allow the exclusion or limitation of incidental or consequential damages, so the above limitation or exclusion may not apply to you.

- b.** Lewmar grants no other warranties regarding the fitness for purpose, use, nature or satisfactory quality of the products.
- ii** Where applicable law does not permit a statutory or implied warranty to be excluded, then such warranty, if permitted by that state or country's law, shall be limited to

a period of one year from the date of purchase by the end user. Some states and countries do not allow limitations on how long an implied warranty lasts, so this limitation may not apply to you.

### D PROCEDURE

Notice of a claim for service under this warranty shall be made promptly and in writing by the end user to the Lewmar outlet which supplied the product or to Lewmar Limited at Southmoor Lane, Havant, Hampshire PO9 1JJ, England.

### E SEVERANCE CLAUSE

If any clause of this warranty is held by any court or other competent authority to be invalid or unenforceable in whole or in part, the validity of the remaining clauses of this warranty and the remainder of the clause in question shall not be affected.

### F OTHER RIGHTS

This warranty gives you specific legal rights, and you may also have other legal rights, which vary, from state to state and country to country.

In the case of European States a Consumer customer (as defined nationally) has legal rights under the applicable national law governing the sale of Consumer Goods; this Warranty does not affect those rights.

### G LAW

This warranty shall be governed by and read in accordance with the laws of England or the state or country in which the first end user is domiciled at the time of purchase of the product.

### H DISPUTES

Any dispute arising under this warranty may, at the option of the end-user, be referred to alternative dispute resolution under the rules of the British Marine Federation or to the Courts of the State whose law shall govern the warranty or to the Courts of England and Wales.

The British Marine Federation may be contacted at

Marine House, Thorpe Lea Road, Egham, England, TW20 8BF

# LEWMAR®

## UK Headquarters & International Distribution

Southmoor Lane  
Havant  
Hampshire  
PO9 1JJ, UK

Tel: +44 (0)23 9247 1841  
Email: [info@lewmar.com](mailto:info@lewmar.com)  
Tech Support Email: [techsupport@lewmar.com](mailto:techsupport@lewmar.com)

[www.lewmar.com](http://www.lewmar.com)



## USA

351 New Whitfield Street  
Guilford, CT  
06437  
USA

Tel: +1 203 458 6200  
Email: [info@lewmar.com](mailto:info@lewmar.com)  
Tech Support Email: [ustechsupport@lewmar.com](mailto:ustechsupport@lewmar.com)

